

0000000000000000™  
**COLDSTORE**  
SURVEILLANCE STORAGE SYSTEM



APPLICATION | COLDSTORE is used for long retention storage by Power Companies

The world's most reliable surveillance storage system designed to perfectly preserve the veracity of your IP video

COLDSTORE's sequential recording system SFS™ writes to hard disk in a revolutionary way, offers high reliability and extremely low total cost of ownership.

- | Network Attached Storage System with LAID & SFS for high disk reliability
- | Compatible with Wisenet WAVE VMS servers
- | 210TB capacity in 3U using only 60W
- | No data loss on disk failure and no rebuild required
- | Automatic disk management
- | Compatible with almost all types of SATA disk drive
- | Dual hot-swap PSU and dual GigE network ports



# COLDSTORE 3U is a unique sequential surveillance storage array designed from the ground up for surveillance

COLDSTORE 3U is ideal for projects requiring affordable high storage capacity, extended disk lifetimes, long file-retention and simple system management.



COLDSTORE 3U Front Panel includes LCD system info and disk status LEDs

## Reliability assured

Our Linear Array of Idle Disks (L.A.I.D™) technology combined with unique Sequential disk Filing System (S.F.S™) produces a powerfully simple system which can provide generous storage capacity at low cost. Whilst simple in concept, this delivers a highly reliable storage system which dramatically extends disk lifetime even when using the lowest cost disks available.

## Low power, low cost

COLDSTORE 3U uses only one tenth of the power of comparable systems, is resilient to disk failure, requires no disk rebuild process and reduces running costs.

It provides an easy way to instantly extract and transport critical evidential video data.

## Extended Disk Lifetimes

Disks are used sequentially, with all of the disks not in use being switched off, saving power and thus greatly reducing temperature, vibration and wear – the three primary disk killers.

The system uses a unique mirrored overlapping-pair writing pattern to provide full data redundancy during the critical writing process. This delivers the redundancy of RAID1 on write, but unlike RAID1, does not require double the number of disks.

Within the disk, the sequential disk filing system eliminates vibration from the read/write head and lowers the operating temperature. Within the array, the use of sequential overlapping mirrored writing pairs requires only two active disks at any one time

with the others switched off. This greatly reduces wear and further reduces array vibration and operating temperature. Thus every disk is off, on average, for 87% of the time. Disks automatically switch on for playback, but typically playback from non-writing disks is infrequent and hardly affects the average duty cycle.

## Purpose-Designed System

COLDSTORE 3U is built around a custom designed main-board system with low-power CPU and directly connected SATA backplane.

Even a fully populated 210TB array will only use 60 watts. The low power system extends the electronic component lifetime, which, combined with the extended disk lifetimes results in a very low overall total cost of ownership.

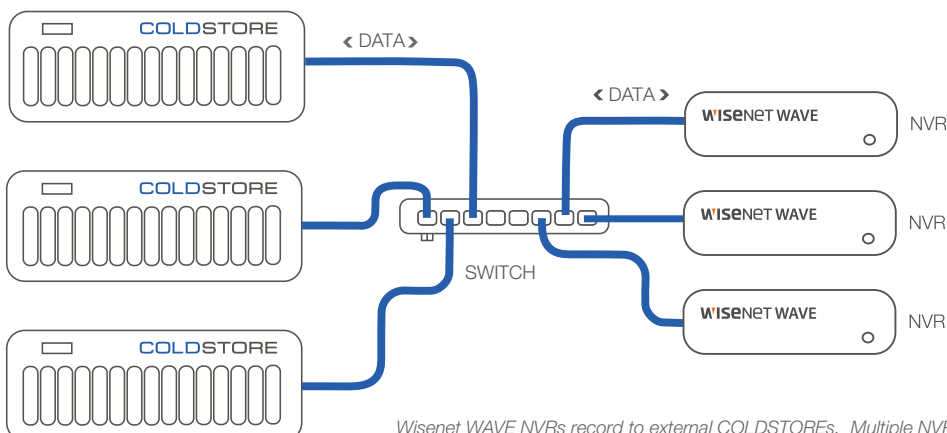

Wisenet WAVE NVRs record to external COLDSTOREs. Multiple NVRs can write to a single COLDSTORE. A single NVR can be configured to write to two or more COLDSTOREs (for long retention time applications) with automatic load-balancing. A software plug-in for the Wisenet WAVE servers enables full COLDSTORE compatibility.

## Low power and high capacity make COLDSTORE 3U an ideal system for long retention of 30 to 180 days or more

Removable drives containing specific time-spans enables rapid extraction of critical evidential data for law enforcement purposes.

### Configuration and Management

COLDSTORE 3U is simple to configure, manage and monitor through Veracity's universal device configuration tool, SITESCAPE. This Windows application allows automatic device discovery, configuration of settings, analysis of disks and a basic level of diagnostics.

### Simple Disk Management

COLDSTORE can use almost any make, model and capacity of 3.5" SATA disk drives including any mix of drives. Disks may be added "on the fly" and will automatically be incorporated into the array. The physical location of specific time spans can be identified through SITESCAPE and disks may be extracted at any time. The disk status LEDs above each disk slot indicate writing, selection, fault and removal

readiness. These simple features, along with the user-friendliness of SITESCAPE, allow COLDSTORE and the disks to be easily managed by system integrators and end-users alike. In addition to the mirrored overlapping-pair mode, COLDSTORE can also operate in full mirrored pair mode if desired.

### Integration

Veracity and Hanwha Techwin have partnered together to ensure complete compatibility between the Wisenet WAVE VMS and COLDSTORE video storage. Veracity provides a free-of-charge software plug-in for the Wisenet WAVE server. The combination of Wisenet WAVE and COLDSTORE results in a high-performance video recording and management system with a large

maximum capacity and very low total cost of ownership, due to the extreme reliability of hard disks when used in COLDSTORE and the very low power consumption of the system.

### Scaled Systems

COLDSTORE storage systems scale up to very large capacities for high numbers of cameras and/or long retention times simply by adding additional arrays onto the network. No complicated management software is required.

Each Wisenet WAVE server can write to multiple COLDSTOREs if required, with automatic load-balancing between the storage units. This provides automatic storage-level fail-over if required.



Rear view (above) showing dual Gig-E ports, alarm/relay connections and the dual hot-swap PSU option. Note that the cooling fans are software controlled and are normally switched off.



COLDSTORE Disk Capacity is subject to change. Please check our website for the most up to date disk capacities.  
[www.veracityglobal.com](http://www.veracityglobal.com)

## TECHNICAL SPECIFICATION

## COLDSTORE™

<b>GENERAL</b>	
Storage array type	Networked attached sequential array running L.A.I.D.™ with S.F.S.™ disk filing system
Drive bays	15" x 3.5" (lockable drive trays included)
Interface	Dual Gigabit Ethernet
Data throughput	400Mbit/sec (unlimited scalability with multiple COLDSTORE units)
<b>SYSTEM</b>	
O.S.	Embedded Linux on solid state memory
Time synchronization	Via NTP (recommended)
System integration	Wisenet WAVE VMS (all Windows versions, via VMS server software plug-in)
Configuration	Over LAN via Veracity's SITESCAPE application
Management	By front panel, or over LAN via Veracity's SITESCAPE application
<b>CAPACITY</b>	
Disk capacity and type	SATA disks of any capacity and most makes and models are compatible Check our website for up to date disk capacities <a href="http://www.veracityglobal.com">www.veracityglobal.com</a>
Array capacity	Maximum array capacity is currently - 210TB (with current max available 14TB disks) Effective capacity - Mirrored Overlapping - 196TB Effective capacity - Mirrored Pair - 98TB
<b>ALARMS</b>	
Alarm relays	4 software configurable e.g. disk fail, disk inserted, disk extracted, etc.
Alarm inputs	4 software configurable e.g. UPS active, power down, etc.
<b>POWER</b>	
Power supply type	Dual hot-swap PSU
Power supply rating	110-240V AC Input (Auto sensing)
Power consumption	60 watts typical maximum (PSU rated at 320W)
<b>PHYSICAL/ENVIRONMENTAL</b>	
Dimensions	19" rack width, 3U high, 483mm deep (W 440mm x D 483mm x H 131mm)
Weight	15.6kg (34.4lbs)
Operating temperature	5°C to 50°C (41°F to 122°F)
Relative humidity	Up to 85%, non-condensing
Compliance	CE, FCC, RoHS
<b>PRODUCT CODES</b>	
VER-CSTORE15	COLDSTORE 15-bay 3U unit, configured for Wisenet WAVE, USA power cables
VER-CSTORERAIL	Rack mount rails for supporting COLDSTORE chassis in 19" racks
VER-CSTORECRDL	HDD Cradle



veracity

America Sales |  
Veracity USA Inc. 17000 Preston Road  
Suite 120  
Dallas  
TX 75248  
USA  
Tel: 1-800-679-1590

[www.veracityglobal.com](http://www.veracityglobal.com)  
[sales@veracityglobal.com](mailto:sales@veracityglobal.com)

See [www.veracityglobal.com](http://www.veracityglobal.com) website  
for country and region specific contacts.