

Data sheet | Item number: 852-201/107-002

SFP module 2: 1310nm; 100Base-FX Multi-Mode LC; 2 km; silver-colored

www.wago.com/852-201/107-002



RoHS Compliant

BOMcheck.net

Color:

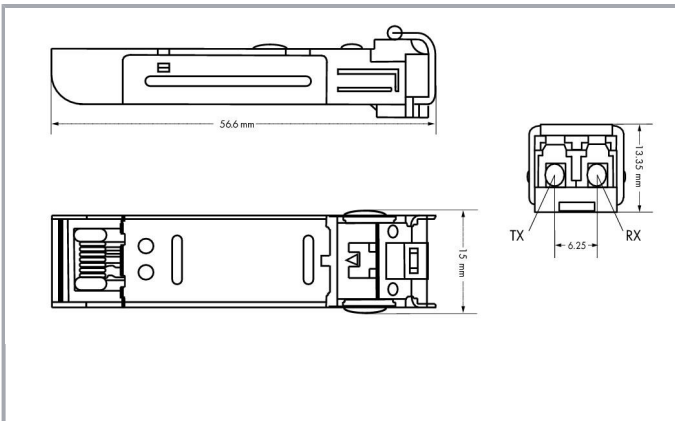
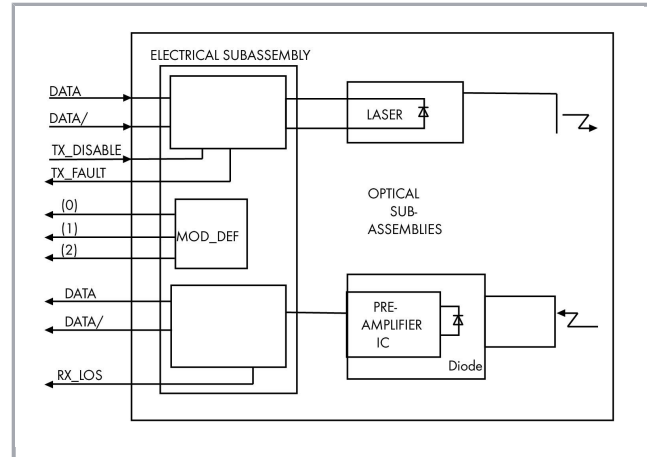

Item description

Features:

- Duplex LC optical connector
- Small Form-Factor Pluggable (SFP) industry-standard design

Subject to changes. Please also observe the further product documentation!

WAGO Kontakttechnik GmbH & Co. KG
Hansastr. 27
32423 Minden
Phone: +49571 887-0 | Fax: +49571 887-169
Email: info.de@wago.com | Web: www.wago.com

Do you have any questions about our products?
We are always happy to take your call at +49 (571) 887-44222.



- Compliant with Fast ETHERNET standard
- Differential LVPECL inputs and outputs
- Power supply: 3.3 V
- TTL signal detect indicator
- Hot-pluggable capability

Data

Technical Data

Optical fiber type	Multi-mode
--------------------	------------

Connection data

Connection technology: communication/fieldbus	1 x SFP; LC fiber-optic connector
Connection requirement, permissible cable length	2,000 m
Connection requirement (permissible cable type)	Multi-mode fiber 62.5/125 µm, 50/125 µm; Wavelength: 1310 nm

Geometrical Data

Width	13,4 mm / 0.528 inch
Height	13,3 mm / 0.524 inch
Depth	56,6 mm / 2.228 inch

Mechanical data

Weight	24.3 g
Color	silver-colored

Environmental Requirements

Surrounding air temperature (operation)	-40 ... 70 °C
Surrounding air temperature (storage)	-40 ... 80 °C

Commercial data

Packaging type	BOX
Country of origin	TW
GTIN	4045454635404
Customs tariff number	85176200000

Counterpart

Subject to changes. Please also observe the further product documentation!

WAGO Kontakttechnik GmbH & Co. KG
Hansastr. 27
32423 Minden
Phone: +49571 887-0 | Fax: +49571 887-169
Email: info.de@wago.com | Web: www.wago.com

Do you have any questions about our products?
We are always happy to take your call at +49 (571) 887-44222.



Downloads

Documentation

Bid Text

852-201/107-002 doc - Datei	Mar 9, 2018	doc 26.1 kB	Download
--------------------------------	-------------	----------------	----------

852-201/107-002 GAEB X81 - Datei	Feb 19, 2019	xml 3.9 kB	Download
-------------------------------------	--------------	---------------	----------

System Description

Industrial Switches – General Product Information		pdf 2.0 MB	Download
---	--	---------------	----------

CAD/CAE-Data

CAE data

EPLAN Data Portal 852-201/107-002		URL	Download
-----------------------------------	--	-----	----------

WSCAD Universe 852-201/107-002		URL	Download
--------------------------------	--	-----	----------

Installation Notes

Subject to changes. Please also observe the further product documentation!