

Data sheet | Item number: 216-244

Ferrule; Sleeve for 1.5 mm² / AWG 16; insulated; electro-tin plated;
electrolytic copper; gastight crimped; acc. to DIN 46228, Part 4/09.90; black

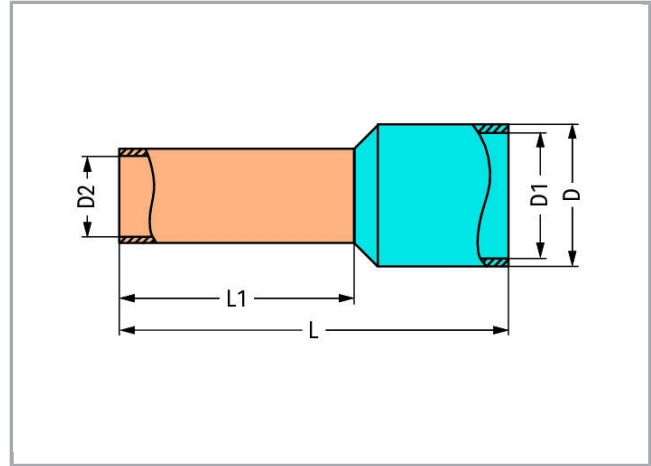

www.wago.com/216-244



Subject to changes. Please also observe the further product documentation!

WAGO Kontakttechnik GmbH & Co. KG
Hansastr. 27
32423 Minden
Phone: +49571 887-0 | Fax: +49571 887-169
Email: info.de@wago.com | Web: www.wago.com

Do you have any questions about our products?
We are always happy to take your call at +49 (571) 887-44222.



Subject to changes. Please also observe the further product documentation!

RoHS 
Compliant

BOMcheck.net

Color: 

Data

Technical Data

Main product function	Ferrule
Sleeve cross-section (AWG)	16 AWG
Sleeve for	1.5 mm ²

Connection data

Strip length	12 mm / 0.47 inch
--------------	-------------------

Geometrical Data

Length	16 mm
Length	16 mm
Length 1	10 mm
Diameter	4 mm
Diameter	4 mm
Diameter 1	3.5 mm
Diameter 2	1.7 mm

Material Data

Color	black
Fire load	0.002 MJ
Weight	0.1 g

Commercial data

Product Group	2 (Terminal Block Accessories)
Packaging type	BOX
Country of origin	DE
GTIN	4044918016346
Customs tariff number	85369010000

Subject to changes. Please also observe the further product documentation!

WAGO Kontakttechnik GmbH & Co. KG
Hansastr. 27
32423 Minden
Phone: +49571 887-0 | Fax: +49571 887-169
Email: info.de@wago.com | Web: www.wago.com

Do you have any questions about our products?
We are always happy to take your call at +49 (571) 887-44222.

Counterpart

Downloads

Documentation

Bid Text

216-244 GAEB X81 - Datei	Feb 19, 2019	xml 2.9 kB	Download
216-244 doc - Datei	Sep 11, 2017	doc 24.1 kB	Download

Installation Notes

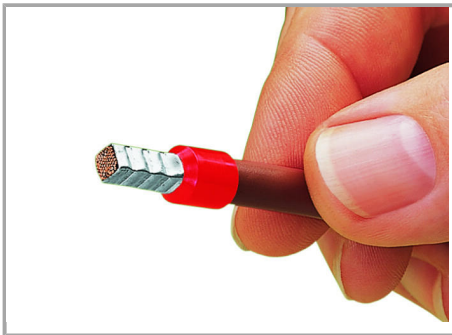

A perfect gas-tight crimp – both electrically and mechanically reliable

Subject to changes. Please also observe the further product documentation!