

2

1

THIS COPY IS PROVIDED ON A RESTRICTED BASIS AND IS NOT TO BE USED IN ANY WAY DETRIMENTAL TO THE INTERESTS OF PANDUIT CORP.

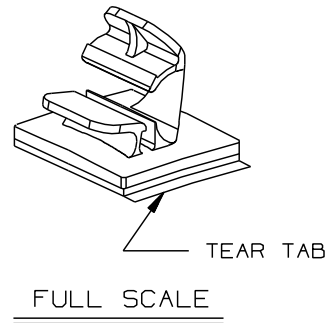
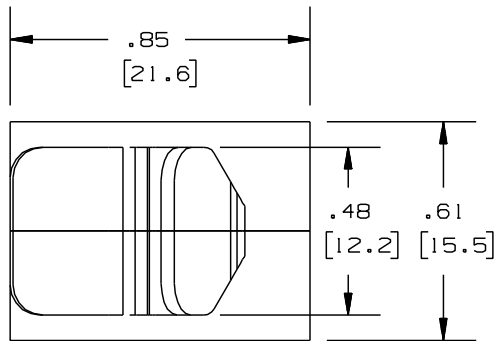

PANDUIT PART NUMBER*	MAXIMUM CABLE DIA. in. (mm)	WEIGHT lbs. (g)/100pcs
LWC19-A	0.19 (4.8)	0.29 (130)

NOTES:

- *1) SEE <http://www.panduit.com> FOR PART NUMBER SUFFIX DESIGNATION, FOR PACKAGE SIZE.
- 2) MOUNT IS DESIGNED TO SUPPORT 0.25 lbs (113.4g) MAX WEIGHT ON A CLEAN DRY SMOOTH SURFACE.

- TO APPLY LATCHING WIRE CLIP:
1. REMOVE PROTECTIVE LINER
 2. PLACE IN DESIRED LOCATION
 3. APPLY PRESSURE TO TOP OF LATCHING WIRE CLIP

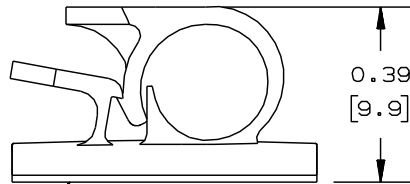

ADHESIVE BACKING: PRESSURE SENSITIVE FOAM 0.04 (1.0) THICK WITH PROTECTIVE LINER TO EXTEND BEYOND EDGE FORMING A TEAR TAB.

NO WARRANTY, EXPRESSED OR IMPLIED, IS MADE BY PANDUIT WITH RESPECT TO ADHESIVE BOND PERFORMANCE, AMONG OTHER THINGS, THE CONDITIONS UNDER WHICH THESE MOUNTS MAY BE APPLIED, AND/OR THE SURFACE TO WHICH THEY MAY BE APPLIED, ARE BEYOND PANDUIT'S CONTROL.

DIMENSIONS IN BRACKETS ARE METRIC (mm)

REV	DATE	BY	CHK	APR	DESCRIPTION	ECN
3	8/05/13	BWG	MPH	RTF I	REVISED MAX. CABLE DIA. SEE ECN FOR DETAILS.	GB0239EH/03
3	8/05/13	BWG	MPH	RTF I	AND REVISED TITLE BORDER.	GB0239EH/03

TITLE LWC19-A, LATCHING WIRE CLIP		CUSTOMER DRAWING	
ITEM REVISION NAME 10B015EQ/02		PANDUIT	
DATASET FILE NAME 10B015EQ_DC/02 - GB0239EH_REV03			
UNLESS OTHERWISE SPECIFIED, DIMENSIONAL TOLERANCES ARE: IN (mm) .x ± 0.05 (1.3) .xxx ± 0.010 (0.25) .xx ± 0.02 (0.5) ANGLES ± 5°		MATERIAL: NYLON 6/6	
DRAWN BY AJV		DRAWING NUMBER: GB0239EH	
DATE 9-20-96	CHK	SCALE 2X	SIZE A
THIRD ANGLE PROJECTION		SHT 1 OF 1	

2

1

D101000A/16