

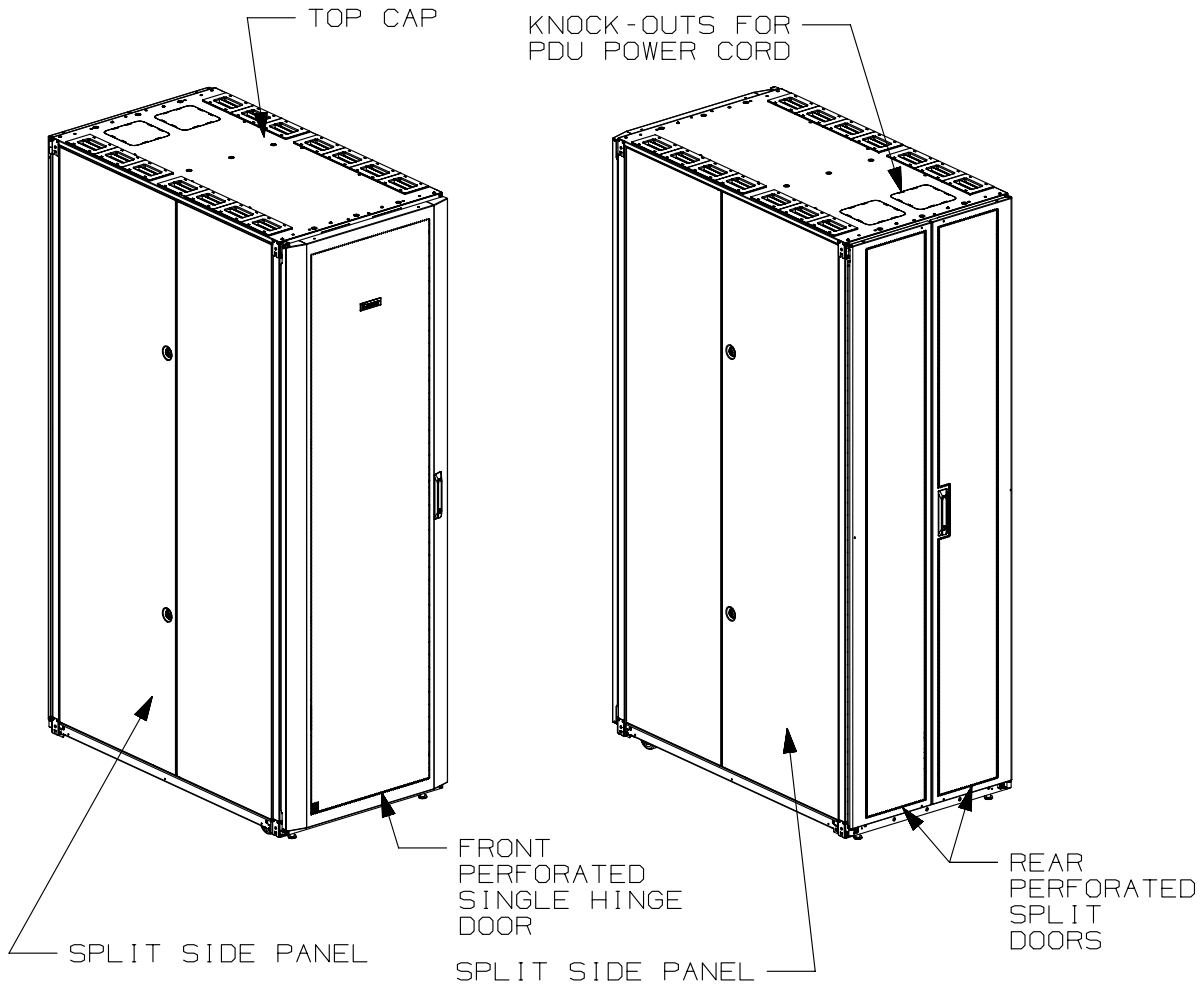

THIS COPY IS PROVIDED ON A RESTRICTED BASIS AND IS NOT TO BE USED IN ANY WAY DETRIMENTAL TO THE INTERESTS OF PANDUIT CORP.



1. VISIT OUR ON-LINE CATALOG AT [WWW.PANDUIT.COM](http://WWW.PANDUIT.COM) FOR A LIST OF CURRENT PARTS APPLICABLE FOR USE WITH THIS PRODUCT.
2. PRIMARY DIMENSIONS ARE IN MILLIMETERS.
3. FACTORY SETTINGS:
  - FRONT FACE OF FRONT E-RAILS ARE 167mm [6.57in] FROM FRONT FACE OF FRAME.
  - FRONT FACE OF REAR E-RAILS ARE 412.75mm [16.25in] FROM FRONT FACE OF FRONT E-RAILS.
4. ADJUSTMENTS:
  - RAIL ADJUSTMENT MEASUREMENTS ARE TAKEN FROM THE FRONT FACE OF EACH EQUIPMENT RAIL.
  - FRONT E-RAILS CAN ADJUST AS FAR FORWARD AS 167mm [6.57in] FROM FRONT FACE OF FRAME.
  - WHEN FRONT E-RAILS ARE 167mm [6.57in] FROM FRONT FACE OF FRAME, REAR E-RAILS CAN ADJUST FROM 62mm [2.44in] TO 423mm [16.65in] AND FROM 473mm [18.62in] TO 975mm [38.38in].
5. CAN BE USED WITH ANY 19" EIA STANDARD COMPONENT IN ADDITION TO ALL PANDUIT HORIZONTAL CABLE MANAGEMENT AND PATCH PANEL PRODUCTS.
6. EIA UNIVERSAL STANDARD HOLE PROGRESSION ON EQUIPMENT RAILS  
 15.88mm [.625in], 15.88mm [.625in], 12.70mm [.5in], 15.88mm [.625in], 15.88mm [.625in], 12.70mm [.5in]...ETC.
7. PARTS SUPPLIED:
  - BASE CABINET
  - FRONT PERFORATED SINGLE HINGE DOOR (SEE CHART ON SHEET 2)
  - REAR PERFORATED SPLIT DOOR (SEE CHART ON SHEET 2)
  - SPLIT SIDE PANELS (SEE CHART ON SHEET 2)
  - CAGE NUT UTILITY STYLE EQUIPMENT RAILS FRONT AND REAR (SEE CHART ON SHEET 2)
  - CASTERS (SEE CHART ON SHEET 2)
  - CABLE MANAGEMENT FINGERS (SEE CHART ON SHEET 2)
  - CABINET HARDWARE KIT
  - INSTRUCTION SHEET
8. RACK UNIT SPACING NUMERALS ARE CLEARLY PRINTED ON EQUIPMENT MOUNTING RAILS.
9. FULLY BONDED STRUCTURE WHEN ASSEMBLED PER INSTRUCTIONS.
10. STATIC LOAD RATING. 1360 Kg (3000 LBS)
11. ROLLING LOAD RATING. 1133 Kg (2500 LBS)
12. SINGLE POINT GROUND LOCATIONS AT TOP AND BOTTOM OF CABINET.
13. ALL CABINET RAILS ARE INSTALLED NUMBERS UP.

REV	DATE	BY	CHK	APR	DESCRIPTION	ECN
01A	12-01-14	MDCA	ADP	TCN	FLOOR MOUNT DIMENSIONS UPDATED	V09000BX
00A	6-3-13	TWV	JDW	PBD	RELEASED TO PRODUCTION	12V352BU-DC

TITLE		NET-ACCESS S TYPE UTILITY CABINET 700mm WIDE X 1200mm DEEP FAMILY		
		CUSTOMER DRAWING		
ITEM REVISION NAME		12V352BU/01.PRT		
DATASET FILE NAME		12V352BU_DC/01A.PRT		
				
		MATERIAL: N/A		
		DRAWING NUMBER: 12V352BU-DC		
DRAWN BY	DATE	CHK	SCALE	SIZE
TWV	6-3-13	JDW	NONE	A

THIS COPY IS PROVIDED ON A RESTRICTED BASIS AND IS NOT TO BE USED IN ANY WAY DETRIMENTAL TO THE INTERESTS OF PANDUIT CORP.

PART NO.	DESCRIPTION	SINGLE HINGE FRONT DOOR	SPLIT REAR DOOR	SPLIT SIDE PANEL	ADJUSTABLE FRONT UTILITY E-RAILS	REAR CAGE NUT FINGER MGMT E-RAILS	STANDARD PDU BRACKETS	CASTERS	CABLE MGMT FINGERS	CABINET WEIGHT FULLY UNPACKAGED	CABINET WEIGHT SHIPPING WEIGHT
S7222*A	NET-ACCESS S-TYPE CABINET 700mm X 42RU X 1200mm DEEP	01	01	02	02	02	00	04	01	139 Kg/EACH 307 LBS/EACH	160 Kg/EACH 352 LBS/EACH
S7522*A	NET-ACCESS S-TYPE CABINET 700mm X 45RU X 1200mm DEEP	01	01	02	02	02	00	04	01	146 Kg/EACH 322 LBS/EACH	166 Kg/EACH 367 LBS/EACH
S7822*A	NET-ACCESS S-TYPE CABINET 700mm X 48RU X 1200mm DEEP	01	01	02	02	02	00	04	01	153 Kg/EACH 337 LBS/EACH	173 Kg/EACH 382 LBS/EACH
S7229*A	NET-ACCESS S-TYPE CABINET 700mm X 42RU X 1200mm DEEP	01	01	00	02	02	00	04	01	99 Kg/EACH 219 LBS/EACH	120 Kg/EACH 264 LBS/EACH
S7529*A	NET-ACCESS S-TYPE CABINET 700mm X 45RU X 1200mm DEEP	01	01	00	02	02	00	04	01	106 Kg/EACH 235 LBS/EACH	127 Kg/EACH 280 LBS/EACH
S7829*A	NET-ACCESS S-TYPE CABINET 700mm X 48RU X 1200mm DEEP	01	01	00	02	02	00	04	01	113 Kg/EACH 250 LBS/EACH	134 Kg/EACH 295 LBS/EACH

\* DENOTES COLOR  
 "B" = BLACK  
 "W" = WHITE

01A	12-01-14	MDCA	ADP	TCN	SEE SHEET 1 OF 5 FOR REVISIONS	V09000BX
00A	6-3-13	TWV	JDW	PBD	SEE SHEET 1 OF 5 FOR REVISIONS	12V352BU-DC
REV	DATE	BY	CHK	APR	DESCRIPTION	ECN

TITLE		NET-ACCESS S TYPE UTILITY CABINET 700mm WIDE X 1200mm DEEP FAMILY	
		CUSTOMER DRAWING	
ITEM REVISION NAME		12V352BU/01.PRT	
DATASET FILE NAME		12V352BU_DC/01A.PRT	
		MATERIAL:	
		N/A	
		DRAWING NUMBER:	
		12V352BU-DC	
DRAWN BY		DATE	
TWV		6-3-13	
CHK		SCALE	
JDW		NONE	
SHT 2 OF 5		SIZE	
		A	

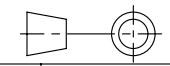

THIRD ANGLE PROJECTION

THIS COPY IS PROVIDED ON A RESTRICTED BASIS AND IS NOT TO BE USED IN ANY WAY DETRIMENTAL TO THE INTERESTS OF PANDUIT CORP.

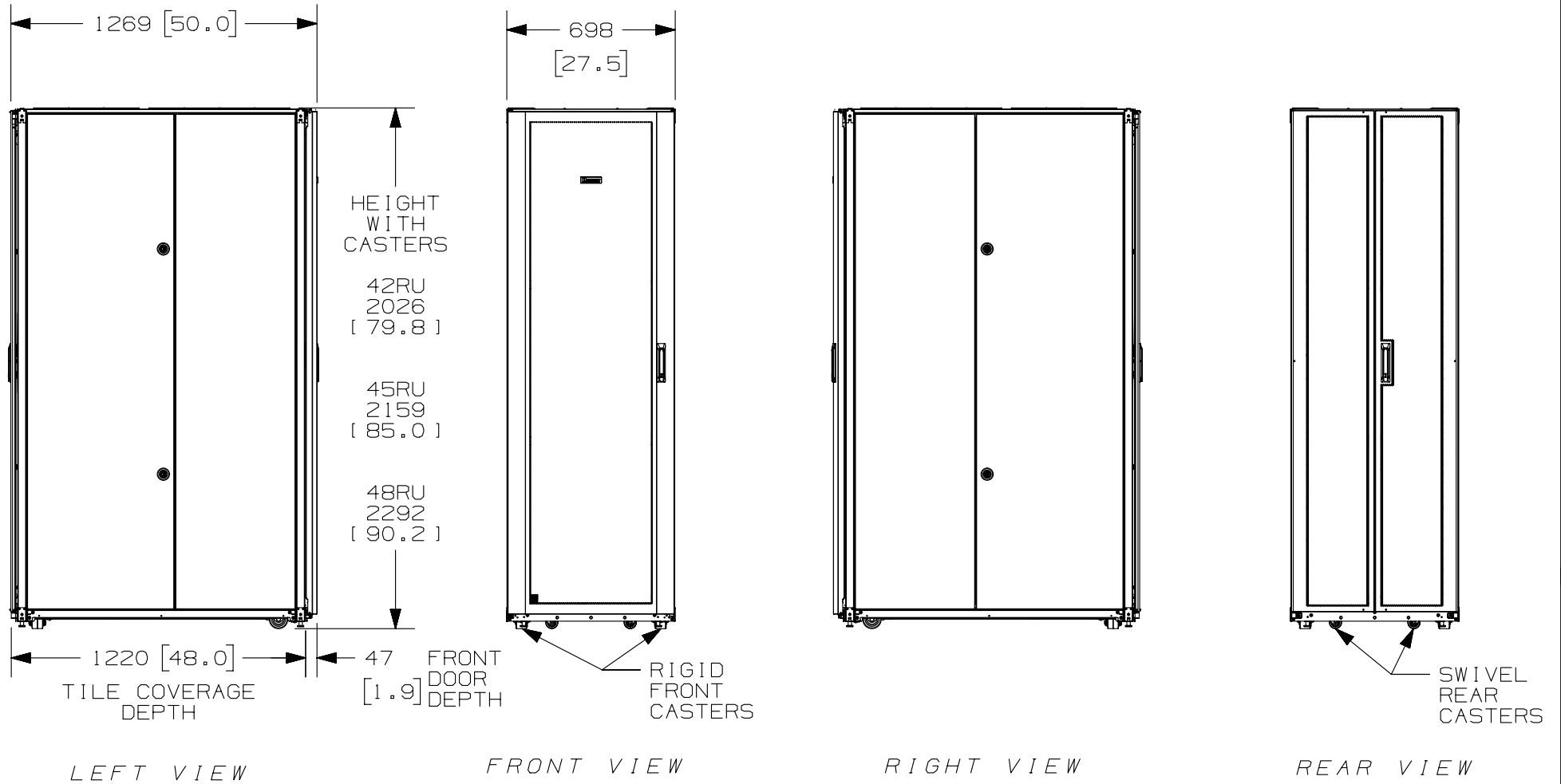

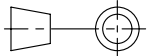
						TITLE		NET-ACCESS S TYPE UTILITY CABINET 700mm WIDE X 1200mm DEEP FAMILY				
								CUSTOMER DRAWING				
						ITEM REVISION NAME		<b>PANDUIT</b>				
						12V352BU/01.PRT						
						DATASET FILE NAME		MATERIAL:				
						12V352BU_DC/01A.PRT		N/A				
01A	12-01-14	MDCA	ADP	TCN	SEE SHEET 1 OF 5 FOR REVISIONS	V09000BX	 THIRD ANGLE PROJECTION DRAWING NUMBER: 12V352BU-DC					
00A	6-3-13	TWV	JDW	PBD	SEE SHEET 1 OF 5 FOR REVISIONS	12V352BU-DC						
REV	DATE	BY	CHK	APR	DESCRIPTION	ECN	DRAWN BY	DATE	CHK	SCALE	SHT 3 OF 5	SIZE
							TWV	6-3-13	JDW	NONE		A

THIS COPY IS PROVIDED ON A RESTRICTED BASIS AND IS NOT TO BE USED IN ANY WAY DETRIMENTAL TO THE INTERESTS OF PANDUIT CORP.

RACK UNITS ARE  
NUMBERED AND  
INDEXED FOR  
IDENTIFICATION

(2) UTILITY  
EQUIPMENT  
RAILS

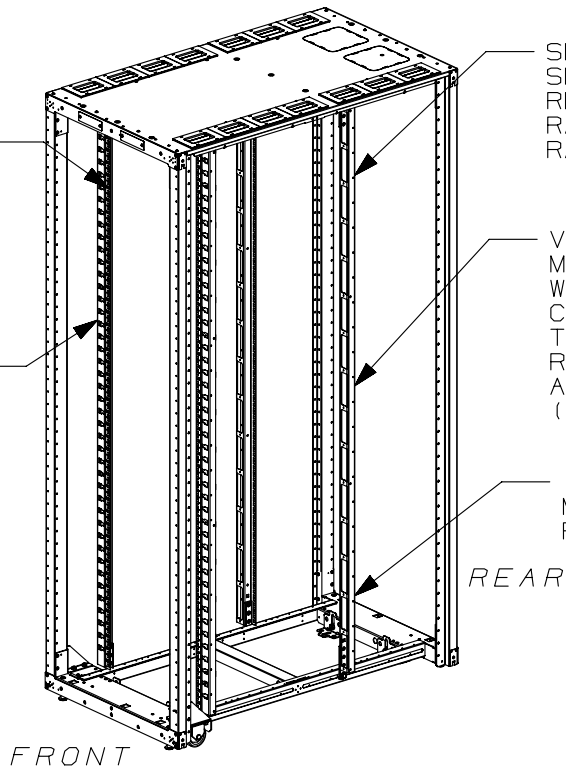

(9) LOCATIONS  
TAPPED FOR M10  
THREADED ROD

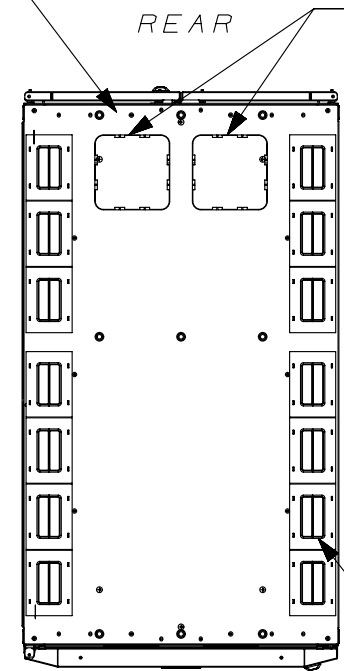

FRONT  
TOP VIEW

FRONT DOOR, REAR DOOR,  
AND SIDE PANELS NOT SHOWN

REV	DATE	BY	CHK	APR	DESCRIPTION	ECN
01A	12-01-14	MDCA	ADP	TCN	SEE SHEET 1 OF 5 FOR REVISIONS	V09000BX
00A	6-3-13	TWV	JDW	PBD	SEE SHEET 1 OF 5 FOR REVISIONS	12V352BU-DC

TITLE		NET-ACCESS S TYPE UTILITY CABINET 700mm WIDE X 1200mm DEEP FAMILY	
		CUSTOMER DRAWING	
ITEM REVISION NAME		12V352BU/01.PRT	
DATASET FILE NAME		12V352BU_DC/01A.PRT	
MATERIAL:		N/A	
DRAWING NUMBER:		12V352BU-DC	
DRAWN BY	DATE	CHK	SCALE
TWV	6-3-13	JDW	NONE
THIRD ANGLE PROJECTION		SHT 4 OF 5	
SIZE		A	

THIS COPY IS PROVIDED ON A RESTRICTED BASIS AND IS NOT TO BE USED IN ANY WAY DETRIMENTAL TO THE INTERESTS OF PANDUIT CORP.

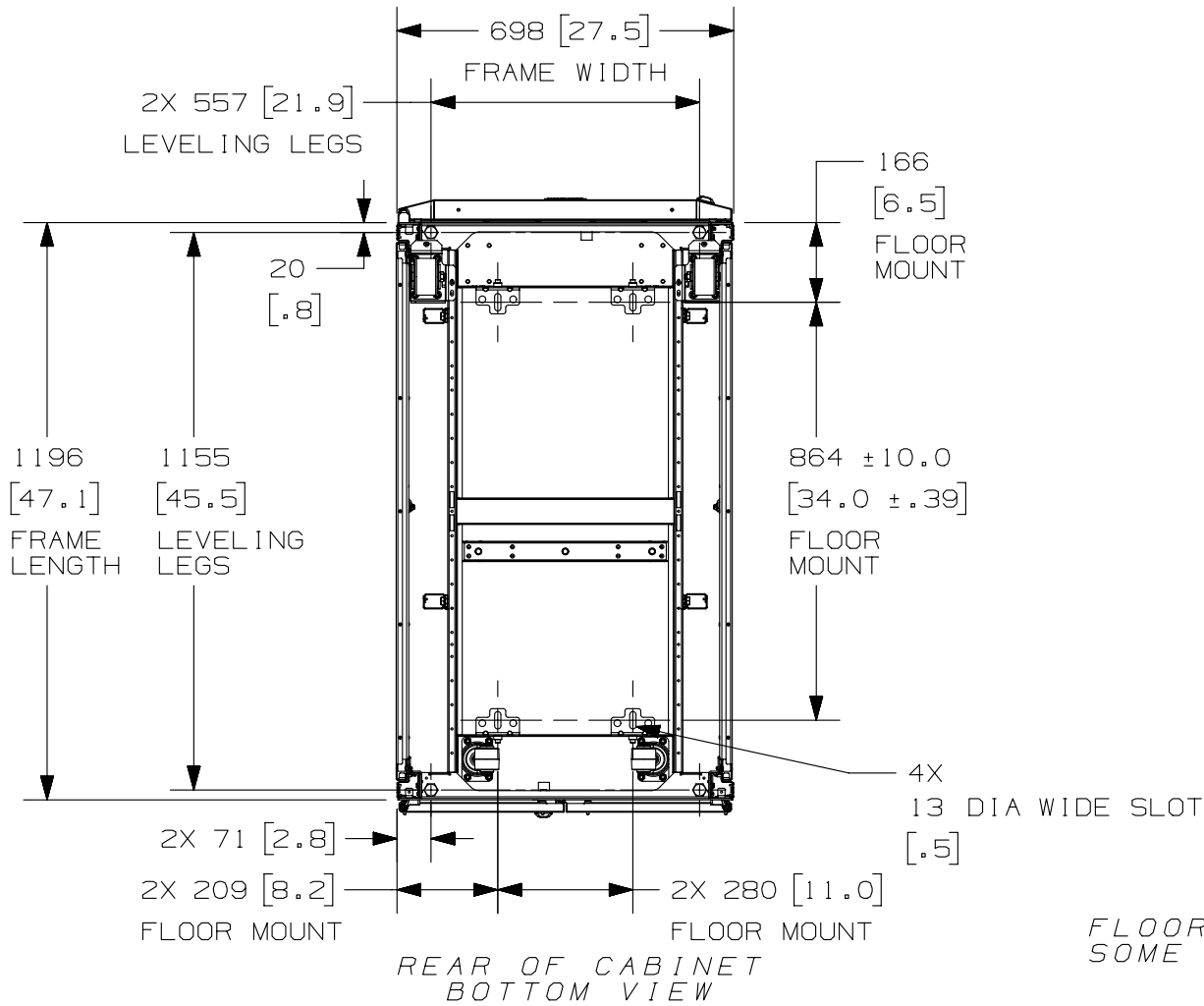

FLOOR MOUNTING HOLE LOCATIONS -  
SOME PARTS REMOVED FOR CLARITY

REV	DATE	BY	CHK	APR	DESCRIPTION	ECN
01A	12-01-14	MDCA	ADP	TCN	SEE SHEET 1 OF 5 FOR REVISIONS	V09000BX
00A	6-3-13	TWV	JDW	PBD	SEE SHEET 1 OF 5 FOR REVISIONS	12V352BU-DC

TITLE		NET-ACCESS S TYPE UTILITY CABINET 700mm WIDE X 1200mm DEEP FAMILY		
		CUSTOMER DRAWING		
ITEM REVISION NAME		12V352BU/01.PRT		
DATASET FILE NAME		12V352BU_DC/01A.PRT		
		MATERIAL:  N/A		
		DRAWING NUMBER: 12V352BU-DC		
DRAWN BY	DATE	CHK	SCALE	SIZE
TWV	6-3-13	JDW	NONE	A

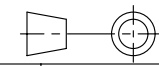

THIRD ANGLE  
PROJECTION