

TX6A™ Shielded Field Term RJ45 Plug

PANDUIT™

SPECIFICATION SHEET

specifications

The TX6A™ Shielded Field Term RJ45 Plug is a simple-to-attach plug for field termination of 4-pair shielded twisted pair cable. Providing Category 6A performance the TX6A™ plug is also compatible with Category 6 and 5e shielded systems. The two-piece straight TX6A™ shielded plug terminates 4-pair, 22 - 26 AWG, 100 ohm shielded twisted pair cable and uses proven TG-style forward motion termination technology to optimize performance by maintaining cable pair geometry while eliminating conductor untwist.



applications

The simple-to-attach TX6A™ Shielded Field Term RJ45 Plug is ideal for connecting network-powered devices to shielded networks using MPTL links or anywhere field attachment of a plug to shielded cable is desired. Typical applications include:

- Wireless access points (WAPs)
- Power over Ethernet (PoE) LED lighting
- IP security cameras and motion sensors
- Building access control points
- Network-attached Audio/Video equipment
- Other PoE or HDBASE-T powered network devices

technical information

Category 6A/Class E_A performance:	Exceeds ANSI/TIA 568.2-D Category 6A and ISO 11801 Class E _A Channel performance requirements with up to two field term plugs in channel. Meets or exceeds TIA Modular Plug Terminated Link (MPTL) requirements with up to two field term plugs in link
Cable compatibility:	Compatible with 4-pair, 22–26 AWG solid or stranded shielded twisted pair cable with conductor insulation diameters of 0.039 in. to 0.063 in. (1.0mm to 1.6mm) and overall cable O.D. 0.230 in. to 0.354 in. (5.8mm to 9.0mm)
FCC and ANSI compliance:	Meets ANSI/TIA-1096-A (formerly FCC Part 68)
IEC compliance:	IEC 60603-7, IEC 60529 (IP 20)
RoHS compliance:	Compliant
PoE & PoH compliance:	Supports IEEE 802.3af / 802.3at (PoE/PoE+) and 802.3bt type 3 and type 4 (PoE++) applications. Supports Power over HDBaseT up to 100 watts.
Plug mating cycles:	Rated to 2500 mating cycles
UL rated:	UL 1863 (Use as communications circuit accessory) UL 2043 (Suitable for use in air-handling spaces)
Operating temperature:	-40°C to +85°C (-40°F to +185°F)
Storage temperature:	-40°C to +85°C (-40°F to +185°F)

key features and benefits

Simple two-piece assembly	Field friendly, easier to handle during field installation, saving time and reducing termination error
Slim plug profile	Easily fits in tight port spaces or high-density port configurations
22-26 AWG termination capable	Works with all commonly used solid and stranded shielded cabling
TG-style termination technology	Proven electrical performance and quick installation speed from the same forward-motion termination technology used in the Panduit Mini-Com® TG Modular Jacks
Category 6A, 6, and 5e compatibility	High performance capability and wide cable size range enable a single plug for all common shielded cabling systems
Re-termination	Ability to re-terminate up to 20 times with no additional parts, providing convenience and cost-savings in cases when plug must be re-terminated to cable
Compact termination tools	EGPT is fold-able and lightweight

TX6A™ Shielded Field Term Plug

Field Term Plug: FPS6X88MTG

Field Term Plug 10 pk: FPS6X88MTG-X

Tools and Accessories

Termination Tool: EGPT or EGJT-1

Wire Stripping Tool: CJUST

Wire Snipping Tool: CWST

Optional Test Cord: FPS6X88TC

Shielded Straight Field Term Plug Wire Caps 10 pk: CPSCAPBL-X

TX6A™ Shielded Field Term RJ45 Plug

Dimensions

Shielded Field Term Plug “without” Protective Cap

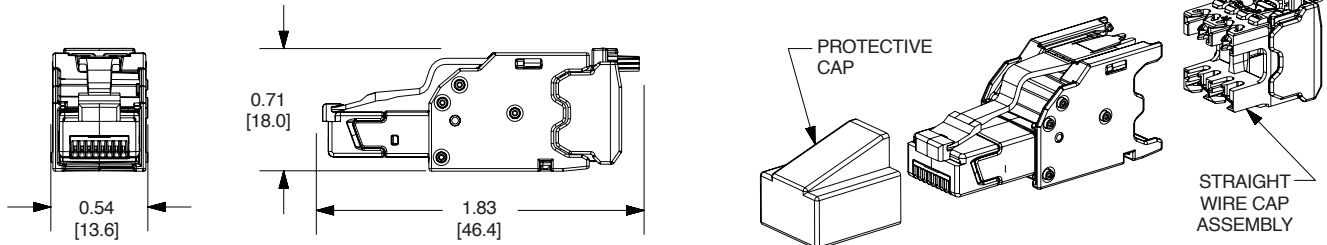

Shielded Field Term Plug “with” Protective Cap

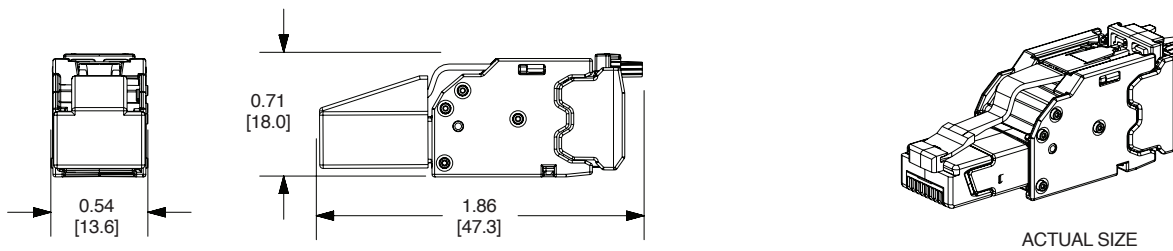

Shielded Straight Wire Cap Assembly

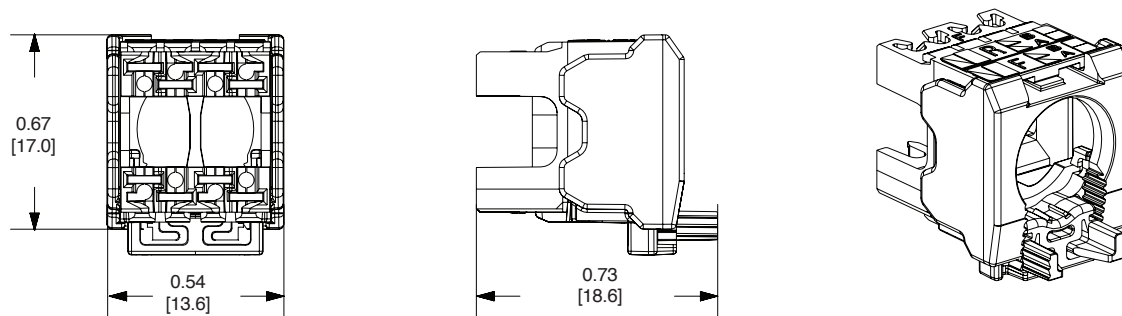

Dimensions are in inches. [Dimensions in brackets are metric.]

WORLDWIDE SUBSIDIARIES AND SALES OFFICES

PANDUIT US/CANADA
Phone: 800.777.3300

PANDUIT EUROPE LTD.
London, UK
Phone: 44.20.8601.7200

PANDUIT SINGAPORE PTE. LTD.
Republic of Singapore
Phone: 65.6305.7575

PANDUIT JAPAN
Tokyo, Japan
Phone: 81.3.6863.6000

PANDUIT LATIN AMERICA
Guadalajara, Mexico
Phone: 52.33.3777.6000

PANDUIT INTERNATIONAL LTD.
Victoria, Australia
Phone: 61.3.9794.9020

For a copy of Panduit product warranties, log on to www.panduit.com/warranty

PANDUIT™

For more information
Visit us at www.panduit.com

© 2018 Panduit Corp.
ALL RIGHTS RESERVED.
COSP460--WW-UKE
11/2018