

| REVISION HISTORY | | | | |
|------------------|-----|-------------|-----------|----------|
| ZONE | REV | DESCRIPTION | DATE | APPROVED |
| All | 1 | Released | 1/29/2018 | ATK |

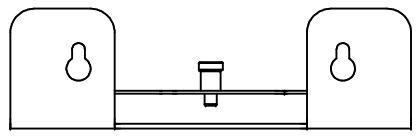
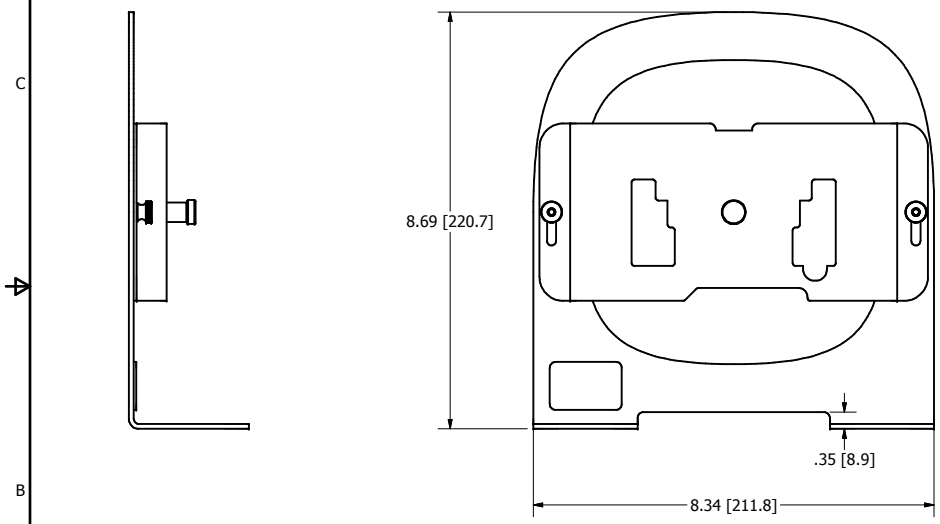
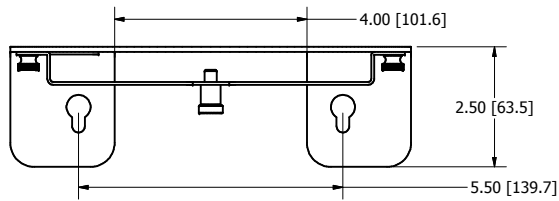

ORDERING INFORMATION:

MANUFACTURER/MODEL: OBERON ENCLOSURE MODEL:

- | | |
|---------------------------|----------------------|
| Cisco 2600/2700/3500/3700 | Model 1006-CCOAP |
| Cisco 2800/3800 | Model 1006-CCOAP3800 |
| Cisco HLA | Model 1006-HLA |
| Aruba Networks AP225 | Model 1006-AP225 |
| Aruba Networks AP305 | Model 1006-AP305 |
| Aruba Networks AP325 | Model 1006-AP325 |
| Aruba Networks AP335 | Model 1006-AP335 |
| Extreme Networks 3925 | Model 1006-EX3900 |

NOTES:

- Weight: 6 lbs.
- Material: 10 Gauge Steel Base White Powder Coat
16 Gauge Steel Mounting Bracket White Powder Coat

Includes:

- Installation Hardware for Access Point
- Hardware for wall attachment supplied by customer

NOTE: All materials used in the construction of Oberon products must be RoHS compliant and meet RoHS2 Directive 2011/65/EU. Contact Oberon engineering if RoHS compliant materials are not available.

| | | | | |
|-----------------|--|--|----------------|----------|
| DRAWN RLC | 5/24/2016 | Oberon, Inc. - 1315 S. Allen St. - State College, PA 16801 | | |
| CHECKED RLC | 6/30/2017 | TITLE | | |
| QA | | Model 1006-AP305 | | |
| MFG RLC | 6/30/2017 | SIZE C | DWG NO 3100 | REV 1 |
| APPROVED RLC | 6/30/2017 | SCALE | SHEET 1 OF 2 | |
| TOLERANCE: | .0 = +/- .030 .00 = +/- .015 .000 = +/- .005 | | | |