

REV	DATE	DESCRIPTION	ECO	BY	CHK.
A	11/01/2018	NEW DRAWING CREATION	50194	WP	SV

WIRE SIZE (AWG), AN Aircraft	STUD SIZE	CATALOG NUMBER	BULK CATALOG NUMBER	AS25036 DASH NO.	SAE CLASS #		C		K		L MAX.	N		T ±.01 [±.25]	Y MAX.	Z MIN.	WIRE STRIP LENGTH ±.03 [±.8]	DIE INDEX					
					1	2	MAX.	MIN.	MAX.	MIN.		MAX.	MIN.										
8 Str. and Sol.	8	-	YAV8CL14	140	X	-			.18 [4.5]	.16 [4.1]	1.15 [29.2]	.21 [5.4]	.19 [4.9]	.08 [2.0]	.94 [23.8]	.28 [7.2]	38						
	10	YAV8CLBOX	YAV8CL	107	X	-	.43 [10.8]	.39 [9.8]	.23 [5.8]	.19 [4.8]													
		-	YAV8CLBOX500	-	-	-																	
	1/4"	YAV8CL1BOX	YAV8CL1	141	X	X	.48 [12.1]	.44 [11.0]	.28 [7.1]	.26 [6.6]								1.22 [31.0]	.24 [6.0]	.22 [5.5]	.07 [1.8]	.98 [24.9]	.33 [8.3]
		-	YAV8CL1BOX500	-	-	-															.07 [1.8]	.99 [25.1]	.32 [8.1]
	5/16"	YAV8CL2BOX	YAV8CL2	108	X	-	.59 [14.9]	.55 [13.9]	.34 [8.6]	.32 [8.1]								1.30 [32.9]	.29 [7.5]	.27 [7.0]	.06 [1.4]	1.00 [25.5]	.35 [8.9]
	3/8"	YAV8CL3BOX	YAV8CL3	129	X	-			.40 [10.2]	.38 [9.7]													
1/2"	YAV8CL4BOX	YAV8CL4	142	X	-	.75 [19.0]	.71 [18.0]	.54 [13.7]	.51 [13.1]	1.52 [38.6]	.39 [9.9]	.37 [9.4]	.04 [1.1]	1.14 [29.0]	.48 [12.2]								
6 Str. and Sol.	10	YAV6CL1BOX	YAV6CL1	130	X	-	.50 [12.7]	.46 [11.7]	.23 [5.8]	.19 [4.8]	1.31 [33.2]	.25 [6.4]	.23 [5.8]	.08 [2.0]	1.06 [26.8]	.29 [7.4]	1/2" [12.7]						
	1/4"	YAV6CLBOX	YAV6CL	109	X	X	.50 [12.7]	.46 [11.7]	.28 [7.1]	.26 [6.6]	1.28 [32.5]							.07 [1.8]					
		-	YAV6CLBOX500	-	-	-	.52 [13.2]	.48 [12.2]															
	5/16"	YAV6CL4BOX	YAV6CL4	131	X	-	.62 [15.7]	.58 [14.7]	.34 [8.6]	.32 [8.1]	1.43 [36.3]							.31 [7.9]	.29 [7.4]	.06 [1.6]	1.12 [28.4]	.36 [9.0]	
	3/8"	YAV6CL2BOX	YAV6CL2	110	X	-			.40 [10.2]	.38 [9.7]													
	1/2"	YAV6CL10BOX	YAV6CL10	143	X	-	.76 [19.3]	.72 [18.3]	.54 [13.7]	.51 [13.1]	1.64 [41.7]							.39 [9.9]	.37 [9.4]		1.26 [32.0]	.49 [12.4]	
4 Str. and Sol.	10	YAV4CL3BOX	YAV4CL3	144	X	-	.57 [14.4]	.53 [13.4]	.23 [5.8]	.19 [4.8]	1.37 [34.7]	.26 [6.6]	.24 [6.1]	.08 [1.9]	1.11 [28.2]	.28 [7.2]	40						
	1/4"	YAV4CLBOX	YAV4CL	111	X	X			.28 [7.1]	.26 [6.6]													
	5/16"	YAV4CL4BOX	YAV4CL4	132	X	-			.34 [8.6]	.32 [8.1]					1.16 [29.5]	.34 [8.5]							
	3/8"	YAV4CL2BOX	YAV4CL2	112	X	-	.64 [16.4]	.60 [15.4]	.40 [10.2]	.38 [9.7]	1.48 [37.7]	.32 [8.2]	.30 [7.7]										
	10 mm	-	YAV4CL22	-	-	-			.43 [10.9]	.40 [10.2]					.07 [1.8]	1.17 [29.7]		.33 [8.4]					
	1/2"	YAV4CL5BOX	YAV4CL5	145	X	-	.75 [19.0]	.71 [18.0]	.54 [13.7]	.51 [13.1]	1.68 [42.7]	.38 [9.8]	.36 [9.3]		.06 [1.6]	1.24 [31.4]		.47 [11.9]					

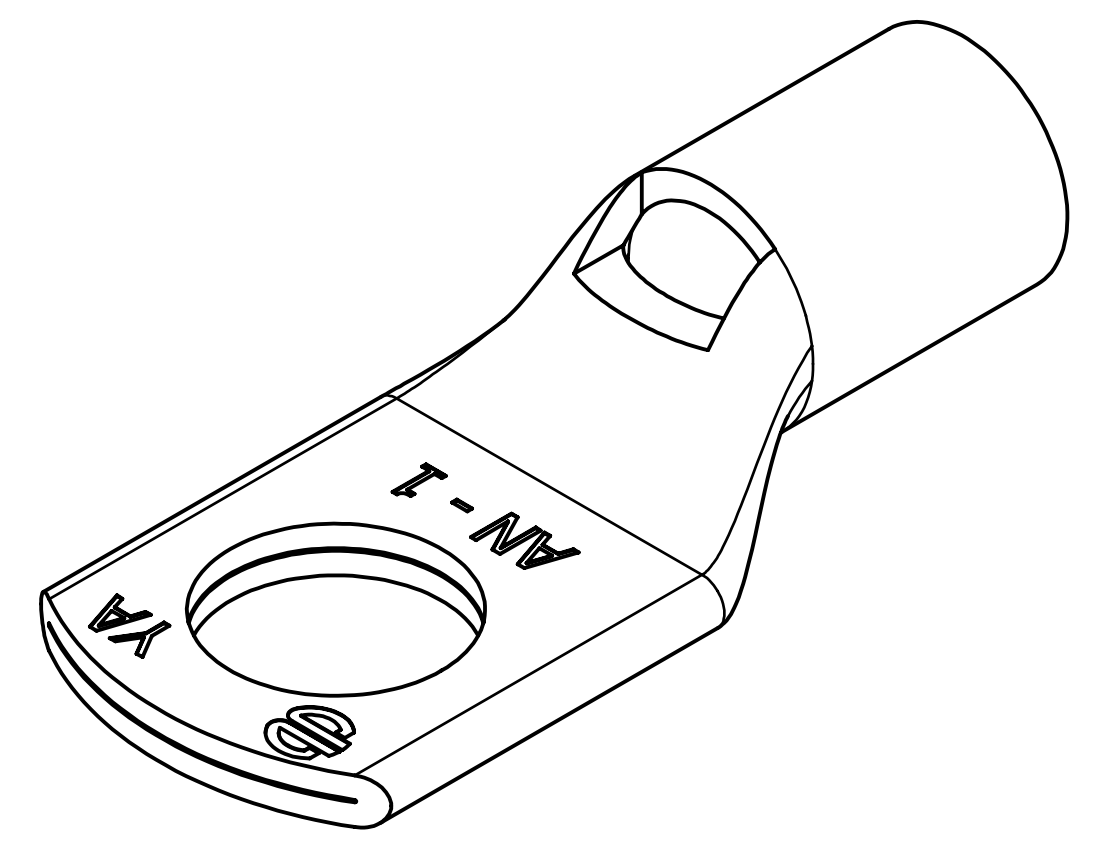
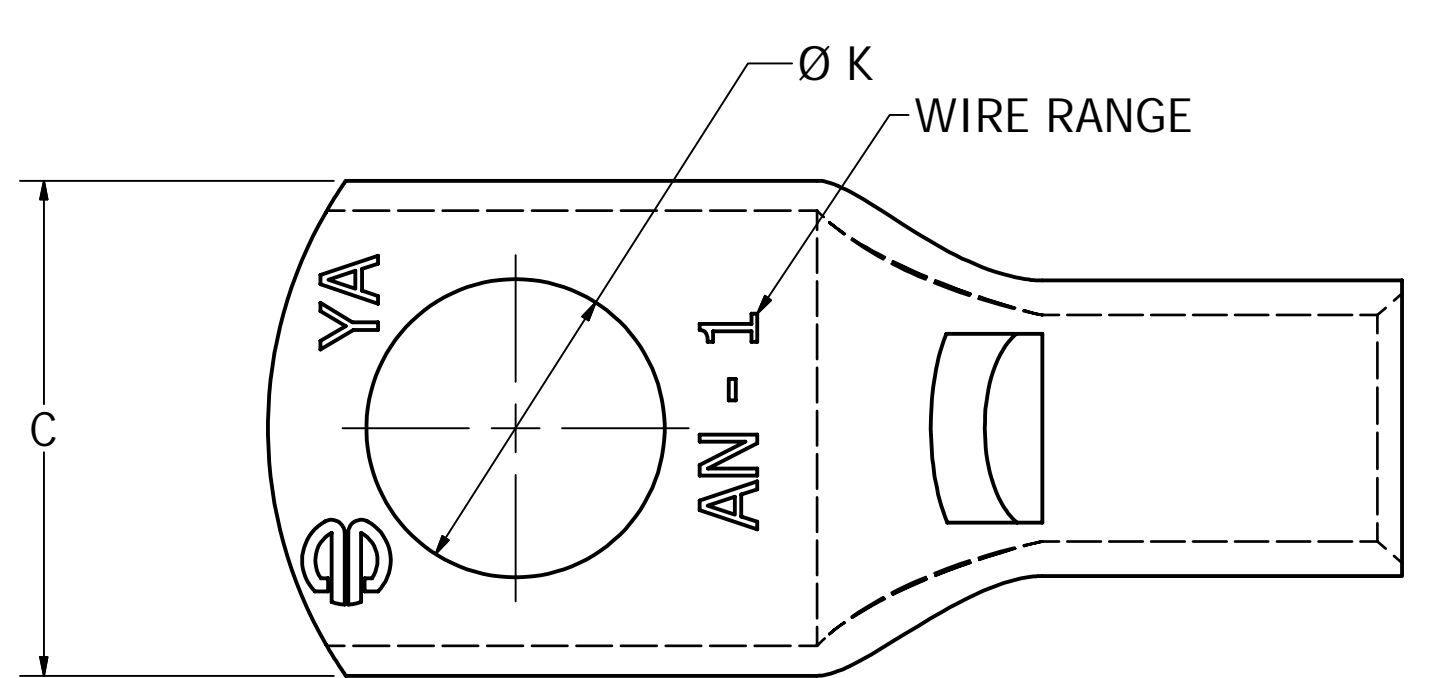
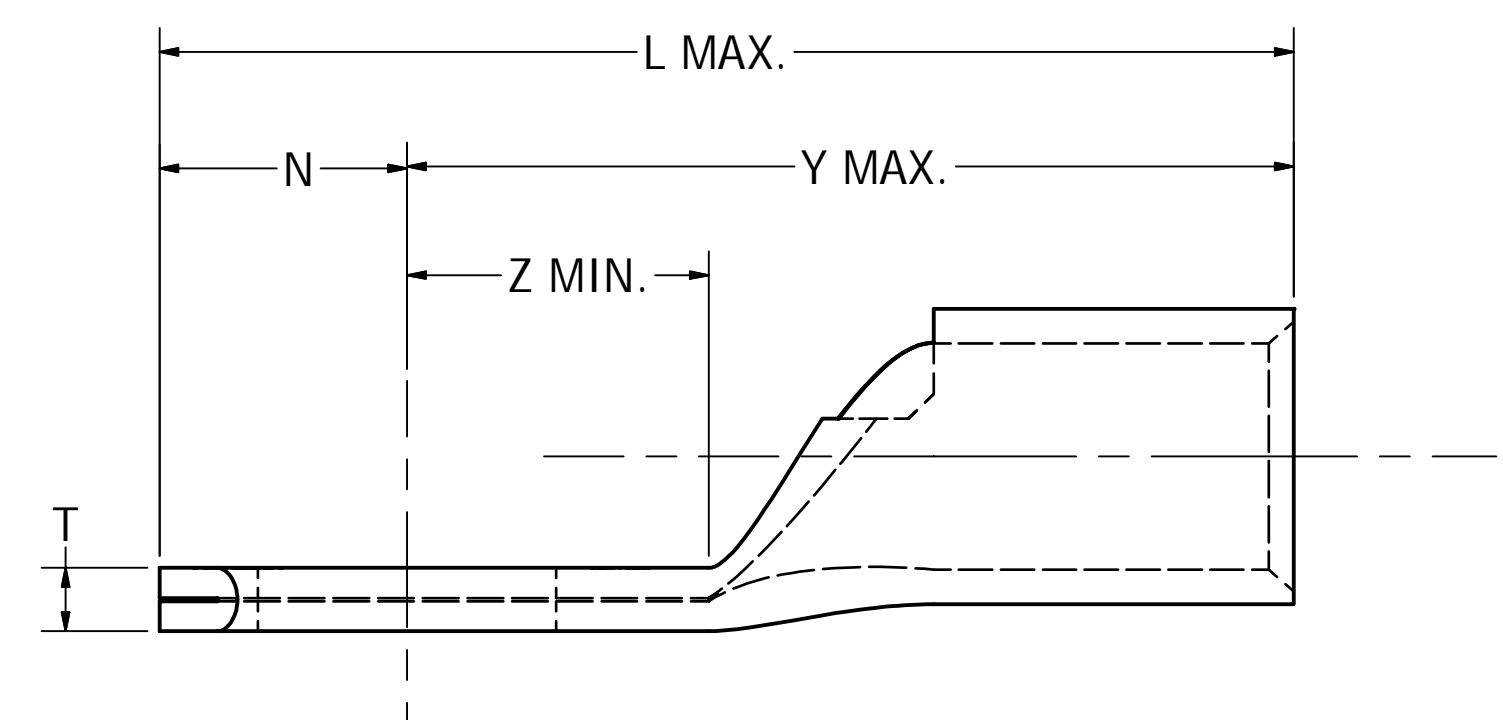

- NOTES:
1. TERMINAL: TIN PLATED COPPER
 2. DIMENSIONS IN BRACKETS [] ARE IN MILLIMETERS AND ARE FOR REFERENCE ONLY.
 3. UL LISTED WIRE CONNECTORS PER UL486A/B (FILE E9498) REQUIREMENTS
 4. CSA CERTIFIED WIRE CONNECTORS PER CSA C22.2 NO. 65 REQUIREMENTS (FILE 42862) ONLY FOR STRANDED WIRE
 5. MEETS REQUIREMENTS OF SAE-AS7928 (MAIN OFFICE CAGE CODE NUMBER: 1NJK8)
 6. AVAILABLE IN (90°) RIGHT ANGLE DESIGN. SUFFIX "RS" REPLACES SUFFIX "L".
 7. ADD "NK" SUFFIX FOR NICKEL PLATED HYLUGS FOR HIGH TEMPERATURE APPLICATIONS UP TO 650°F CONTINUOUS SERVICE AND 750°F INTERMITTENT SERVICE.

TO ORDER BURNDY® PRODUCTS CALL		HYLUG	
UNITED STATES 1-800-346-4175 (LONDONDERRY, NH)		ITEM NO: SEE TABLE	
CANADA: 1-800-361-6975 (QUEBEC) 1-800-387-6487 (ALL OTHER PROVINCES)		CAT. NO: TYPE YAV - L	
FOR PRODUCT INFO: http://www.burndy.com		DRAWN BY: P.WINSON 11/01/2018 CHECKER: S.VENKATESAN 11/01/2018 DSN APRVL: K.CASTONGUAY 12/13/2018 MFG APRVL: -- QA APRVL: B.POST 11/28/2018 MKT APRVL: M.BAILLY 11/27/2018 PROD FAM: --	
		PROJECT #: -- SIZE: D DOCUMENT TYPE: SALES REL LEVEL: Released	
		DRAWING NO: 50094161 SHEET 1 OF 3	
		REV: A	

WIRE SIZE (AWG), AN Aircraft	STUD SIZE	CATALOG NUMBER	BULK CATALOG NUMBER	AS25036 DASH NO.	SAE CLASS #		C		K		L MAX.	N		T ± .01 [± .25]	Y MAX.	Z MIN.	WIRE STRIP LENGTH ± .03 [± .8]	DIE INDEX
					1	2	MAX.	MIN.	MAX.	MIN.		MAX.	MIN.					
2 Str. and Sol.	10	YAV2CL3BOX	YAV2CL3	146	X	-	.71 [18.0]	.67 [17.0]	.23 [5.8]	.19 [4.8]	1.72 [43.7]	.35 [9.0]	.33 [8.5]	.10 [2.5]	1.37 [34.7]	.35 [9.0]	5/8" [15.9]	41
	1/4"	YAV2CL1BOX	YAV2CL1	113	X	-			.28 [7.1]	.26 [6.6]								
	5/16"	YAV2CL2BOX	YAV2CL2	147	X	X			.34 [8.6]	.32 [8.1]								
	3/8"	YAV2CLBOX	YAV2CL	114	X	-			.40 [10.2]	.38 [9.7]								
	10 mm	-	YAV2CL26	-	-	-			.43 [10.9]	.40 [10.2]								
1 Str. and Sol.	1/2"	YAV2CL4BOX	YAV2CL4	133	X	-	.79 [20.1]	.75 [19.0]	.54 [13.7]	.51 [13.1]	1.88 [47.7]	.40 [10.0]	.38 [9.5]	.09 [2.2]	1.48 [37.7]	.47 [11.9]	11/16" [17.5]	43
		-	YAV2CL56	-	-	-	.85 [21.6]	.81 [20.6]	.54 [13.7]	.51 [13.1]	2.10 [53.3]	.42 [10.7]	.40 [10.2]		1.69 [42.9]	.55 [14.0]		
	10	-	YAV1CL6	-	-	-	.78 [19.8]	.74 [18.8]	.23 [5.8]	.19 [4.8]	1.67 [42.3]	.35 [9.0]	.33 [8.5]	.12 [2.9]	1.29 [32.8]	.25 [6.4]		
	1/4"	YAV1CL1BOX	YAV1CL1	115	X	X			.28 [7.1]	.26 [6.6]								
	5/16"	YAV1CL2BOX	YAV1CL2	149	X	-			.34 [8.6]	.32 [8.1]								
	3/8"	YAV1CLBOX	YAV1CL	116	X	-			.40 [10.2]	.38 [9.7]	1.84 [46.7]	.39 [9.9]	.37 [9.4]		1.45 [36.8]	.38 [9.7]		
		-	YAV1CL18	-	-	-					1.99 [50.5]				1.60 [40.6]	.53 [13.5]		
7/16"	-	YAV1CL4	150	X	-	.88 [22.4]	.84 [21.3]	.46 [11.8]	.45 [11.4]	1.97 [50.0]	.44 [11.2]	.42 [10.7]	.11 [2.8]	1.53 [38.9]	.47 [11.9]			
1/2"	YAV1CL3BOX	YAV1CL3	134	X	-	.86 [21.8]	.82 [20.8]	.54 [13.7]	.51 [13.1]	2.43 [61.7]	.51 [13.0]	.49 [12.4]	.10 [2.6]	1.54 [39.1]	.46 [11.7]			
5/8"	-	YAV1CL5	-	-	-	1.08 [27.4]	1.04 [26.4]	.67 [16.9]	.65 [16.5]					1.92 [48.8]	.86 [21.8]			
1/0 Str. and Sol.	1/4"	YAV25L1BOX	YAV25L1	117	X	-	.85 [21.6]	.81 [20.6]	.28 [7.1]	.26 [6.6]	2.03 [51.6]	.43 [10.9]	.41 [10.4]	.11 [2.8]	1.61 [40.9]	.43 [10.9]		
	5/16"	YAV25L2BOX	YAV25L2	151	X	-			.34 [8.6]	.32 [8.1]								
	3/8"	YAV25LBOX	YAV25L	118	X	X			.40 [10.2]	.38 [9.7]								
	7/16"	-	YAV25L16	152	X	-	.90 [22.9]	.86 [21.8]	.46 [11.8]	.45 [11.4]	2.09 [53.1]	.45 [11.4]	.43 [10.9]		1.64 [41.6]	.47 [11.9]		
		-	YAV25L16G1	-	-	-	.85 [21.6]	.81 [20.6]	.46 [11.8]	.45 [11.4]								
	1/2"	YAV25L3BOX	YAV25L3	135	X	-	.90 [22.9]	.86 [21.8]	.54 [13.7]	.51 [13.1]								
		-	YAV25L3G2	-	-	-	.85 [21.6]	.81 [20.6]	.54 [13.7]	.51 [13.1]				.19 [4.8]				
	5/8"	YAV25L4BOX	YAV25L4	-	-	-	.90 [22.9]	.86 [21.8]	.67 [16.9]	.65 [16.5]	2.30 [58.5]	.51 [13.0]	.49 [12.4]	.11 [2.8]	1.80 [45.6]	.62 [15.9]		
3/4"	-	YAV25L23	-	-	-	.97 [24.7]	.93 [23.7]	.78 [19.9]	.77 [19.6]	2.49 [63.2]	.64 [16.1]	.62 [15.6]	.10 [2.6]	1.86 [47.1]	.68 [17.4]			

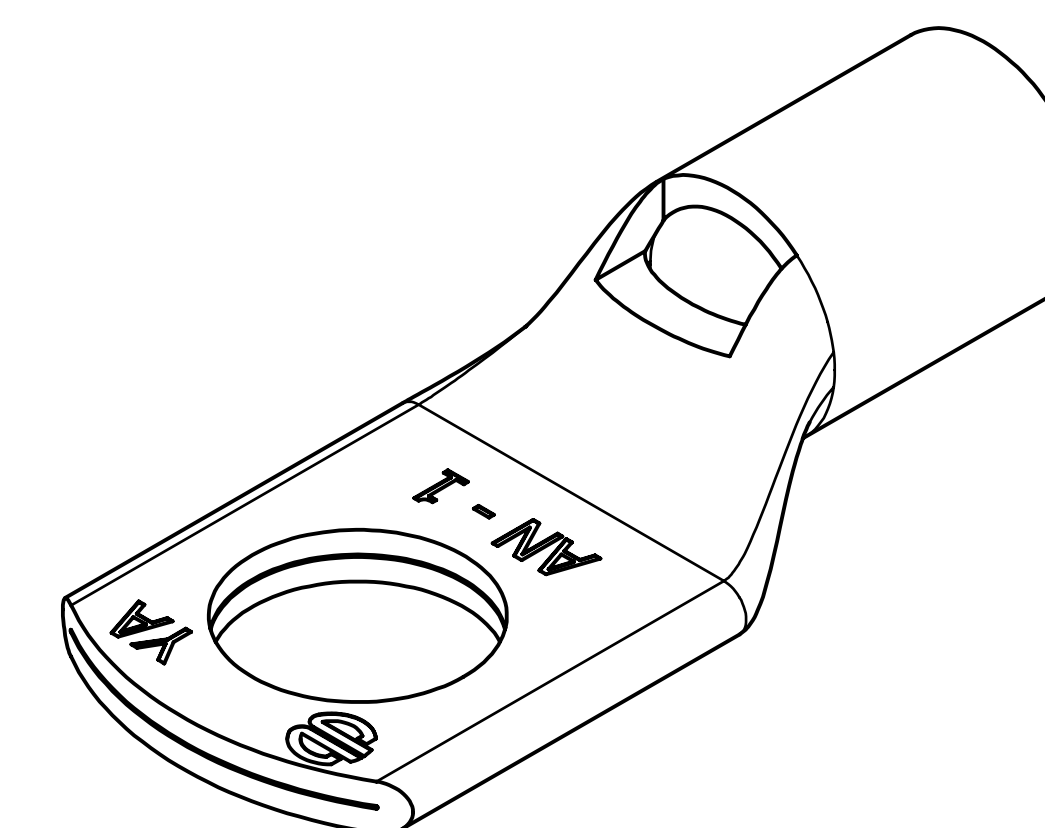
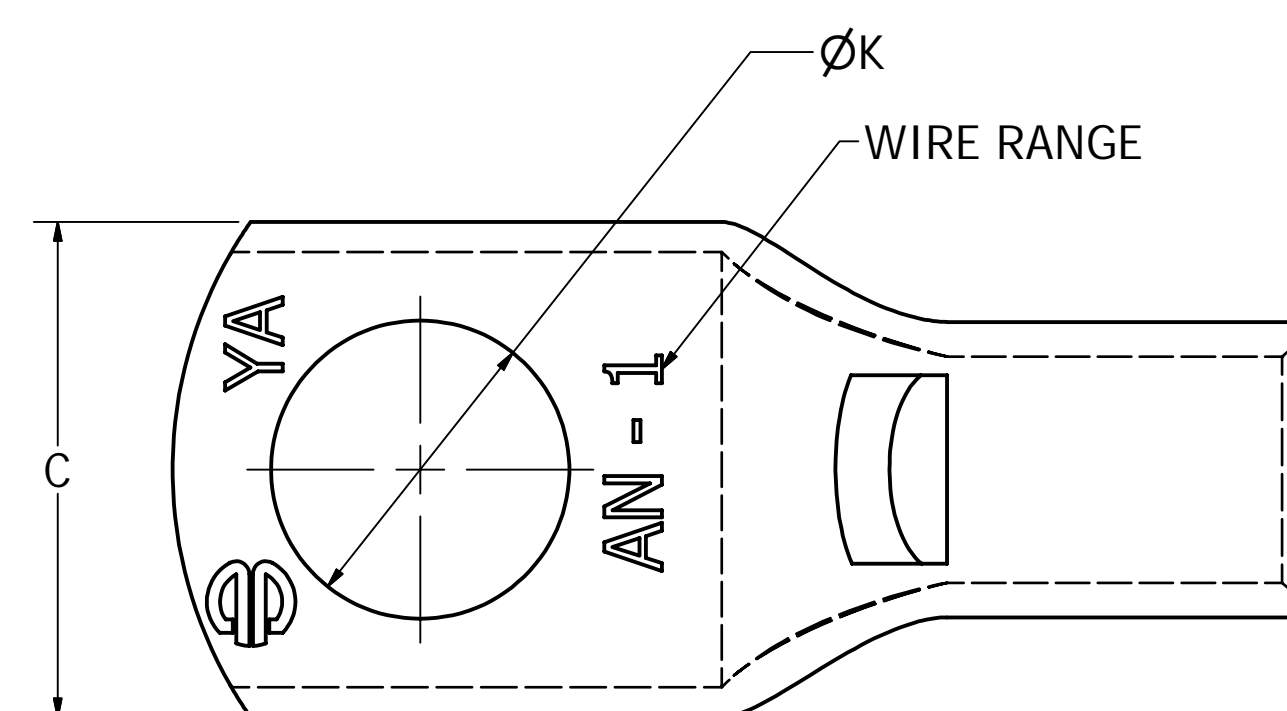
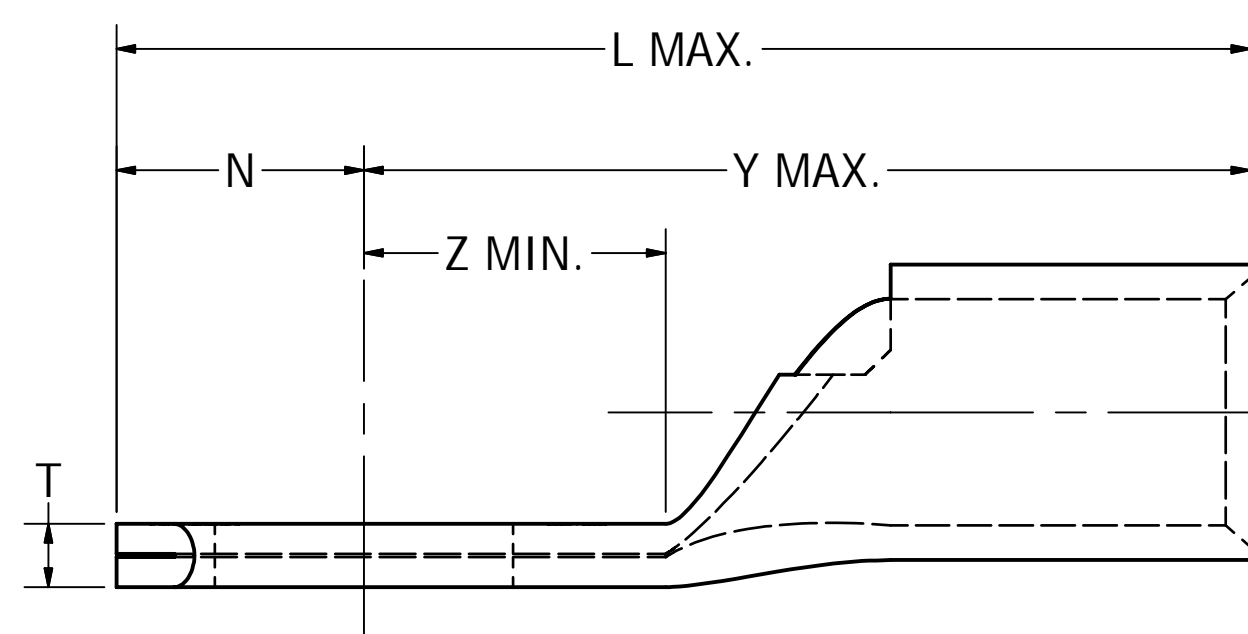

- NOTES:
1. TERMINAL: TIN PLATED COPPER
 2. DIMENSIONS IN BRACKETS [] ARE IN MILLIMETERS AND ARE FOR REFERENCE ONLY.
 3. UL LISTED WIRE CONNECTORS PER UL486A/B (FILE E9498) REQUIREMENTS
 4. CSA CERTIFIED WIRE CONNECTORS PER CSA C22.2 NO. 65 REQUIREMENTS (FILE 42862) ONLY FOR STRANDED WIRE
 5. MEETS REQUIREMENTS OF SAE-AS7928 (MAIN OFFICE CAGE CODE NUMBER: 1NJK8)
 6. AVAILABLE IN (90°) RIGHT ANGLE DESIGN. SUFFIX "RS" REPLACES SUFFIX "L".
 7. ADD "NK" SUFFIX FOR NICKEL PLATED HYLUGS FOR HIGH TEMPERATURE APPLICATIONS UP TO 650°F CONTINUOUS SERVICE AND 750°F INTERMITTENT SERVICE.

TO ORDER BURNDY® PRODUCTS CALL		HYLUG	
UNITED STATES 1-800-346-4175 (LONDONDERRY, NH)		ITEM NO: SEE TABLE	
CANADA: 1-800-361-6975 (QUEBEC) 1-800-387-6487 (ALL OTHER PROVINCES)		CAT. NO: TYPE YAV - L	
FOR PRODUCT INFO: http://www.burndy.com		DRAWN BY: P.WINSON 11/01/2018	
		CHECKER: S.VENKATESAN 11/01/2018	
		DSN APRVL: K.CASTONGUAY 12/13/2018	
		MFG APRVL: --	
		QA APRVL: B.POST 11/28/2018	
		MKT APRVL: M.BAILLY 11/27/2018	
		PROD FAM: --	
		PROJECT #: --	
		DOCUMENT TYPE: SALES	
		REL LEVEL: Released	
		SIZE: D	
		DRAWING NO: 50094161	
		SHEET 2 OF 3	
		REV: A	

REV	DATE	DESCRIPTION	ECO	BY	C'H.K.
A	11/01/2018	NEW DRAWING CREATION	50194	WP	SV

WIRE SIZE (AWG), AN Aircraft	STUD SIZE	CATALOG NUMBER	BULK CATALOG NUMBER	AS25036 DASH NO.	SAE CLASS #		C		K		L MAX.	N		T ±.01 [±.25]	Y MAX.	Z MIN.	WIRE STRIP LENGTH ±.03 [±.8]	DIE INDEX			
					1	2	MAX.	MIN.	MAX.	MIN.		MAX.	MIN.								
2/0 Str. and Sol.	1/4"	YAV26L1BOX	YAV26L1	153	X	-	.95 [24.2]	.91 [23.2]	.28 [7.1]	.26 [6.6]	2.32 [58.9]	.48 [12.1]	.46 [11.6]	.11 [2.9]	1.85 [46.9]	.48 [12.2]		44			
	5/16"	YAV26L2BOX	YAV26L2	119	X	-			.34 [8.6]	.32 [8.1]											
	3/8"	YAV26LBOX	YAV26L	120	X	-			.40 [10.2]	.38 [9.7]											
	10 mm	-	YAV26L31	-	-	-			.43 [10.9]	.40 [10.2]	2.10 [53.4]	.40 [10.2]	.38 [9.7]								
	7/16"	-	YAV26L16	154	X	-			.46 [11.8]	.45 [11.4]	2.32 [58.9]	.48 [12.1]	.46 [11.6]						.13 [3.2]		
	1/2"	YAV26L3BOX	YAV26L3	136	X	X			.54 [13.7]	.51 [13.1]	.11 [2.9]	1.85 [46.9]	.48 [12.3]								
	5/8"	YAV26L12BOX	YAV26L12	-	-	-			.67 [16.9]	.65 [16.5]	2.52 [64.1]	.54 [13.7]	.52 [13.2]						.13 [3.2]	1.98 [50.4]	.63 [15.9]
	3/4"	-	YAV26L22	-	-	-			1.14 [29.0]	1.10 [27.9]	.78 [19.9]	.77 [19.6]	2.66 [67.7]						.51 [13.0]	.49 [12.4]	.12 [3.0]
3/0 Str. and Sol.	1/4"	-	YAV27L17	-	-	-	1.05 [26.7]	1.01 [25.7]	.28 [7.1]	.26 [6.6]	2.38 [60.3]	.45 [11.4]	.43 [10.9]	.14 [3.5]	1.93 [49.0]	.52 [13.3]	13/16" [20.6]	45			
	5/16"	-	YAV27L20	155	X	-			.34 [8.6]	.32 [8.1]	2.45 [62.3]	.52 [13.3]	.50 [12.8]								
	3/8"	YAV27LBOX	YAV27L	121	X	X			.40 [10.2]	.38 [9.7]	2.37 [60.1]	.49 [12.5]	.47 [12.0]						1.87 [47.6]	.47 [11.9]	
		-	YAV27L42	-	-	-	.83 [21.0]	.79 [20.0]	2.35 [59.7]	.42 [10.7]	.40 [10.2]	.15 [3.8]	1.93 [49.0]	.52 [13.3]							
	7/16"	-	YAV27L18	156	X	-	1.05 [26.7]	1.01 [25.7]	.46 [11.8]	.45 [11.4]	2.45 [62.3]	.52 [13.3]	.50 [12.8]	.14 [3.5]	2.03 [51.6]	.63 [15.9]	7/8" [22.2]	46			
	1/2"	YAV27L1BOX	YAV27L1	122	X	-			.54 [13.7]	.51 [13.1]	2.60 [66.1]	.57 [14.5]	.55 [14.0]						2.09 [53.1]	.69 [17.5]	
	5/8"	YAV27L15BOX	YAV27L15	-	-	-			.67 [16.9]	.65 [16.5]	2.73 [69.3]	.64 [16.1]	.62 [15.6]						2.16 [54.7]	.60 [15.4]	
	3/4"	-	YAV27L22	-	-	-	1.14 [29.0]	1.10 [27.9]	.78 [19.9]	.77 [19.6]	2.95 [74.9]	.62 [15.9]	.60 [15.4]	.13 [3.4]	2.32 [59.1]	.78 [19.8]					
4/0 Str. and Sol.	1/4"	YAV28L53BOX	YAV28L53	-	-	-	1.14 [29.0]	1.10 [27.9]	.28 [7.1]	.26 [6.6]	2.28 [57.8]	.45 [11.4]	.43 [10.9]	.14 [3.5]	2.16 [54.7]	.60 [15.4]	7/8" [22.2]	46			
	5/16"	-	YAV28L56	157	X	-			.34 [8.6]	.32 [8.1]	2.72 [69.1]	.57 [14.5]	.55 [14.0]								
	3/8"	YAV28LBOX	YAV28L	123	X	-			.40 [10.2]	.38 [9.7]	2.38 [60.5]	.49 [12.5]	.47 [12.0]						1.89 [48.1]	.34 [8.7]	
		-	YAV28L76	-	-	-	.43 [10.9]	.40 [10.2]	2.72 [69.1]	.57 [14.5]	.55 [14.0]	2.16 [54.7]	.60 [15.4]								
	10 mm	-	YAV28L67	-	-	-	1.25 [31.8]	1.21 [30.7]	.46 [11.8]	.45 [11.4]	2.95 [74.9]	.62 [15.9]	.60 [15.4]	.13 [3.4]	2.32 [59.1]	.78 [19.8]					
	7/16"	-	YAV28L60	158	X	-			.54 [13.7]	.51 [13.1]											
	1/2"	YAV28L12BOX	YAV28L12	124	X	X			.67 [16.9]	.65 [16.5]											
	5/8"	YAV28L13BOX	YAV28L13	159	X	-	1.25 [31.8]	1.21 [30.7]	.78 [19.9]	.77 [19.6]	2.95 [74.9]	.62 [15.9]	.60 [15.4]	.13 [3.4]	2.32 [59.1]	.78 [19.8]					
3/4"	YAV28L14BOX	YAV28L14	160	X	-	1.25 [31.8]	1.21 [30.7]	.78 [19.9]	.77 [19.6]	2.95 [74.9]	.62 [15.9]	.60 [15.4]	.13 [3.4]	2.32 [59.1]	.78 [19.8]						

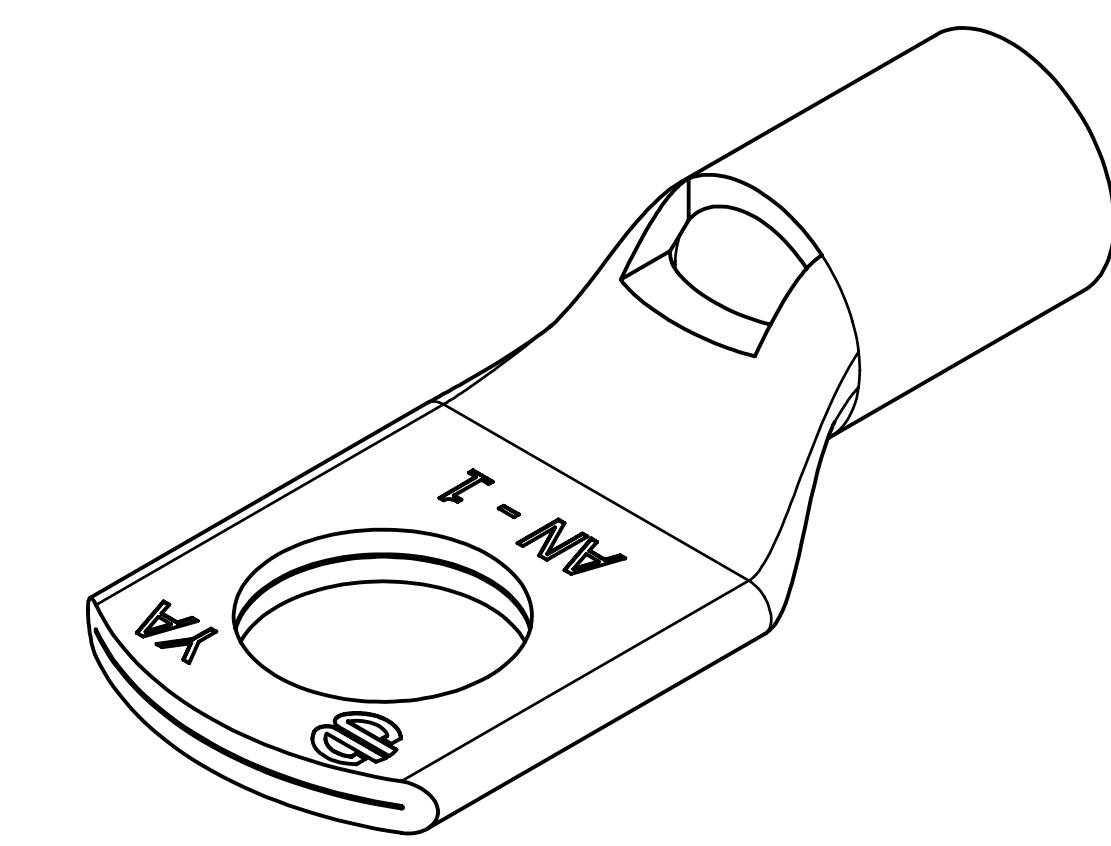
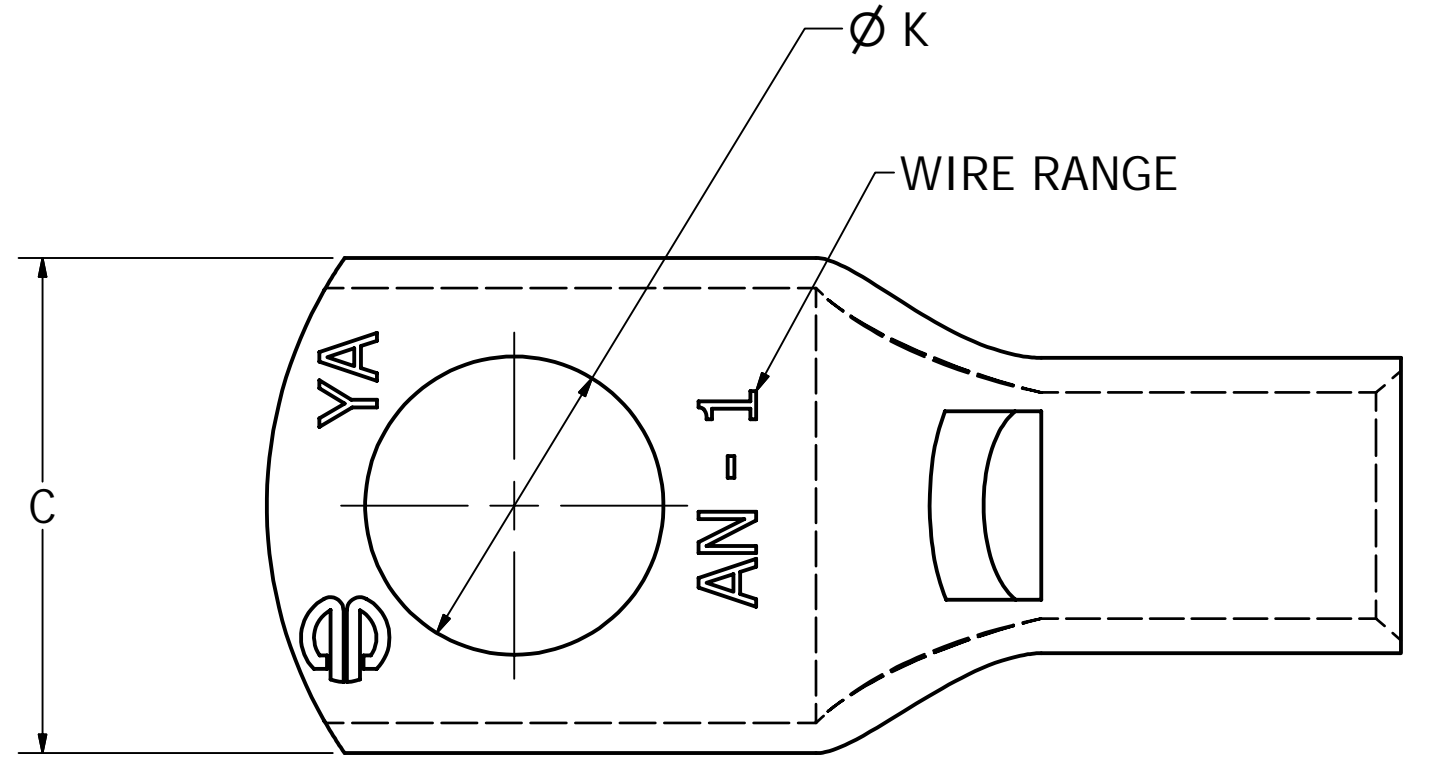
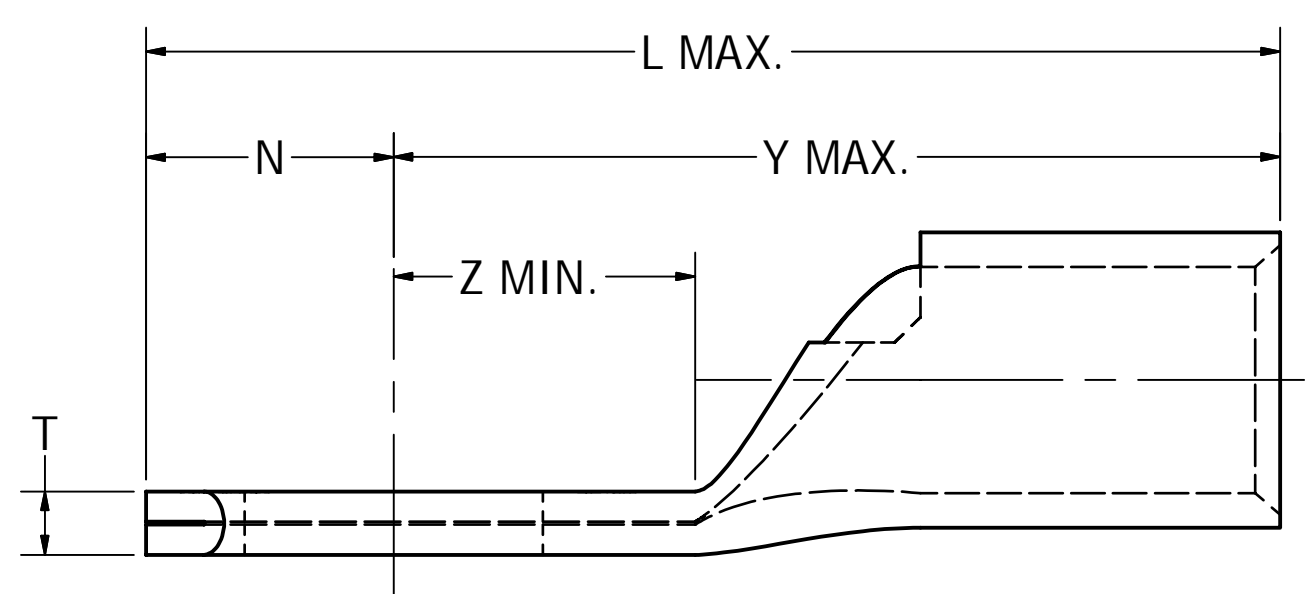

- NOTES:
1. TERMINAL: TIN PLATED COPPER
 2. DIMENSIONS IN BRACKETS [] ARE IN MILLIMETERS AND ARE FOR REFERENCE ONLY.
 3. UL LISTED WIRE CONNECTORS PER UL486A/B (FILE E9498) REQUIREMENTS
 4. CSA CERTIFIED WIRE CONNECTORS PER CSA C22.2 NO. 65 REQUIREMENTS (FILE 42862) ONLY FOR STRANDED WIRE
 5. MEETS REQUIREMENTS OF SAE-AS7928 (MAIN OFFICE CAGE CODE NUMBER: 1NJK8)
 6. AVAILABLE IN (90°) RIGHT ANGLE DESIGN. SUFFIX "RS" REPLACES SUFFIX "L".
 7. ADD "NK" SUFFIX FOR NICKEL PLATED HYLUGS FOR HIGH TEMPERATURE APPLICATIONS UP TO 650°F CONTINUOUS SERVICE AND 750°F INTERMITTENT SERVICE.

TO ORDER BURNDY® PRODUCTS CALL		HYLUG	
UNITED STATES 1-800-346-4175 (LONDONDERRY, NH)		ITEM NO: SEE TABLE	
CANADA: 1-800-361-6975 (QUEBEC) 1-800-387-6487 (ALL OTHER PROVINCES)		CAT. NO: TYPE YAV - L	
FOR PRODUCT INFO: http://www.burndy.com		DRAWN BY: P.WINSON 11/01/2018	
		CHECKER: S.VENKATESAN 11/01/2018	
		DSN APRVL: K.CASTONGUAY 12/13/2018	
		MFG APRVL: --	
		QA APRVL: B.POST 11/28/2018	
		MKT APRVL: M.BAILLY 11/27/2018	
		PROD FAM: --	
		PROJECT #: --	
		SIZE: D	
		DOCUMENT TYPE: SALES	
		REL LEVEL: Released	
		DRAWING NO: 50094161	
		SHEET 3 OF 3	
		REV: A	