

WIRE SIZE (AWG)	STUD SIZE	CATALOG NUMBER	BULK CATALOG NUMBER	AS20659 DASH NO.	SAE CLASS #		C		K		L MAX.	N		T ± .01 [± .25]	Y MAX.	Z MIN.	WIRE STRIP LENGTH ± .03 [± .8]	INSTALLATION TOOLING (ONE CRIMP)
					1	2	MAX.	MIN.	MAX.	MIN.		MAX.	MIN.					
22-18 Str. and Sol.	4	YAV18T4BOX	YAV18T4	-	-	-	.20 [5.0]	.18 [4.5]	.12 [3.0]	.11 [2.8]	.62 [15.7]	.10 [2.6]	.08 [2.1]	.05 [1.3]	.54 [13.7]	.16 [4.1]	9/32" [7.1] Y6NCB [J1022NC5], Y6NCP1 [J1022NC5], Y1022, MR8G98, Y8MRB1, Y81KFT, Y81KFTMBH, PAT81KFT18V, MRE1022B, Y122CMR # # # # - Y122CMR only to be used for YAV10 items	
	6	YAV18L33BOX	YAV18L33	-	-	-	.26 [6.6]	.24 [6.1]	.15 [3.8]	.14 [3.6]	.60 [15.2]	.14 [3.4]	.12 [2.9]	.04 [1.0]	.55 [14.0]	.18 [4.6]		
		YAV18T5BOX	YAV18T5	-	-	-												
	8	YAV18T1BOX	YAV18T1	-	-	-	.33 [8.3]	.30 [7.5]	.18 [4.5]	.16 [4.1]	.76 [19.3]	.17 [4.2]	.15 [3.7]	.03 [0.8]	.61 [15.5]	.24 [6.1]		
10	YAV18BOX	YAV18	-	-	-			.23 [5.8]	.19 [4.8]									
20-14 Str. and Sol.	6	YAV14L33BOX	YAV14L33	-	-	-	.27 [6.8]	.23 [5.9]	.15 [3.8]	.14 [3.6]	.67 [17.0]	.14 [3.4]	.12 [2.9]	.05 [1.3]	.59 [15.0]	.18 [4.6]		
		YAV14T5BOX	YAV14T5	-	-	-												
	8	YAV14T1BOX	YAV14T1	-	-	-	.33 [8.3]	.30 [7.5]	.18 [4.5]	.16 [4.1]	.78 [19.8]			.64 [16.3]	.24 [6.1]			
	10	YAV14L36BOX	YAV14L36	-	-	-	.31 [7.9]	.28 [7.1]	.23 [5.8]	.19 [4.8]	.70 [17.8]	.17 [4.2]	.15 [3.7]	.04 [1.0]	.59 [15.0]	.18 [4.6]		
		YAV14BOX	YAV14	-	-	-	.33 [8.3]	.30 [7.5]			.78 [19.8]				.64 [16.3]	.24 [6.1]		
	1/4	YAV14T2BOX	YAV14T2	-	-	-	.44 [11.1]	.41 [10.3]	.28 [7.1]	.26 [6.6]	.99 [25.1]	.26 [6.6]	.24 [6.1]	.03 [0.8]	.75 [19.0]	.32 [8.1]		
5/16	YAV14T3BOX	YAV14T3	-	-	-	.45 [11.5]	.42 [10.7]	.34 [8.6]	.32 [8.1]									
14-12 Str.	10	YAV12G2BOX*	YAV12G2	-	-	-	.31 [8.0]	.28 [7.2]	.23 [5.8]	.19 [4.8]	.78 [19.8]	.17 [4.2]	.15 [3.7]	.04 [0.9]	.67 [17.0]	.24 [6.1]		
	1/4	YAV12G3BOX*	YAV12G3	-	-	-	.38 [9.5]	.34 [8.8]	.28 [7.1]	.26 [6.6]	1.00 [25.4]	.26 [6.6]	.24 [6.1]	.03 [0.8]	.76 [19.3]	.33 [8.4]		
14-10 Str. and Sol.	6	YAV10T7BOX	YAV10T7	165	X	X	.31 [7.8]	.29 [7.4]	.15 [3.8]	.14 [3.6]	.93 [23.6]	.17 [4.2]	.15 [3.7]	.07 [1.8]	.78 [19.8]	.24 [6.1]		
	8	YAV10T11BOX	YAV10T11	-	-	-	.39 [9.9]	.36 [9.1]	.18 [4.5]	.16 [4.1]	.97 [24.6]	.20 [5.0]	.18 [4.5]	.06 [1.5]	.79 [20.1]	.26 [6.6]		
	10	YAV10L36BOX	YAV10L36	-	-	-	.31 [7.9]	.28 [7.1]	.23 [5.8]	.19 [4.8]	.86 [21.8]	.17 [4.2]	.15 [3.7]	.07 [1.8]	.71 [18.0]	.23 [5.8]		
		YAV10BOX	YAV10	105	X	X	.39 [9.9]	.36 [9.1]			.97 [24.6]	.20 [5.0]	.18 [4.5]	.06 [1.5]	.79 [20.1]	.26 [6.6]		
	1/4	YAV10T3BOX	YAV10T3	-	-	-	.48 [12.3]	.45 [11.5]	.28 [7.1]	.26 [6.6]	1.09 [27.7]	.24 [6.2]	.22 [5.7]	.04 [1.1]	.87 [22.1]	.34 [8.6]		
	5/16	YAV10T2BOX	YAV10T2	106	X	X	.55 [13.9]	.52 [13.1]	.34 [8.6]	.32 [8.1]	1.13 [28.7]	.28 [7.0]	.26 [6.5]					
3/8	YAV10T4BOX	YAV10T4	128	X	X	.58 [14.7]	.54 [13.6]	.40 [10.2]	.38 [9.7]	1.17 [29.7]	.29 [7.4]	.27 [6.9]		.88 [22.4]	.37 [9.4]			
10-9 Str.	10	YAV9CL36BOX	YAV9CL36	-	-	-	.33 [8.3]	.30 [7.5]	.23 [5.8]	.19 [4.8]	.94 [23.9]	.17 [4.2]	.15 [3.7]	.07 [1.9]	.83 [21.1]	.15 [3.8]		
	1/4	YAV9CT9BOX	YAV9CT9	-	-	-	.45 [11.5]	.42 [10.7]	.28 [7.1]	.26 [6.6]	1.15 [29.2]	.26 [6.7]	.24 [6.0]	.05 [1.3]	.95 [24.1]	.31 [7.9]		
	5/16	YAV9CT4BOX	YAV9CT4	-	-	-	.55 [13.9]	.48 [12.3]	.34 [8.6]	.32 [8.1]	1.23 [31.2]	.28 [7.1]	.25 [6.4]	.04 [1.1]	1.02 [25.9]	.36 [9.1]		

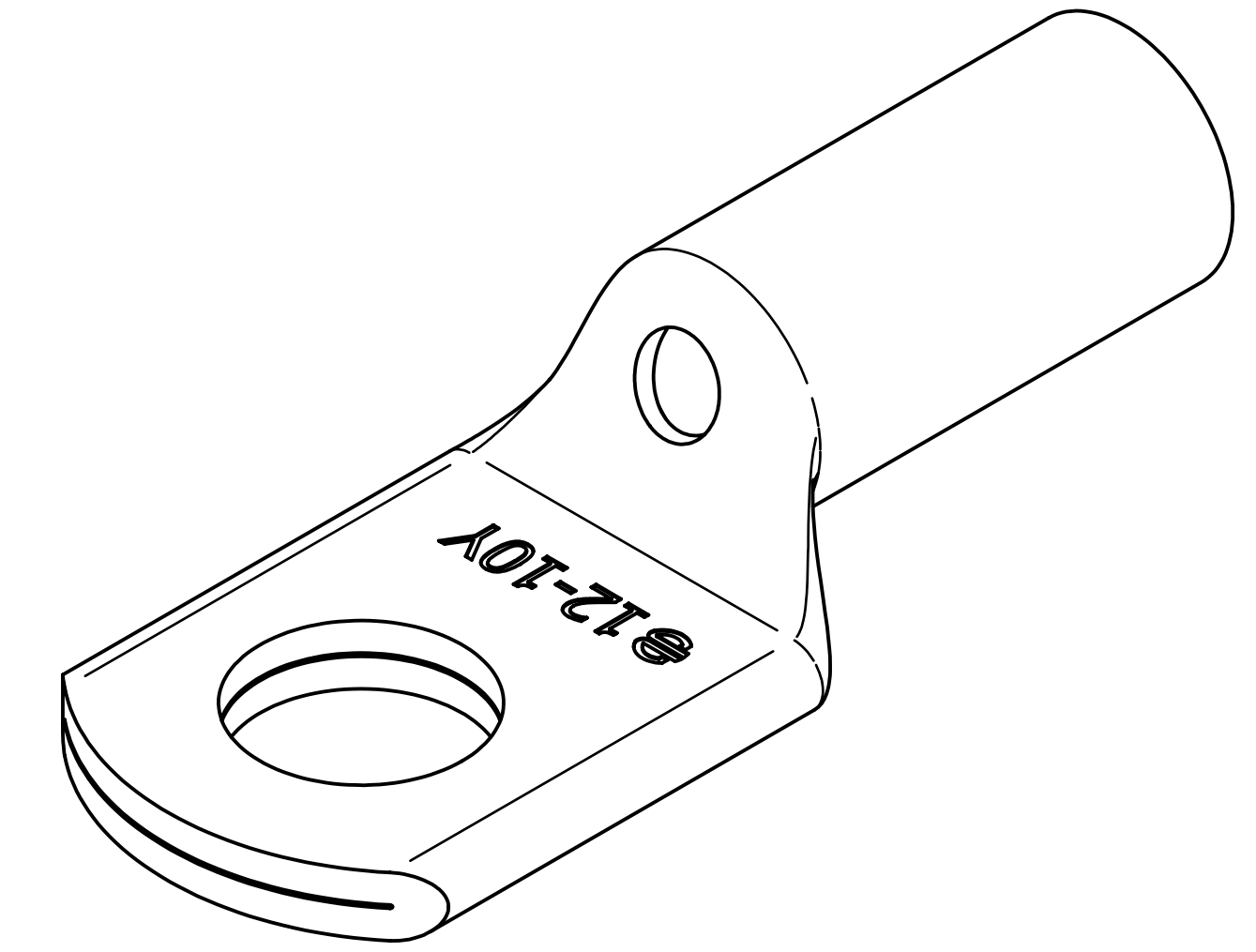
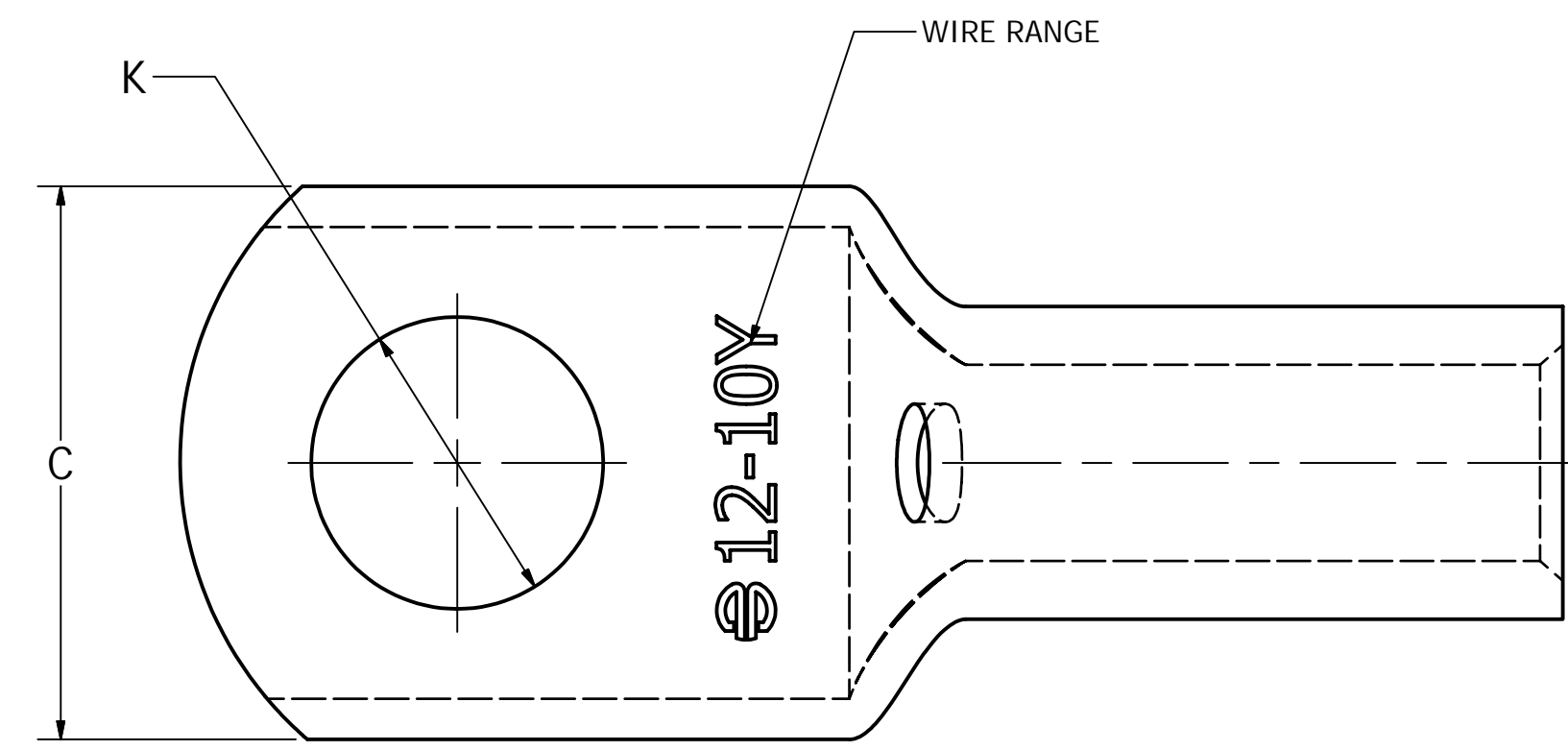
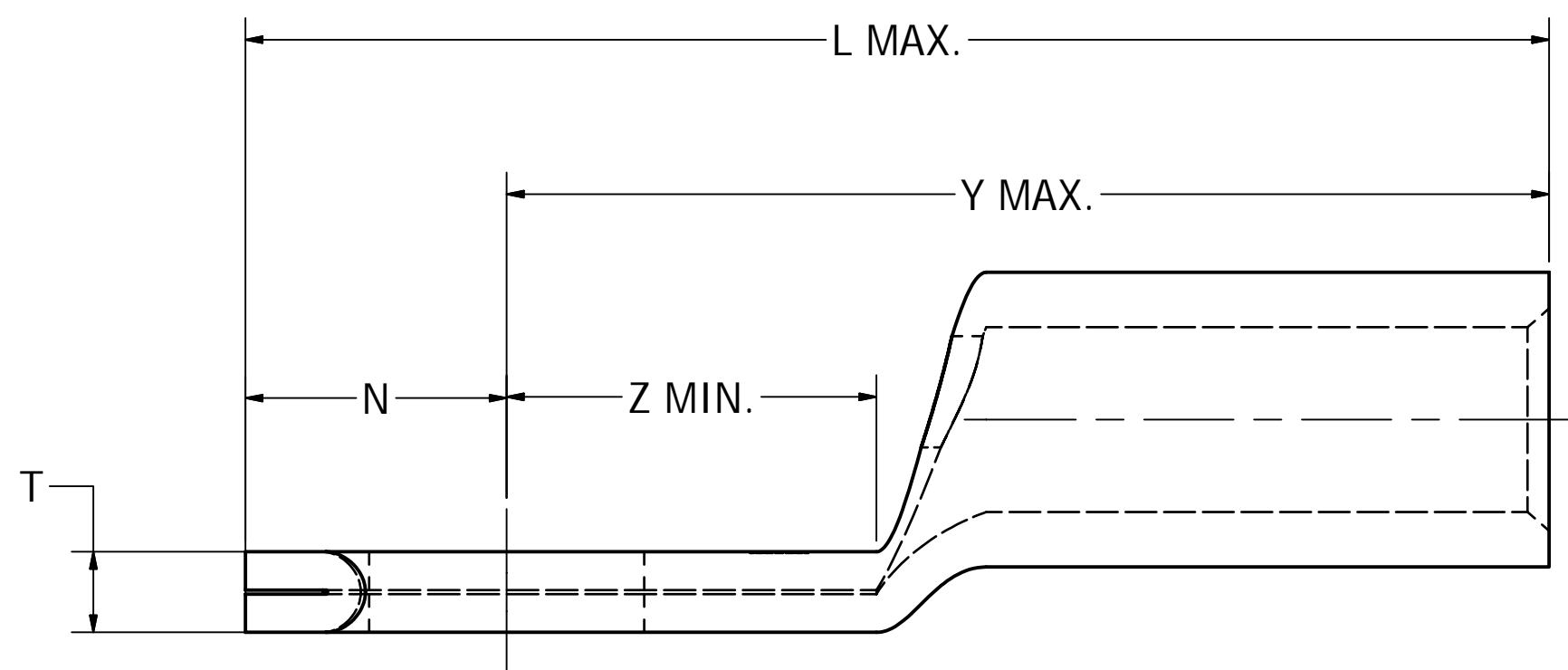

- NOTES:
1. TERMINAL: TIN PLATED COPPER
 2. DIMENSIONS IN BRACKETS [] ARE IN MILLIMETERS AND ARE FOR REFERENCE ONLY.
 3. DIE SETS ARE LISTED IN BRACKETS [] AFTER THEIR RESPECTIVE TOOLS.
 4. UL LISTED & CSA CERTIFIED WIRE CONNECTORS PER UL486A/B (FILE E9498) & CSA C22.2 NO. 65 REQUIREMENTS (FILE 42862)
 5. DISCONTINUED TOOLS: Y6NCP, Y10MRSA, Y10MRPA, EMR20, PATMD1022LI CONTACT TECH SERVICE FOR INFORMATION ABOUT APPROVED APPLICATIONS (1-800-451-4956)
 6. MEETS REQUIREMENTS OF SAE-AS7928 (MAIN OFFICE CAGE CODE NUMBER: 1NJK8)
 7. ADD "NK" SUFFIX FOR NICKEL PLATED HYLUGS FOR HIGH TEMPERATURE APPLICATIONS UP TO 650°F CONTINUOUS SERVICE AND 750°F INTERMITTENT SERVICE.
 8. ITEMS WITH CATALOG NUMBERS FOLLOWED BY ASTERISKS (*) ARE UL LISTED FOR SIZES 14-10 AWG ONLY WHEN INSTALLED WITH MR8G98 OR Y8MRB1 TOOLS.
- TOOLING IS NOT UL LISTED OR CSA CERTIFIED FOR TYPE YAV9.

TO ORDER BURNDY® PRODUCTS CALL		HYLUG™ (MULTI. PEEP HOLE)	
UNITED STATES 1-800-346-4175 (LONDONDERRY, NH)		ITEM NO: N/A	
CANADA: 1-800-361-6975 (QUEBEC) 1-800-387-6487 (ALL OTHER PROVINCES)		CAT. NO: YAV - (SEE TABLE)	
FOR PRODUCT INFO: http://www.burndy.com		DRAWN BY: R.BABU 11/08/2018	
		CHECKER: V.SAKTHIVEL 11/08/2018	
		DSN APRVL: K.CASTONGUAY 12/18/2018	
		MFG APRVL: --	
		QA APRVL: B.POST 12/06/2018	
		MKT APRVL: M.BAILLY 12/06/2018	
		PROD FAM: --	
		PROJECT #: --	
		SIZE: D	
		DOCUMENT TYPE: SALES	
		REL LEVEL: Released	
		DRAWING NO: 50094160	
		SHEET 1 OF 1	
		REV: A	