

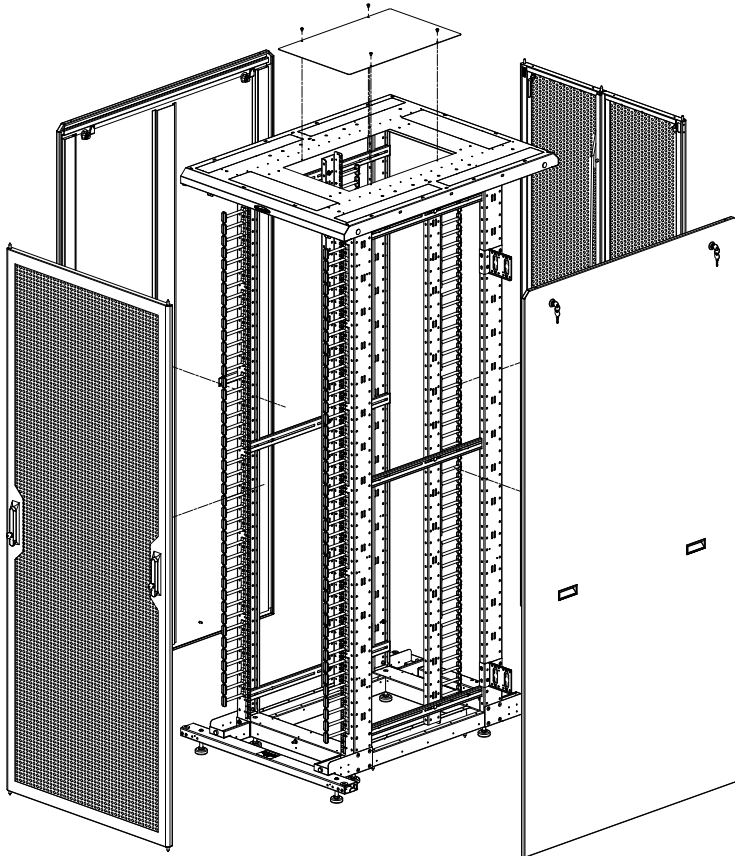

Invest in Solid Engineering

EN Series Enclosures Installation Instructions

(UL60950-1/UL2416 EN Series Equipment Cabinet/ Rack)



WeRackYourWorld.com

1-866-TRY-GLCC (879-4522)

Instructions for the following Great Lakes EN Enclosures:
GL910EN-4048, GL910EN-4042, GL910EN-3248, GL910EN-3242,
GL840EN-4048, GL840EN-4042, GL840EN-3248, GL840EN-3242,
GL780EN-4048, GL780EN-4042, GL780EN-3248, GL780EN-3242

PREFACE

This manual is provided to prevent service personnel from committing an act that results in the risk of fire, electric shock, or injury to persons. Only trained service personnel should receive, unpack, and assemble the Enhanced Networking Enclosure (UL60950-1 EN Series Equipment Cabinet/ Rack). In addition, only trained service personnel should install equipment in the EN Enclosures.

SAFETY SYMBOLS USED IN THIS MANUAL

This manual provides general safety guidelines to be observed during installation, operation, and maintenance of the EN Enclosure.



WARNING: Failure to follow directions in the warning could result in injury to persons or loss of life.



CAUTION: Failure to follow directions in the caution could result in damage to equipment or storage data.

SAFETY CONSIDERATIONS



WARNING: Improper handling and use of the EN Enclosure could result in equipment damage, serious injury, or possible death.

Only trained service personnel should be used to remove the Enclosure from the pallet. Also, be sure you have a sufficient number of service personnel. Do not attempt to move EN Enclosures by yourself.

Only UL® Listed ITE (Information Technology Equipment) units should be installed inside the EN Enclosures.

Be sure to read and follow all individual manufacturer equipment manuals for safety and installation instructions.

The EN Enclosure was not evaluated as a fire Enclosure.

Proper spacing is required when installing electrical equipment to avoid electrical shock. Maintain minimum spacing between the accessories and components and the computer Enclosure assembly for safe operation of the equipment when installed in accordance with the National Electric Code ANSI/NFPA 70-1999.

The ambient temperature operating range for the EN Enclosure and accessories is +50 to +95° F (+10 to +35° C).

The non-operating temperature is -4 to +140° F (-20 to +60° C).

SERVICE

The EN Enclosure should be repaired by personnel trained by Great Lakes, or returned to Great Lakes for repair or replacement. Contact Great Lakes Technical Support at 814.734.7303 or at werackyourworld.com

WHAT'S INCLUDED

- EN unit (assembled; including GR101EN Grounding Kit) with eight levelers
- Keys as needed (depending on configuration)
- (50) M6 cage nuts (3/8" square) and M6 screws or (50) #10-32 screws (depending on configuration)
- This user's manual

This user's manual applies to the following Great Lakes enclosures:

Part No.	H	W	D	RMU
GL910EN-4048	91	40	48	48
GL910EN-4042	91	40	42	48
GL910EN-3248	91	32	48	48
GL910EN-3242	91	32	42	48
GL840EN-4048	84	40	48	45
GL840EN-4042	84	40	42	45
GL840EN-3248	84	32	48	45
GL840EN-3242	84	32	42	45
GL780EN-4048	78	40	48	42
GL780EN-4042	78	40	42	42
GL780EN-3248	78	32	48	42
GL780EN-3242	78	32	42	42

Weight Capacity: 2000 lb.

EN ENCLOSURE FEATURES

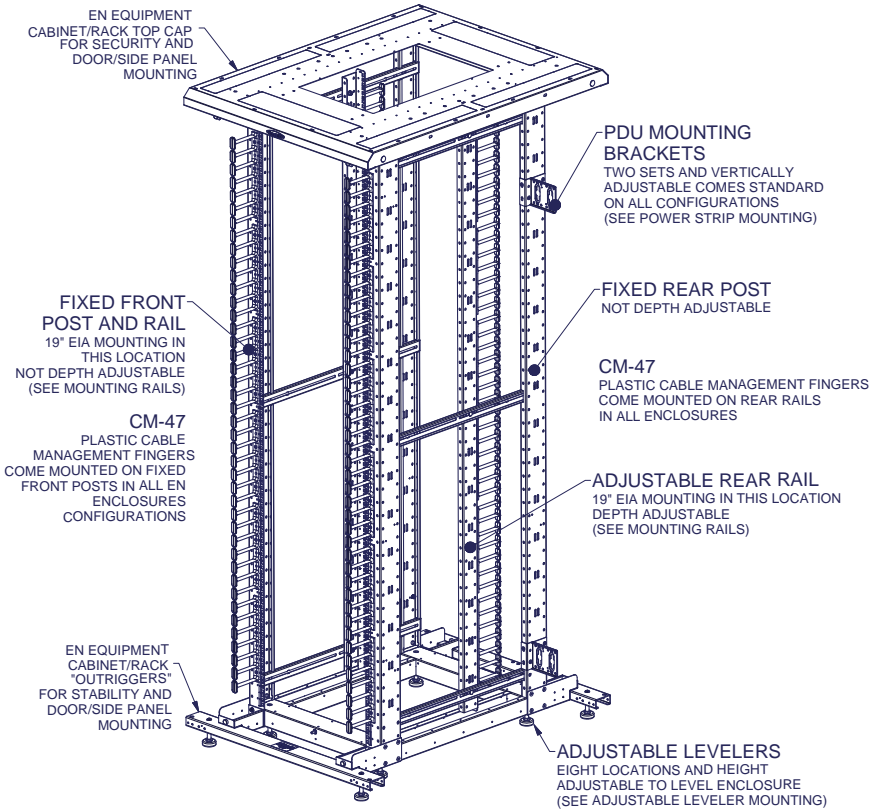

EN CONFIGURATIONS

All sizes of the EN Enclosures are available in three configurations: as a complete Enclosure, with doors only, and just a frame. Rails can be either tapped #10-32 or 3/8" sq. (M6)

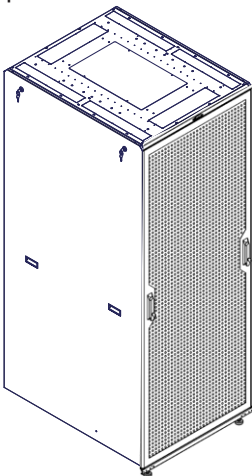

The GL840ENT-3242MSS (pictured) includes #10-32 rails with cable management fingers on all rails, 8 levelers, solid sides, solid top, mesh front door, split mesh rear door, and grounding kit.

EN CONFIGURATIONS (continued)

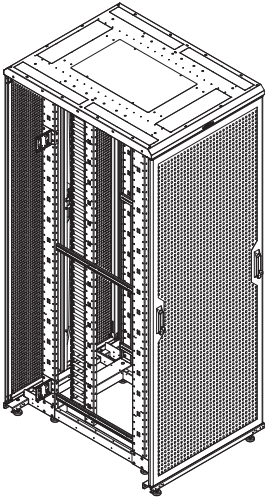

The GL840ENT-3242MSS-NS (pictured) includes #10-32 rails with cable management fingers on all rails, 8 levelers, solid top, mesh front door, split mesh rear door, and grounding kit.

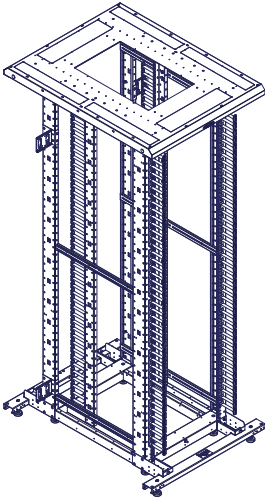

The GL840ENT-3242-FK (pictured) is an Enclosure frame (#10-32 rails with cable management fingers on all rails), 8 levelers, and grounding kit.

INSTALLATION

Receiving, Unpacking, and Removing the EN Enclosure from the Pallet

Inspect and report any damage before receiving. Unpack the EN Enclosure by carefully removing the corrugated carton and corners. Avoid damaging the EN Enclosure when removing packaging.



WARNING: Only trained service personnel should be used to remove the Enclosure from the pallet. Also, be sure you have a sufficient number of service personnel. Do not attempt to move the EN Enclosures by yourself.



WARNING: Be careful when moving Enclosures before installation. Sudden stops and starts, excessive force, obstructed routes, and uneven floor surfaces may cause the EN Enclosure to topple over.

Loading Equipment



WARNING: Only install equipment after the EN Enclosure has been properly secured. Do not move the EN Enclosure assembly while loaded.

Once in place at the desired/intended location, deploy the leveling feet for maximum stability.

Rated or maximum load capacity for the EN Enclosure is 2000 pounds on the floor or on leveling glides.

To maintain a uniform distribution of the mechanical load in the EN Enclosure, load the heaviest equipment first, at the bottom of the EN Enclosure and load the lighter units at the top.

OPERATING DOOR HANDLE

The door swing handles have been installed at the manufacturer. No additional assembly is required. To operate the swing handle, lift up at the bottom of the handle then swing the handle toward center of door to open. The handle must be kept in this position to close the door. Return the handle to the initial position and use the key provided to lock the handle. The lock on the side panels will accept the same key.

SINGLE MESH DOOR

The EN single mesh door comes with two swing handles; the door can open to the left or right. The rods running the length of the doors act as hinges when in the closed position. See ADJUSTABLE LEVELER MOUNTING (page 12) to adjust door latch function, if needed.



CAUTION: It is imperative that the door is closed and **LATCHED PROPERLY BEFORE** the opposite handle is turned to the open position. **AFTER CLOSING (AND BEFORE OPENING) ALWAYS** visually check to ensure the door is flush with the Enclosure at the **TOP** and **BOTTOM**. Only at this point can you turn the opposite handle.

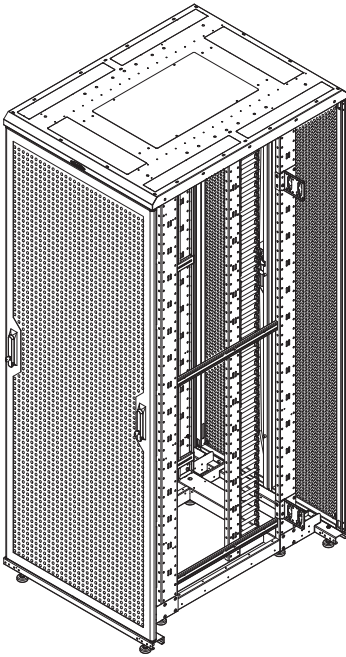

Door Shut; left and right handles completely latched closed

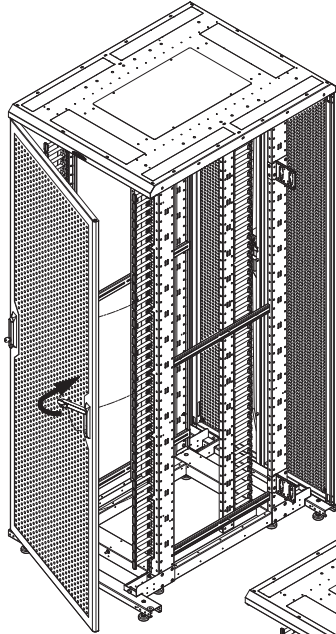

Door Opened with right handle; left handle completely latched closed

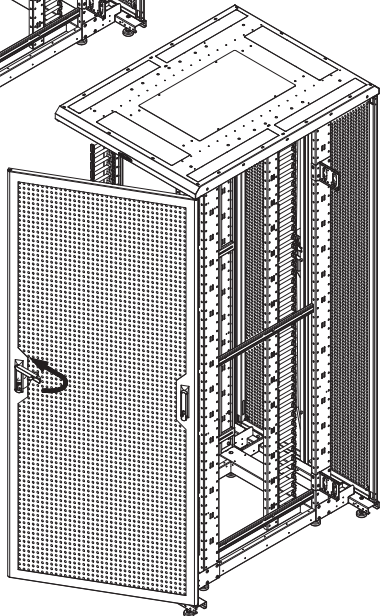

Door Opened with left handle; right handle completely latched closed

SINGLE MESH DOOR: REMOVAL



CAUTION: Unplug the quick-disconnect end of the bonding jumper wire from the mesh door prior to removing the mesh door. Be cautious and use both hands when removing all EN doors and side panels.

1. Place one hand in the center top of door and hold tightly.
2. Turn both handles to the open position (This disengages the rods from the EN Enclosure that act as both the hinges and latches for the door).
3. The door will now be held in place by only your hand. Slowly allow the door to fall towards you and lift to remove.



CAUTION:
To prevent damage to the handle and rods, leave handles in the open position at all times when the door is not installed.

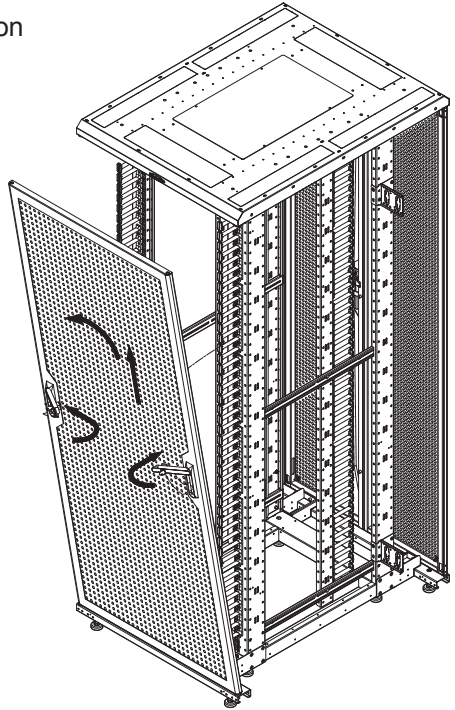

SINGLE MESH DOOR: REINSTALLATION

1. Ensure that both swing handles have remained and are still in the open position.
2. Confirm the shoulder washers have remained and are in the top and bottom frame of the EN Enclosure.
3. Lift the door and gently rest the center of door on your foot. Swing both handles to the closed position. Ensure the weight of the door does not rest on the rods that protrude out of the bottom of the door.
4. Lift the door with both hands. Align the rods (one on each side of door) protruding from the bottom of the door and insert them through the shoulder washers in the base of the frame.

5. The door should still be unattached at the top of the EN Equipment Cabinet/Rack and will pivot at the base of the door slightly. Put one hand in the top center of the door. With your free hand, turn one handle to the open position. Gently push the door inward.
6. Slowly engage that same handle back into the closed position.
7. Check to make sure that half of the door is flush with the EN Equipment Cabinet/Rack on both the **TOP AND BOTTOM**.
8. You can now open the opposite handle completely and the door will function properly. Close the opposite side normally. Reconnect the quick-disconnect end of the bonding jumper wire to electrically bond the side panel to the base of the EN Enclosure.

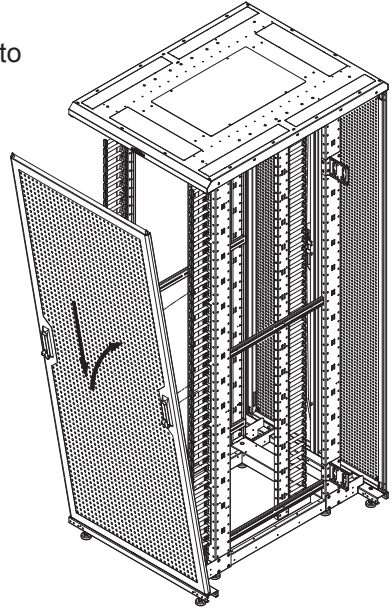

SINGLE & SPLIT DOORS: FRONT/REAR MOUNTING

Split mesh doors can be mounted on the front or rear of any EN series Enclosure and are standard on 40"W EN Enclosures. Single mesh doors can be mounted on front or rear of 32"W EN Enclosures only.

All doors mount on shoulder washers. Each door, if ordered separately, will come with corresponding shoulder washers (see drawings below). If doors come installed on the EN Enclosure and you wish to move the location of the doors, the shoulder washers must be moved **WITH** the door.

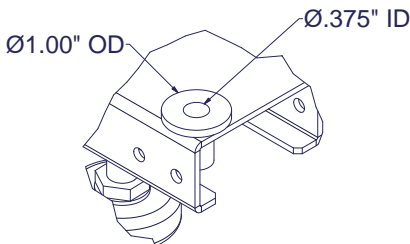

ASSOCIATED SHOULDER WASHER
FOR **SINGLE** MESH DOOR

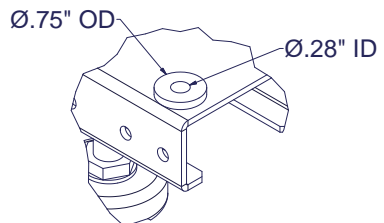

ASSOCIATED SHOULDER WASHER
FOR **SPLIT** MESH DOOR

SPLIT MESH DOOR REMOVAL/INSTALLATION



CAUTION: Unplug the quick-disconnect end of the bonding jumper wire from the mesh door prior to removing the mesh door. Use both hands when removing all EN doors and side panels.

1. Use swing handle to open both doors. Doors now hinge at the top and base on "pins."
2. Using one hand, hold the door in the center and disengage the top pin by squeezing it downward.
3. Allow the door to slightly fall forward. Gently lift the door out of its washer.
4. Set the door aside and repeat the procedure for the second door.



CAUTION: To prevent damage to the handle and rods, keep them in the open position at all times when the door is not installed.

5. To reinstall, reverse the process.
6. Reconnect the quick-disconnect end of the bonding jumper wire to electrically bond the mesh door to the base of the EN Enclosure.

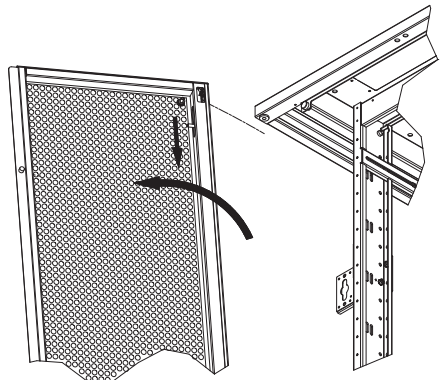
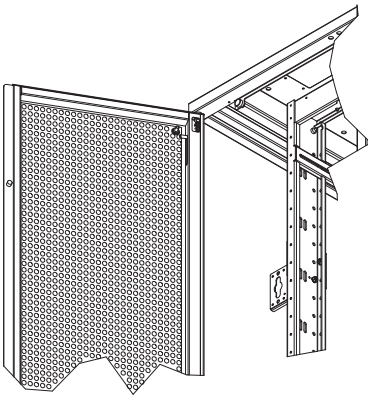

SIDE PANEL REMOVAL/REINSTALLATION



CAUTION: Unplug the quick-disconnect end of the bonding jumper wire from the side panel prior to removing the side panel. The side panels are secured to the EN Enclosure with two quarter turn, keyed locks. Use both hands when removing all EN doors and side panels.

To remove the side panel, be sure to support the panel with one hand, then use provided keys to turn both locks. Tilt the top of the side panel out slightly and lift the panel until it is free. To install the side panel, reverse the process. Make sure slots on the side panel engage with the two tabs at the bottom of the frame. For ease, insert the key into at least one lock before lifting the panel and aligning onto tabs at base. Once installed, lock side panel in place. Reconnect the quick-disconnect end of the bonding jumper wire to electrically bond the side panel to the base of the EN Enclosure.

If you wish to install a side panel in a new location, be sure that the side panel catch brackets that are mounted to the outriggers of the EN Enclosure move with the side panel to the new desired location. Side panel catch brackets are held into place with four #10-32 screws.



DO NOT transport an enclosure with casters while side panels are installed.

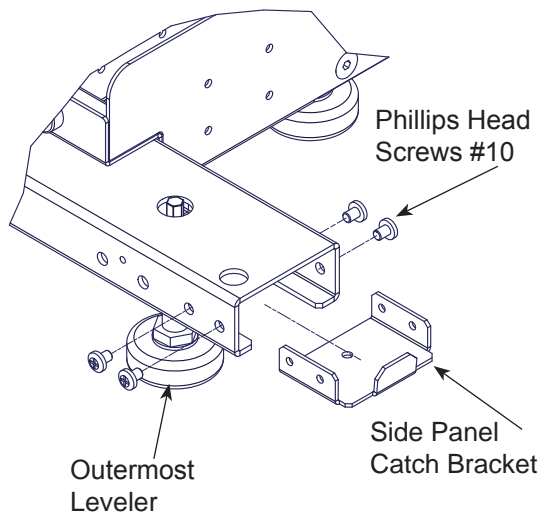
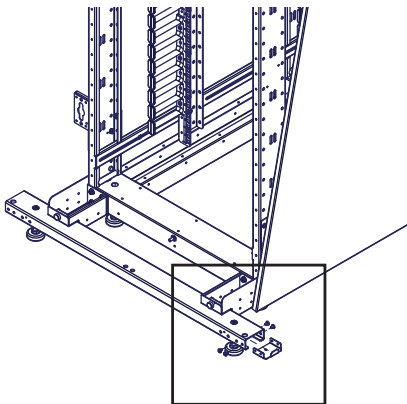

ADJUSTABLE LEVELER MOUNTING

On the bottom of the cabinet there are eight threaded holes, four in the outermost corners and four under the main vertical support posts, behind the EIA mounting of the EN Enclosure. All are threaded 1/2-13 thds. All eight levelers will come installed. The cabinet level can be adjusted with the use of a 3/4" open-end wrench or a 5/16" closed wrench or socket from inside of the EN Enclosure.



CAUTION: The four innermost levelers, under the main vertical support posts, must contact the floor and be adjusted to ensure the cabinet/rack is level and square prior to adjusting the four outermost levelers. Single mesh door adjustment can be done by raising or lowering the outermost levelers only. Do not overextend the leveling glides past 3". This could remove the leveling glide completely causing the EN Enclosure to be unstable. (It is suggested to tip EN Enclosure over if desired to avoid this risk.)

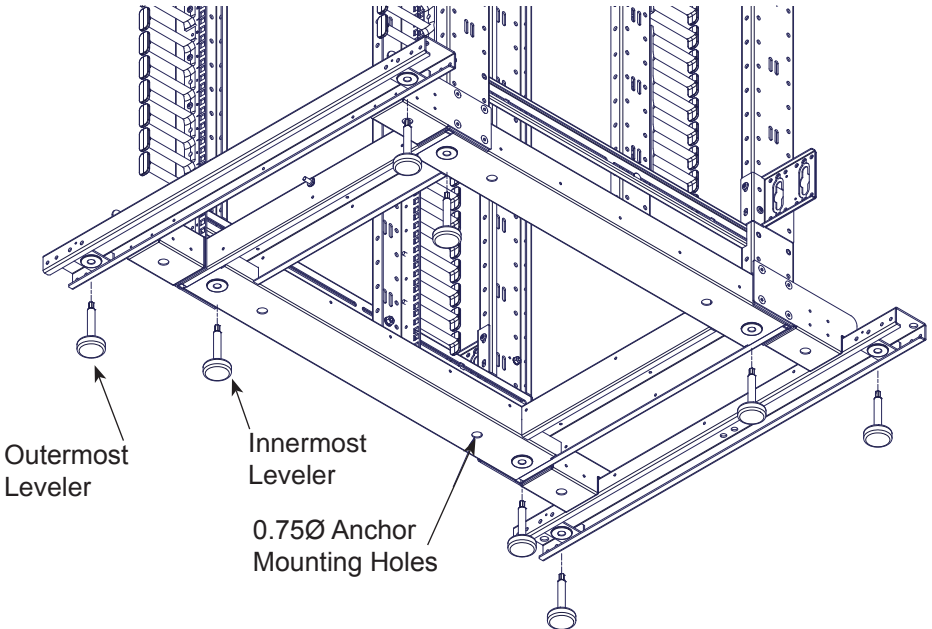

ANCHOR MOUNTING THRU HOLE

The middle .75 dia. thru holes (the same holes used to bolt the EN Enclosure to the pallet) are for securing the EN Enclosure to the floor.

TOP PANEL MOUNTING

Removing the top panel kit can be done by removing the four #10-32 x 1/2" lag screws. Then simply lift the top panel off. There are 6 top panel options for the EN Enclosures:

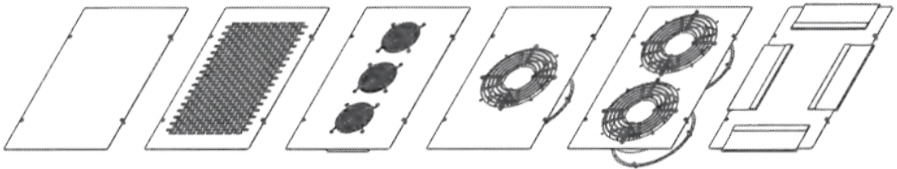
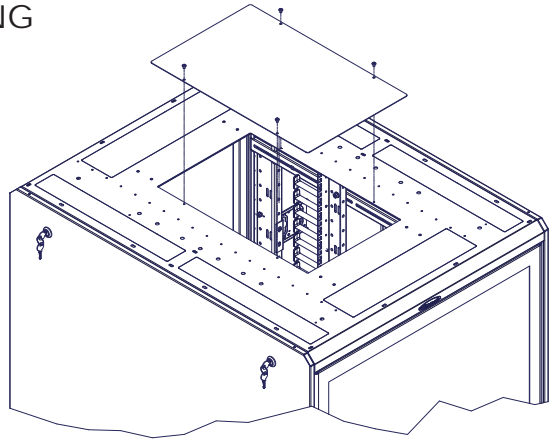

TPEN-S
Solid

TPEN-P
Perforated

TPEN-F
Three, 75
CFM Fans

TPEN-F10
One, 10" 550
CFM Fan

TPEN-2F10
Two, 10" 550
CFM Fans

TPEN-B
Brush
Grommet

MOUNTING RAIL KITS

Each EN Enclosure has two pair of 12 gauge powder coated vertical mounting rails (19" EIA 310-E Compliant). Universal cage nut rails (M6, 3/8" square) and tapped #10-32 rails are available.

RAIL ADJUSTMENT

Front EN rails are fixed at a depth of 6.5" (42"D EN) or 8" (48"D EN). Rear rails are attached using 1/4-20 carriage bolts and 1/4-20 hex nuts with serrated flange. By loosening the top, middle and bottom bolts using a 3/8" socket set, the rails can be adjusted infinitely front to back. Rack Mount Units (RMU) are marked on all rails for easy equipment mounting. Flexible Mounting Profile (FMP) holes and vertical cable tie down slots can be found on all rails.

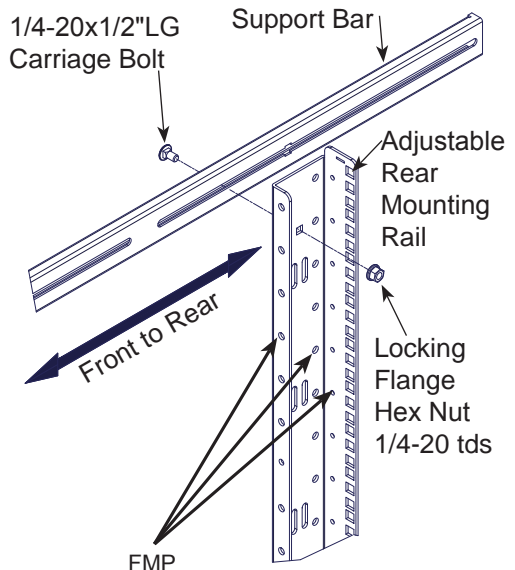

POWER STRIP MOUNTING KIT

For your convenience, we have provided mounting brackets on the left and right rear posts of the EN Enclosure for vertical mounting of power strips. These brackets allow you to mount a PDU with button mounting at a variety of spacings. Diamonds in posts indicate 44" & 61.25" center to center mounting (See drawing). Typically, any power strip shipped with an EN Enclosure will come installed by the manufacturer. If no power strip has been ordered with the Enclosure, brackets will come standard at 61.25" spacing. To adjust Universal Power Strip Brackets in an EN Enclosure, measure the required mounting distance top to bottom, install brackets, then install power strip. Brackets will be held onto posts in 2 or 3 mounting locations with M6 hardware (M6-1 x 12mm Phillips head screws and M6-1 keps style locknuts).



POWER

When using power distribution units (PDUs), each PDU should be connected to a committed branch circuit that is rated for the continuous load of all the equipment connected. When not using a PDU, each piece of equipment should be connected to a dedicated branch circuit.

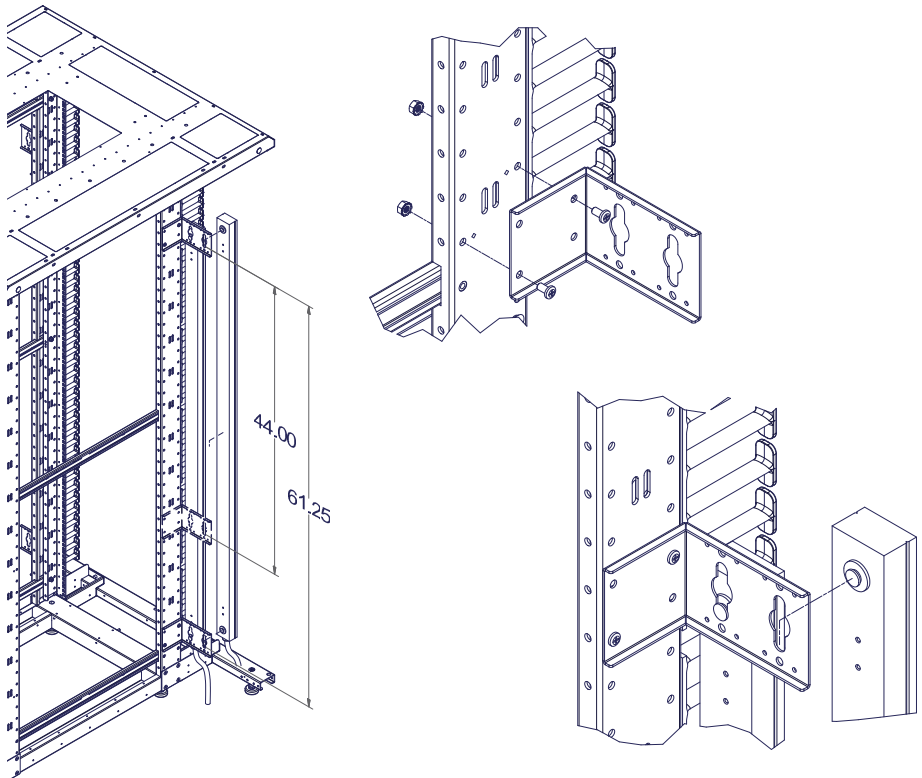

PLASTIC CABLE MANAGEMENT FINGER KITS, CM-47, ENC-K24, & ESC-K12

All EN Enclosures come standard with one ENC-K24 kit; this kit consists of 24, CM-47 plastic cable management fingers (7 RMU). The kit will come fully installed (using threaded screws) on the face of all four vertical posts of the EN Enclosure. Additional ENC-K24 kits, or single CM-47 fingers can also be ordered. Additional kits will come with threaded screws and plastic rivets. Mounting location of fingers will determine whether screws or rivets are used. It is recommended that each CM-47 be installed using 3 points of attachment.

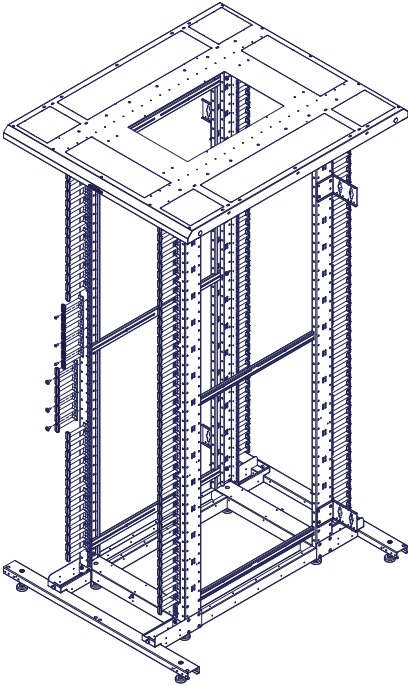

These fingers can be moved and configured to many different locations to achieve a number of cable management uses.

COMES STANDARD INSTALLED WITH #12-24 x 1/2" L SELF TAPPING SCREWS IN TAPPED HOLES

TOOL-LESS PLASTIC RIVETS IN OTHER FLEXIBLE MOUNTING PROFILE LOCATIONS IN Ø0.25 THROUGH HOLES

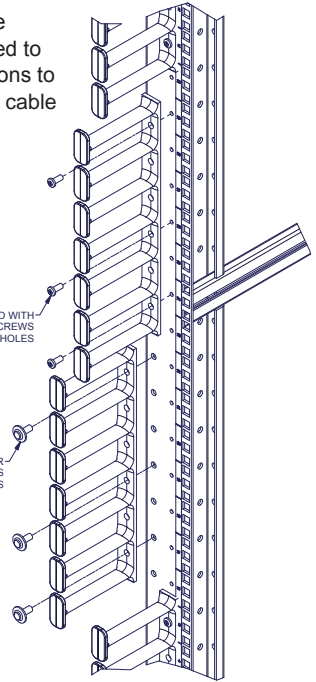

CM-47 VERTICAL CABLE MANAGER KIT

A vertical cable manager can be created with six additional finger sections installed on the SIDE of the vertical posts (toward side panel). The ESC-K12 is a kit of 12 CM-47s and has enough sections to create 2 vertical cable managers.

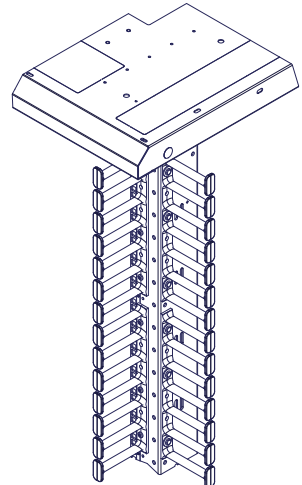

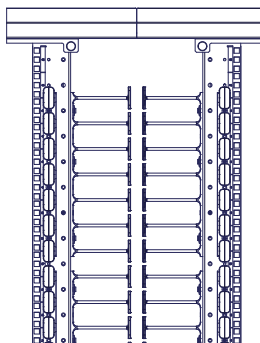
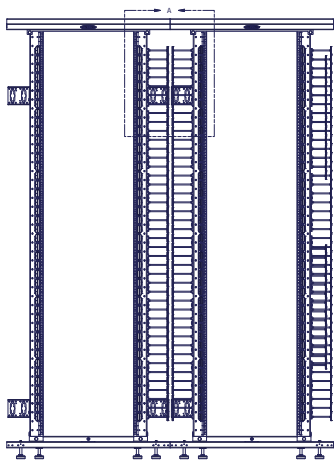

Mount 2 vertical cable managers toward one another in ganged EN Enclosures for a large intra-cabinet vertical cable trough.

HORIZONTAL CABLE MANAGER KIT

The Horizontal Cable Manager routes cables from the front to the rear of the Enclosure. The manager is installed using 3, tool-less plastic rivets on each side of the manager. For 42"W EN Enclosures, use the HCM-EN42; for 48"W Enclosures, use the HCM-EN48.

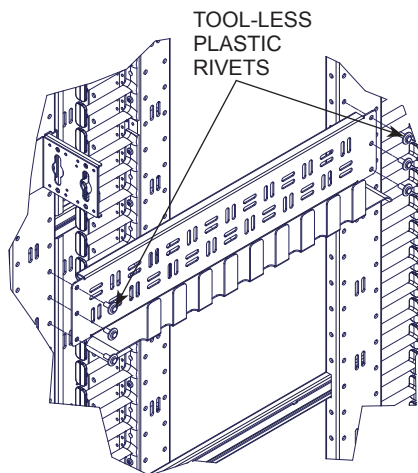

OVERHEAD CABLE TROUGH KIT

When ordered with the EN Enclosure, the overhead cable trough ships assembled, but not installed. The top of the EN Enclosure has a variety of mounting holes. Place the trough where you require cable routing. For 32"W EN Enclosures, use the TCT32; for 40"W Enclosures, use the TCT40.

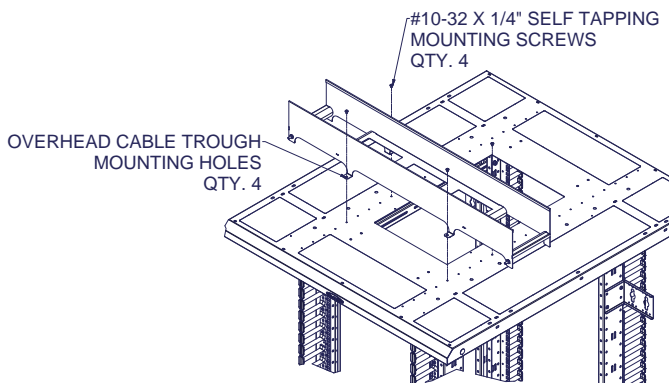

LADDER RACK BRACKET KIT

All tops have pre-drilled cable runway attachment holes to install ladder rack brackets.

Each ladder rack bracket part number is a single ladder rack bracket with installation hardware; two brackets are required per enclosure. Once two brackets are installed, ladder rack can be attached. Height adjustable brackets can be used when different height enclosures require ladder rack across them. Fixed height brackets can be used when all enclosures in a row are the same height (detail shows fixed height bracket installed).

Available ladder rack brackets include:

- LRB-12A1 Single Height Adjustable Bracket (6.5"-11.5") to support 12"W ladder rack;
- LRB-12A2 Single Height Adjustable Bracket (14"-24") to support 12"W ladder rack
- LRB-24A1 Single Height Adjustable Bracket (6.5"-11.5") to support 12-24"W ladder rack
- LRB-24A2 Single Height Adjustable Bracket (14"-24") to support 12-24"W ladder rack
- LRB-12 Single Fixed Height Bracket (3") to support 12"W ladder rack
- LRB-24 Single Fixed Height Bracket (3") to support 12-24"W ladder rack

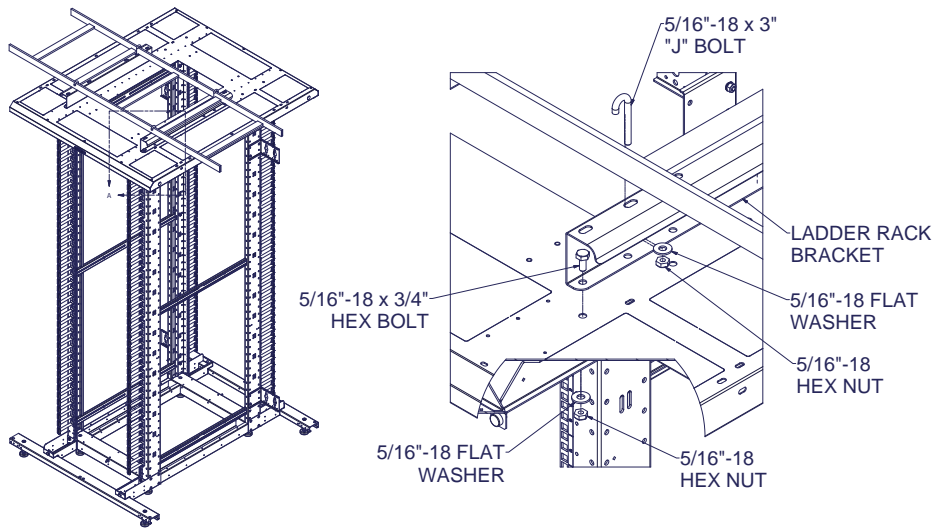

ZERO RMU MOUNTING, ZR1 & ZR2 KITS

Both ZR bracket kits fit on the 32"W & 40"W EN Enclosures. These allow for "0" RMU mounting of 19" rack mount power strip units or other 1 or 2 RMU equipment (such as patch panels). Install the bracket onto the rail or post toward the side panel. It is important to ensure you have 18.3" between the inner holes for 19" mounting.

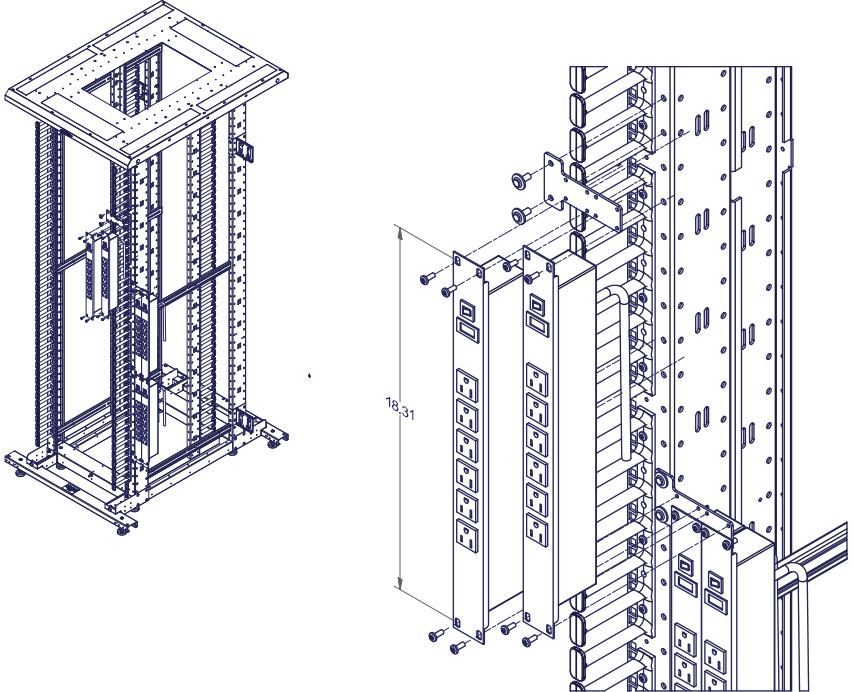

CASTER MOUNTING



CAUTION:

To install casters or levelers, the enclosure may need to be tipped onto its side. The enclosure can be very heavy, several people will be required in this process. Please practice safe lifting techniques. REMOVE ALL doors and sides prior to tipping the enclosure on its side to prevent damage.

1. In each 7208EN Caster kit, there are four plate casters with mounting brackets pre-installed. All caster bracket assemblies are identical.
2. To install casters without tipping enclosure on its side, all eight leveling glides must be extended to lift the enclosure at least 2.25" off the floor. See Adjustable Leveler Mounting for information.

CASTER MOUNTING (continued)



CAUTION : Do not overextend the leveling glides past 3" total height. This could remove the leveling glide completely causing the enclosure to be unstable. (Tip enclosure over if desired to avoid this risk)

3. In the bottom corner of each enclosure, on the left and right side of the main support posts, there are four 1/4-20 flat head bolts.
4. One corner at a time, use an allen wrench to loosen or remove the two BOTTOM 1/4-20 flat head bolts. Do not loosen or remove remaining two TOP 1/4-20 bolts.
5. Locate notches in the bottom of each caster bracket assembly, slide these notches over the existing 1/4-20 bolts or replace the bolts with two flanged head bolts (included), if preferred.
6. Install four remaining 1/4-20 flanged head bolts on the top of the caster bracket assembly to the posts. Top two bolts will thread into existing threads in post. Middle bolts should be secured with included 1/4-20 flange head nuts on opposite side of post, inside EIA.
7. Repeat steps 4 through 6 for the three remaining casters.
8. After all four casters have been installed, and enclosure is in desired location, adjust levelers to floor to reduce movement.



DO NOT transport an enclosure with casters while side panels are installed.

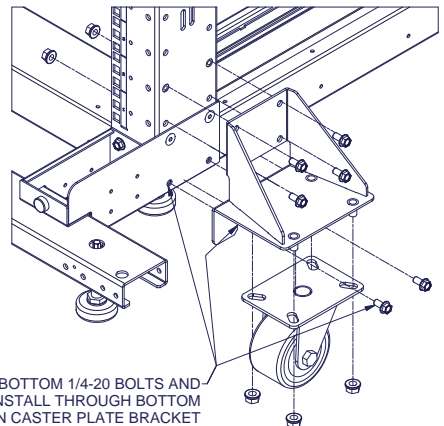
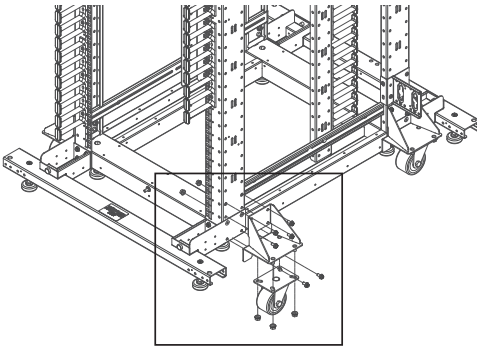

NETWORKING/GANGING KIT

EN Enclosures can be networked to each other using the G101EN Networking/Ganging Kit. EN Enclosures can be networked to Great Lakes ES Cabinet/Racks using the G101EN2ES Networking/Ganging Kit.

Enclosures can be ganged together without side panels installed, or with a single side panel between two enclosures.

When ganging enclosures without side panels, remove two plastic plugs from the top of each enclosure frame (one plug towards the front of the frame, one towards the rear of the frame). Two side panel catch brackets at the bottom of each enclosure frame must also be removed. Align the networking thru holes with both enclosures facing the same location; ensure that enclosures are level (See "Adjustable Leveler Mounting") . Install ganging hardware, as shown in Detail A.

When ganging enclosure with a single side panel, remove two plastic plugs from the top of each enclosure frame and from the side panel. Remove two side panel catch brackets from the enclosure without side panels. Align the networking thru holes with both enclosures facing the same direction; ensure that enclosures are level (See "Adjustable Leveler Mounting") . Install ganging hardware as shown in Detail B.

Note: The same hardware pack is used for ganging enclosure without side panels or with a single side panel. The necessary hardware for each option varies; there will be leftover hardware.

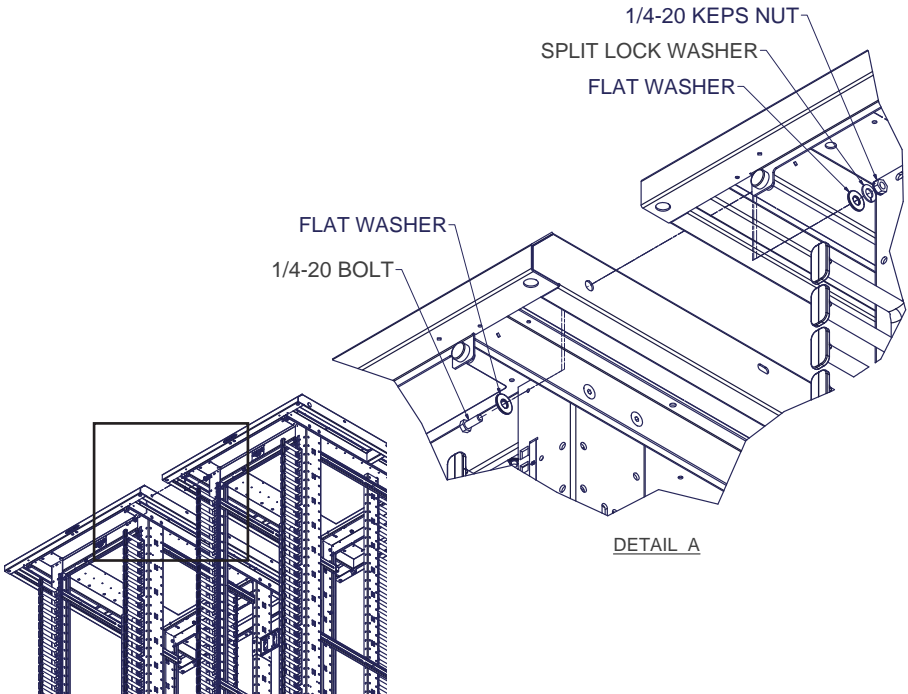

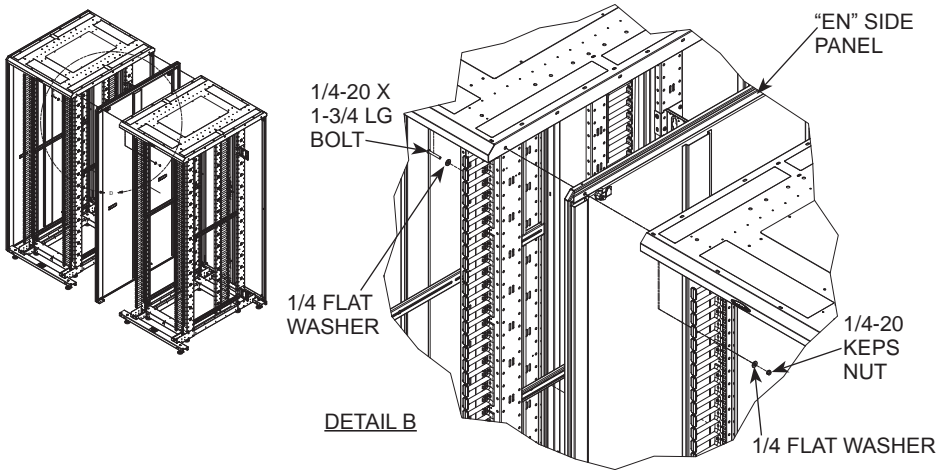

PROTECTIVE GROUNDING

Protective grounding studs are provided along with grounding quick disconnect jumper wires that electrically bond the EN Enclosure doors to the EN Enclosure frame.



WARNING: To avoid injury to persons or loss of life, ground each EN Enclosure individually to the dedicated branch circuit ground.

CONNECTING MAIN PROTECTIVE GROUNDING STUD TO THE DEDICATED BRANCH CIRCUIT GROUND

Connect the dedicated branch circuit ground connector to the main protective grounding stud located inside at the bottom rear of the EN Enclosure frame using a listed ring or closed-loop terminal.

CONNECTING MAIN PROTECTIVE GROUNDING STUD TO THE PROTECTIVE BONDING CONDUCTORS

Connect the rear doors to the main protective grounding studs located inside at the bottom and top rear of the EN Enclosure chassis using a listed ring or closed-loop terminal. Connect the front door to the grounding stud located inside at the bottom front of the EN Enclosure frame using a listed ring or closed-loop terminal.

PARTS NOT BONDED TO PROTECTIVE EARTHING TERMINAL

The following parts are not effectively bonded to the protective earthing terminal: rails and front to back rail horizontals. If these parts need to be bonded to the protective earthing terminal, do so in accordance with Article 250 of the National Electric Code.

BAFFLE KITS

Baffle Kits create proper airflow for switches and side-to-side airflow equipment, as suggested by manufacturers such as CISCO. Cool air is channeled into the equipment along the right side and exhaust air is directed out along the left side of the equipment. Kits are tool-less and easily attach to rails outside of the EIA mounting profile. Kits are unique to EN and ES Enclosures, creating the perfect fit between switch and EN Enclosure.

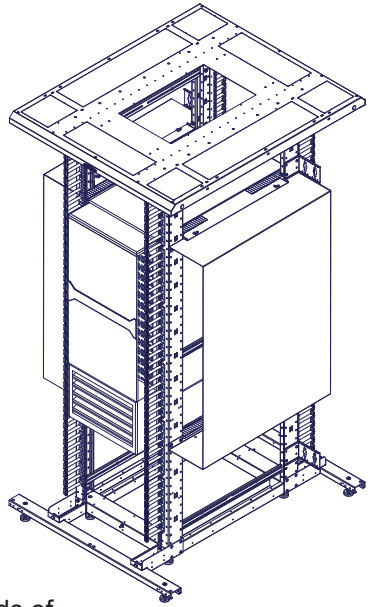

ENCLOSURES FOR BAFFLE KITS: EN & ES ENCLOSURES

EN Enclosures are designed specifically to support high-density cable management needs of switch and network application. ES Enclosures are ideal for servers where cable management, cooling, and power are a necessity.

	Recommended Great Lakes Enclosure		Great Lakes Baffle Kit Part No.	
	EN Series Enclosure	ES Series Enclosure	EN Baffle Kit	ES Baffle Kit
7000 Series				
7018 ¹	40"W x 48"D	N/A	ENSAB25	N/A
7010 ²	32/40"W x 48"D	30"W x 48"D	N/A	N/A
7009	40"W x 48"D	N/A	ENSAB14A	N/A
7004 ³	40"W x 48"D	N/A	ENSAB7A	N/A
9500 Series				
9513	32"W x 42/48"D	30"W x 42/48"D	ENSAB14D	ESSAB14D
9509 ⁴	32"W x 42/48"D	30"W x 42/48"D	ENSAB14	ESSAB14
6500 Series				
6513(-E)	32"W x 42/48"D	30"W x 42/48"D	ENSAB19	ESSAB19
6509(-E)	32"W x 42/48"D	30"W x 42/48"D	ENSAB14	ESSAB14
6506(-E)	32"W x 42/48"D	30"W x 42/48"D	ENSAB11	ESSAB11

¹ Four post mounting is required with a rail placement of 24". ² The 7010 has front to rear airflow; no left or right side clearance is required; when installed in a cabinet, 5.00" rear clearance is required

CHOOSING YOUR BAFFLE KIT & ENCLOSURE

Based on your switch/equipment, choose the appropriate EN or ES Enclosure. Take into consideration your cable management, cooling, and power needs; each EN Enclosure addresses these needs in different ways. Baffle Kit part numbers are specific to EN or ES Enclosures.

The chart below shows which kits accommodate various CISCO switches. Other brands of side-to-side airflow equipment can also be mounted. To determine the correct EN Enclosure and baffle kit, compare physical equipment dimensions to what is listed.

For detailed instructions on how to install your baffle kit, please refer to the instructions provided with your baffle kit. These instructions are also available at werackyourworld.com

Although equipment may physically fit into a Great Lakes EN Enclosure, with or without brackets, customers must also review and comply with the equipment manufacturer's installation and other requirements. For example, the E and ES Series Enclosures, when in an open frame configuration, can physically support the installation of a Cisco 7018 Series switch; however, the E and ES Series Enclosure frame designs do not provide the airflow space clearance required by Cisco.

Great Lakes' EN (Enhanced Networking) Series of EN Enclosures is designed to support the installation of Cisco switches and other side-to-side airflow equipment. The EN Series has the airflow space clearances that are currently required and has accessories (including baffle kits) that are designed to support proper operational conditions. For more information, please call 1-866-TRY-GLCC.

When any equipment or accessory is installed in a Great Lakes product, the installation procedures, recommendations and product warranty requirements of the equipment manufacturer must be followed. Great Lakes will not be responsible for any losses or claims arising from a customer's installation of electrical, electronic or other third party products in any Great Lakes Enclosure, unless caused solely by a written configuration prepared by Great Lakes for that customer or by a configuration provided by Great Lakes' website, any configuration relies on complete and accurate information from the customer.

CISCO Equipment Dimensions		CISCO Recommended Clearances		
		Cabinet Installation	Rack Installation (No Side Panels)	
RMU	Depth	Distance from chassis to inside of cabinet	Distance between racks	Distance from chassis to wall
25	33.1"	11.00"	6.00"	11.00"
21	33.1"	N/A	N/A	N/A
14	24.10"	11.00"	6.00"	11.00"
7	24.00"	11.00"	6.00"	11.00"
14	28.00"	6.00"	12.00"	6.00"
14	18.40"	2.50"	6.00"	2.50"
19	18.10"	6.00"	12.00"	6.00"
14	18.10"	6.00"	12.00"	6.00"
11	18.10"	6.00"	12.00"	6.00"

³ The 7004 requires 11.00" clearance on the right side only; exhaust exits from the rear, no rear clearance required. ⁴An additional 0.75" of height is required for rail mount brackets; brackets can be removed after chassis is installed. NOTE: It is important to read and understand CISCO installation guides that are associated with each switch.

GREAT LAKES
CASE & CABINET



Invest in Solid Engineering

Thank you for your business!

*weRack
your
World!*™



REACH
COMPLIANT



ETSI Associate Member

FORM: #MS - 5.02-24, REV #3