

CONFIG PART #

910ENT3248MSS

EN FRAME 91"H x 32"W x 48"D WITH 2 PAIR OF 48 RMU #10-32 TAPPED RAILS, CABLE MANAGEMENT FINGERS ON ALL RAILS, SOLID TOP, DUAL HINGE PERF FRONT DOOR, SPLIT PERF REAR DOOR AND SOLID SIDES

910EN3248MSS

EN FRAME 91"H x 32"W x 48"D WITH 2 PAIR OF 48 RMU M6 RAILS, CABLE MANAGEMENT FINGERS ON ALL RAILS, SOLID TOP, DUAL HINGE PERF FRONT DOOR, SPLIT PERF REAR DOOR AND SOLID SIDES

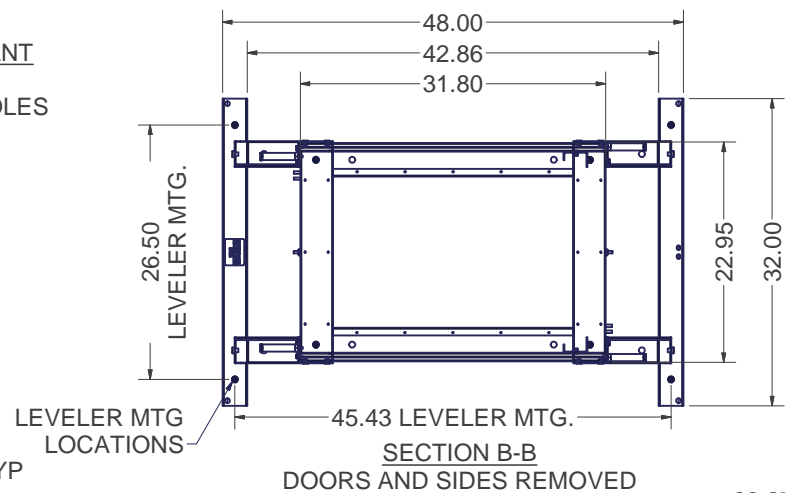
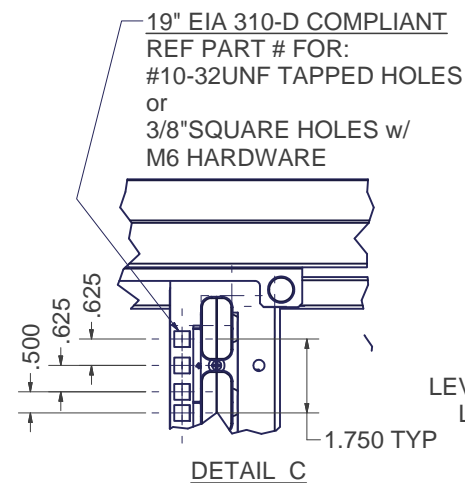

INDEPENDENT MOUNTING LOCATIONS FOR LADDER RACK BRACKETS OR TOP MOUNTED CABLE TROUGHS

- TOP PANEL OPENING (273 sq.in.) SOLID, VENTED, OR w/ EXHAUST FANS FOR UP TO 1100 CFM
- 5.75 x 17.25 CABLE PASS THROUGH KNOCKOUT (99.2 sq.in.), 2 PLACES
- 2.63 x 7.25 CABLE PASS THROUGH KNOCKOUTS (19.1 sq.in.), 4 PLACES
- 2.63 x 27.00 CABLE PASS THROUGH KNOCKOUTS (71 sq.in.), 2 PLACES

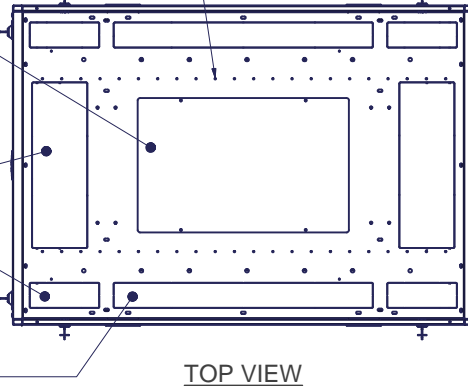

SPLIT MESH REAR DOORS PART # 9102EN32SM

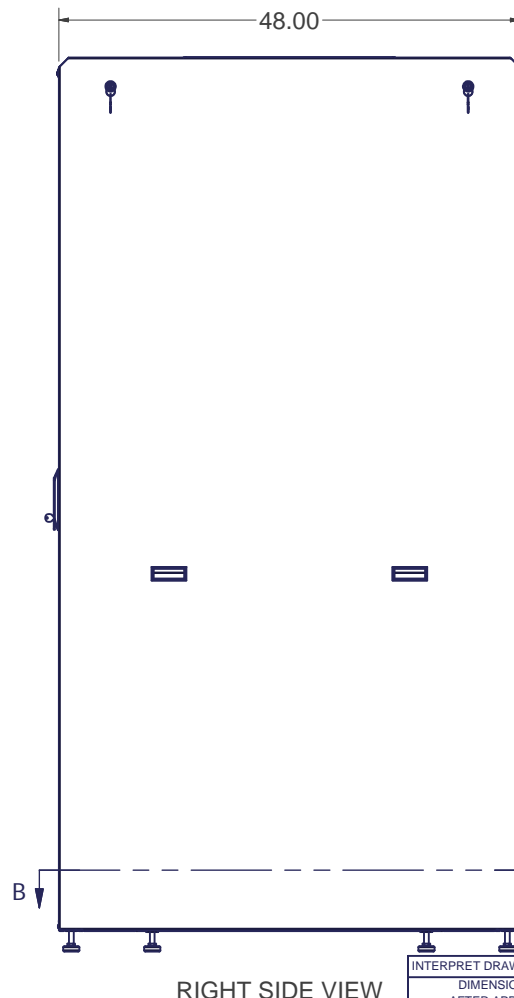
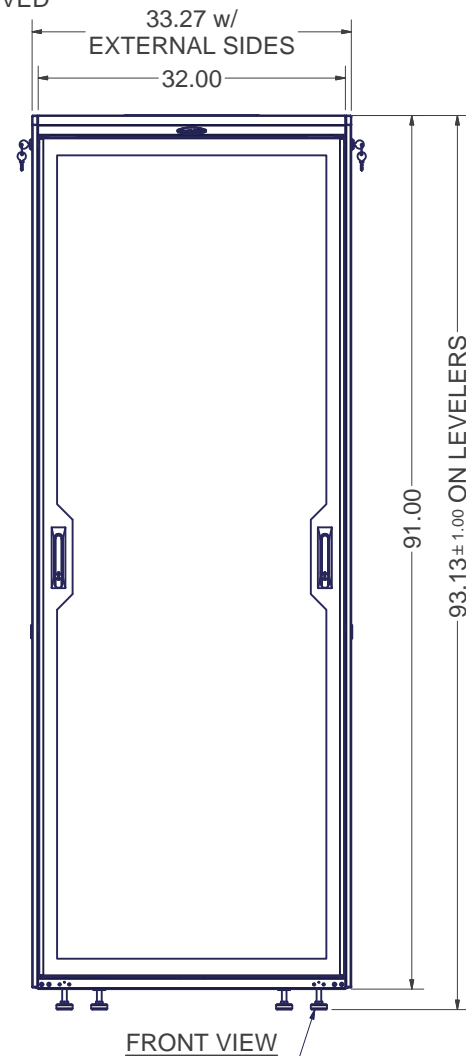
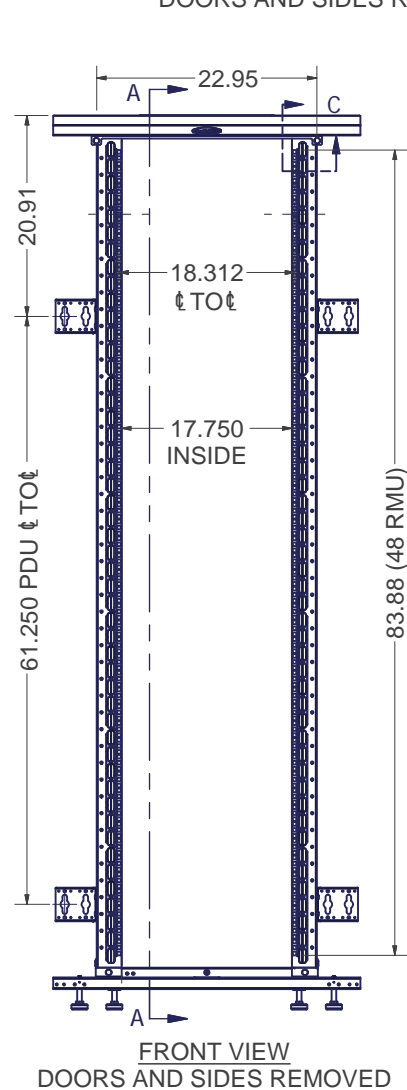
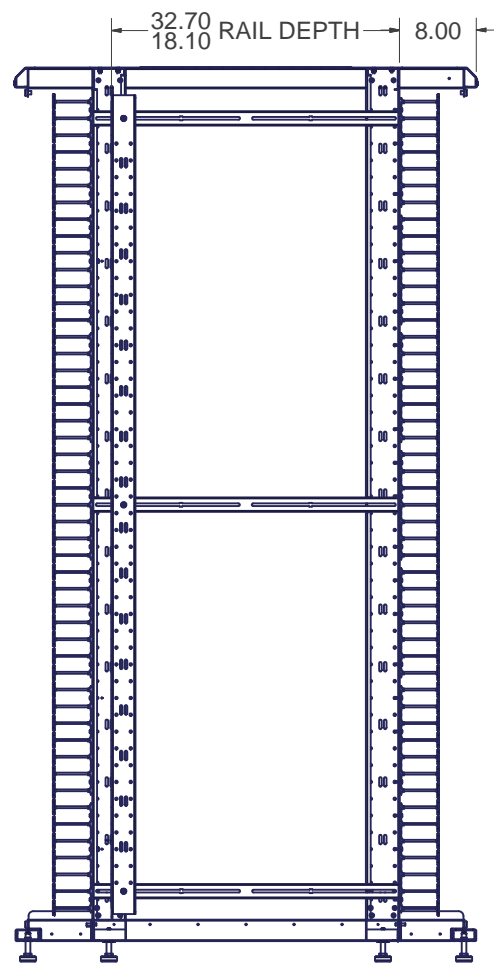
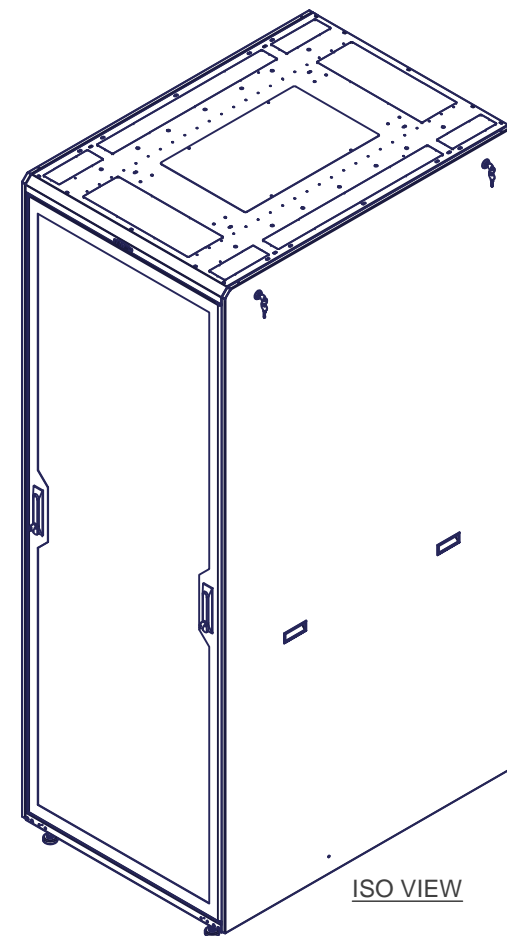
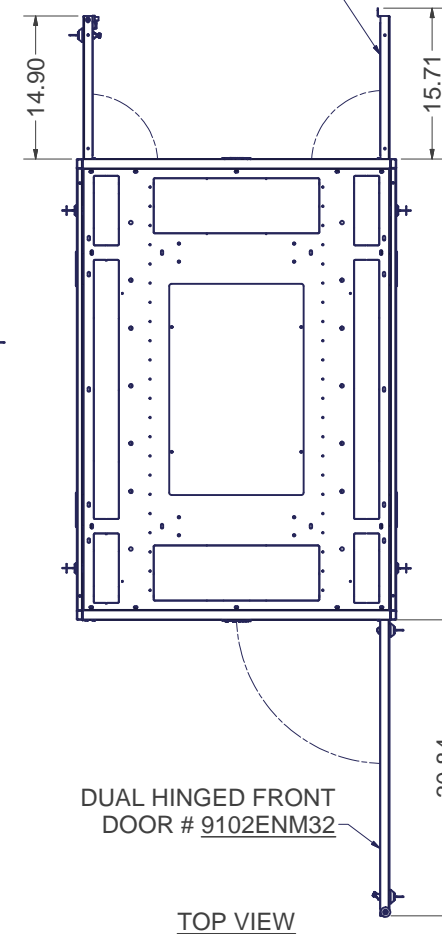

SPECIFICATIONS:

CONFIG. # KIT INCLUDES: QTY. 1 9101ENX3248, BASE FRAME UNIT WITH RAILS
 QTY. 1 9102EN32SM, SPLIT MESH REAR DOOR ASSEMBLY
 QTY. 1 9102ENM32, MESH FRONT DOOR ASSEMBLY
 QTY. 2 9110481ENLS, SOLID LIFT-OFF SIDE PANEL ASSEMBLY

DIMENSIONS: 91.0"H x 32.0"W x 48.0"D

RACK SPACES: 48 RMU w/ NUMBERED RMU INDICATORS, 19" EIA 310-D COMPLIANT.

COLOR: DURABLE TEXTURED BLACK POWDER COATING

CONSTRUCTION: FULL WELDED FRAME WITH RECESSED #12 GA CORNER POSTS
 1 PAIR FIXED #12 GA RAILS, 1 PAIR ADJUSTABLE DEPTH #12 GA RAILS,
 #16 C.R.S DOORS, SOLID TOP PANEL & SIDE PANELS OF ALUMINUM

HARDWARE: PACKAGE OF QTY-50; #10-32 SCREWS -OR- M6 SCREWS W/ CAGE NUTS, INCLUDED.

(8) LEVELING GLIDES IN 1/2-13 UNC THREADED HOLES

EST. WEIGHT : 419.67 lbmass

THIRD ANGLE PROJECTION

INTERPRET DRAWING PER ASME Y14.5M-1994
 DIMENSIONAL LIMITS APPLY AFTER APPLICATION OF FINISH
 DRAWING NOT TO SCALE
 TOLERANCE UNLESS OTHERWISE NOTED:
 ANGULAR +/- 1'
 .XXXX +/- .010
 .XXX +/- .015
 .XX +/- .030
 .X FOR REF. ONLY
 UNLESS OTHERWISE SPECIFIED ALL DIMENSIONS ARE IN INCHES

NOTICE:

Use of this document is subject to a confidentiality and nondisclosure agreement with Great Lakes Case & Cabinet Co., Inc. (GLCC) and may not be reproduced, disclosed or utilized in whole or in part without prior written authorization from GLCC.

PART NUMBER: SEE CHART
 QTY PER UNIT: 1
 MATERIAL TYPE:
 MATERIAL GAUGE:
 FINISH:
 DRAWN: DATE 5/15/2014
 FED: DATE 5/15/2014
 CHECKED & APP. DATE 5/15/2014
 WSS

TITLE: EN FRAME, 91"H x 32"W x 48"D w/ SOLID TOP, DUAL HINGE PERF FRONT DOOR, SPLIT PERF REAR DOOR, SOLID SIDES & 48 RU RAILS
 GREAT LAKES CASE & CABINET CO., INC.
 P.O. BOX 551 EDINBORO, PA 16412
 PHONE (814) 734-7303 FAX (814) 734-3907
 E-MAIL glcc@greatcabinets.com
 DWG NO. REV
SEE CHART SHEET: 1 OF 1