

CONFIG PART #

840ENT4042SSS	840EN4042SSS
EN FRAME 84"H x 40"W x 42"D WITH 2 PAIR OF 45 RMU #10-32 TAPPED RAILS, CABLE MANAGEMENT FINGERS ON ALL RAILS, SOLID TOP, SPLIT PERF FRONT DOOR & REAR DOOR AND SOLID SIDE PANELS	EN FRAME 84"H x 40"W x 42"D WITH 2 PAIR OF 45 RMU M6 RAILS, CABLE MANAGEMENT FINGERS ON ALL RAILS, SOLID TOP, SPLIT PERF FRONT DOOR & REAR DOOR AND SOLID SIDE PANELS

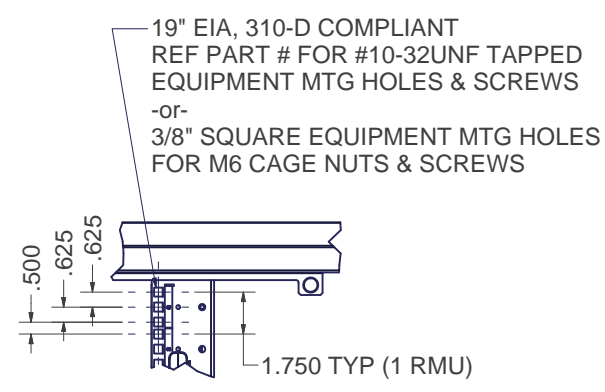

DETAIL C

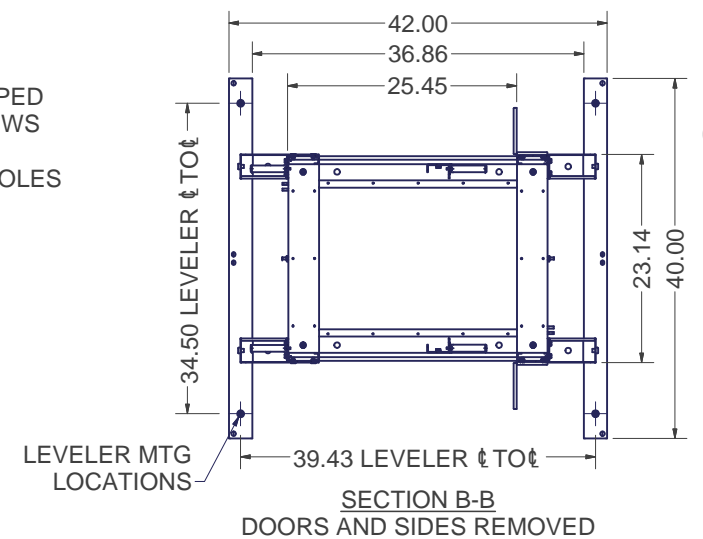

SECTION B-B
DOORS AND SIDES REMOVED

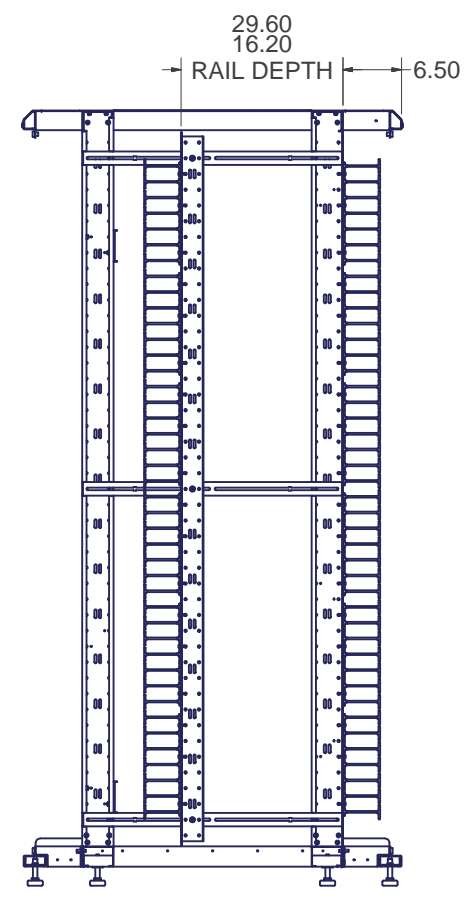

SECTION A-A

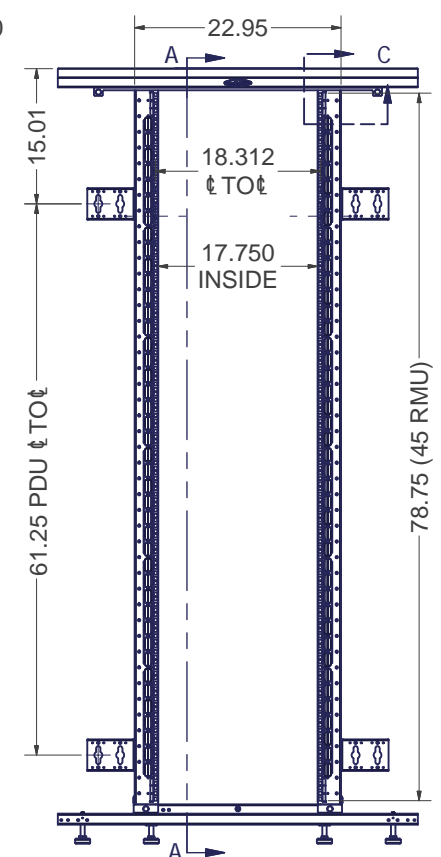

FRONT VIEW
DOORS AND SIDES REMOVED

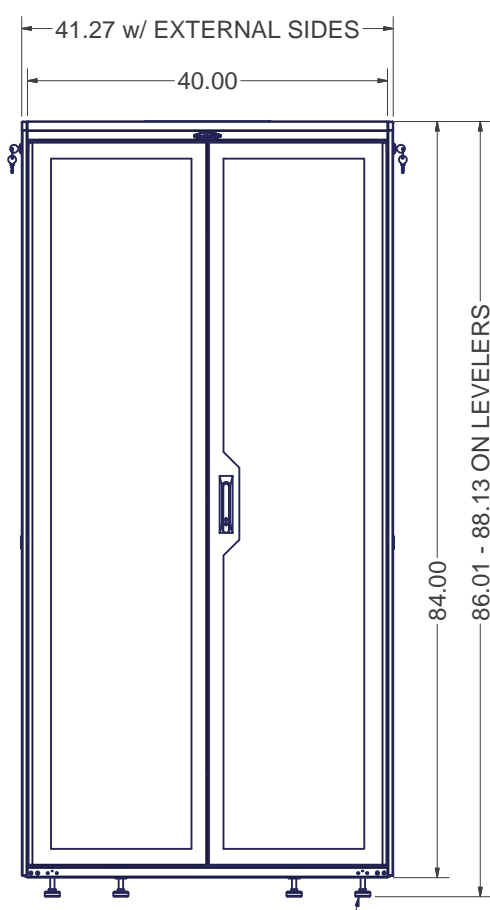

FRONT VIEW

LEVELING GLIDES (8) INCLUDED
1/2-13 UNC THREADED HOLES

INDEPENDENT MOUNTING LOCATIONS FOR LADDER RACK BRACKETS OR TOP MOUNTED CABLE TROUGH OPTIONS

6.63 x 18.50 CABLE PASS THROUGH KNOCKOUTS (122.6 sq.in.), 4 PLACES

4.25 x 17.25 CABLE PASS THROUGH KNOCKOUTS (73.3 sq.in.), 2 PLACES

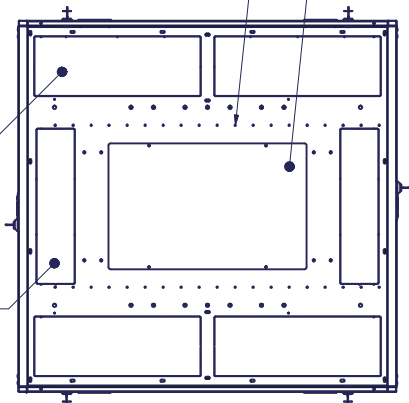

TOP VIEW

SOLID SIDE PANELS, PART #8410481ENLS ON BOTH SIDES

TOP PANEL OPENING (273 sq.in.); SOLID, VENTED, OR w/ EXHAUST FANS FLOWING UP TO 1100 CFM

SPLIT MESH FRONT & REAR DOORS, PART #8402EN40SM

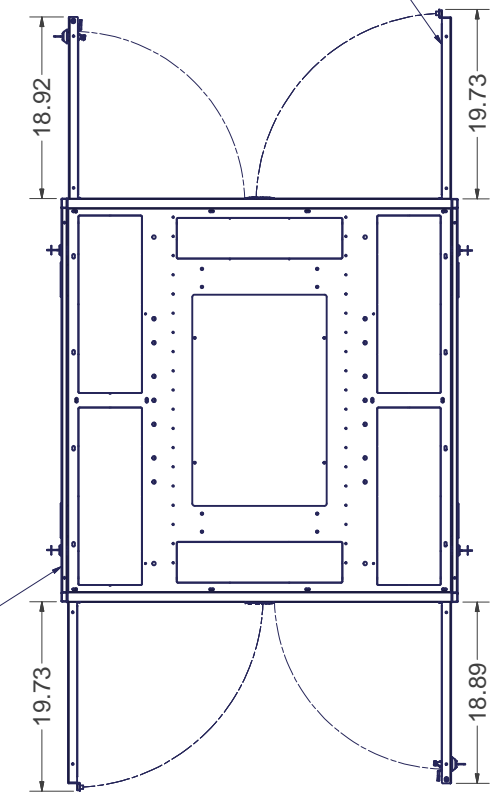

TOP VIEW

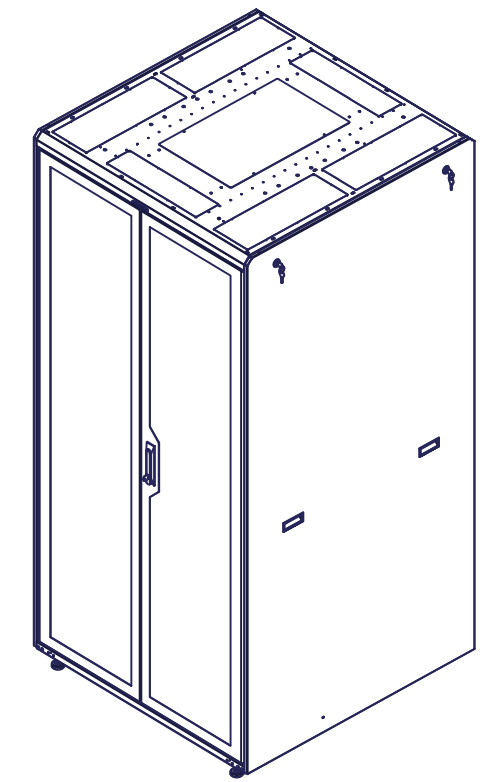

CLOSED VIEW

SPECIFICATIONS:

CONFIG. # KIT INCLUDES: QTY. 1 8401EN4042, BASIC FRAME UNIT WITH RAILS
QTY. 2 8402EN40SM, SPLIT MESH REAR DOOR ASSEMBLIES
QTY. 2 8410481ENLS, SOLID LIFT-OFF SIDE PANEL ASSEMBLIES

DIMENSIONS : 84.0"H x 40.0"W x 42.0"D

RACK SPACES : 45 RMU w/ NUMBERED RMU INDICATORS, 19" EIA 310-D COMPLIANT.

COLOR : DURABLE TEXTURED BLACK POWDER COATING

CONSTRUCTION : FULL WELDED STEEL FRAME WITH RECESSED #12 GA CORNER POSTS (1 PAIR) FIXED #12 GA RAILS, (1 PAIR) ADJUSTABLE DEPTH #12 GA RAILS DOORS #16 C.R.S. & SIDE PANELS LIGHT-WEIGHT ALUMINUM

HARDWARE : PACKAGE OF (QTY 50); #10-32 SCREWS -or- M6 SCREWS W/ CAGE NUTS, INCLUDED.

EST. WEIGHT :
417.28 lbmass



INTERPRET DRAWING PER ASME Y14.5M-1994
DIMENSIONAL LIMITS APPLY AFTER APPLICATION OF FINISH
DRAWING NOT TO SCALE
TOLERANCE UNLESS OTHERWISE NOTED:
ANGULAR +/- .1°
.XXXX +/- .010
.XXX +/- .015
.XX +/- .030
.X FOR REF. ONLY
UNLESS OTHERWISE SPECIFIED ALL DIMENSIONS ARE IN INCHES

NOTICE:
Use of this document is subject to a confidentiality and nondisclosure agreement with Great Lakes Case & Cabinet Co., Inc. (GLCC) and may not be reproduced, disclosed or utilized in whole or in part without prior written authorization from GLCC.

PART NUMBER:	SEE CHART
QTY PER UNIT:	1
MATERIAL TYPE:	
MATERIAL GAUGE:	
FINISH:	
DRAWN:	DATE
FED	5/12/2014
CHECKED & APP.:	DATE
WSS	5/12/2014

TITLE	EN FRAME, 84"H x 40"W x 42"D, w/ SPLIT PERF FRONT & REAR DOORS & SOLID SIDES
GREAT LAKES CASE & CABINET CO., INC.	
P.O. BOX 551 EDINBORO, PA 16412	
PHONE (814) 734-7303 FAX (814) 734-3907	
E-MAIL glcc@greatcabinets.com	
DWG NO.	REV
SEE CHART	
SHEET: 1 OF 1	