

CONFIG PART #

840ENT3248MSS-NS

840EN3248MSS-NS

EN FRAME 84"H x 32"W x 48"D WITH 2 PAIR OF 45 RMU #10-32 TAPPED RAILS, CABLE MANAGEMENT FINGERS ON ALL RAILS, SOLID TOP, DUAL HINGE PERF FRONT DOOR, SPLIT PERF REAR DOOR

EN FRAME 84"H x 32"W x 48"D WITH 2 PAIR OF 45 RMU M6 RAILS, CABLE MANAGEMENT FINGERS ON ALL RAILS, SOLID TOP, DUAL HINGE PERF FRONT DOOR, SPLIT PERF REAR DOOR

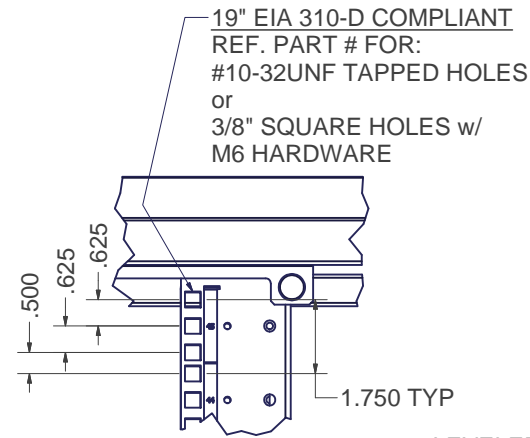

DETAIL C

LEVELER MTG. LOCATIONS

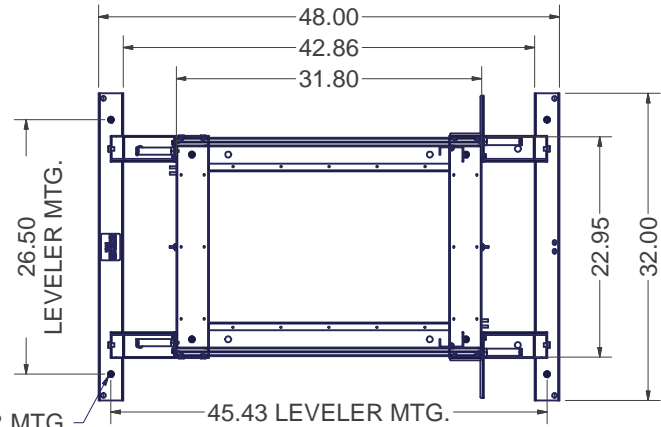

SECTION B-B
DOORS AND SIDES REMOVED

INDEPENDENT MOUNTING LOCATIONS FOR LADDER RACK BRACKETS OR TOP MOUNTED CABLE TROUGHS

TOP PANEL OPENING (273 sq.in.) SOLID, VENTED, OR w/ EXHAUST FANS FOR UP TO 1100 CFM

5.75 x 17.25 CABLE PASS THROUGH KNOCKOUT (99.2 sq.in.), 2 PLACES

2.63 x 7.25 CABLE PASS THROUGH KNOCKOUTS (19.1 sq.in.), 4 PLACES

2.63 x 27.00 CABLE PASS THROUGH KNOCKOUTS (71 sq.in.), 2 PLACES

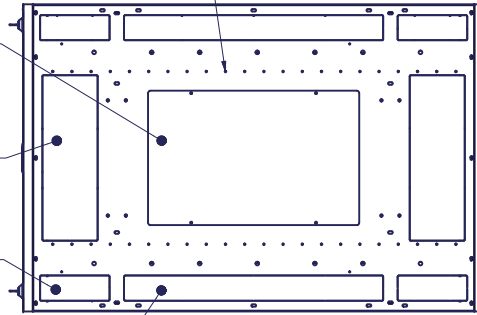

TOP VIEW

SPLIT MESH REAR DOORS PART # 8402EN32SM

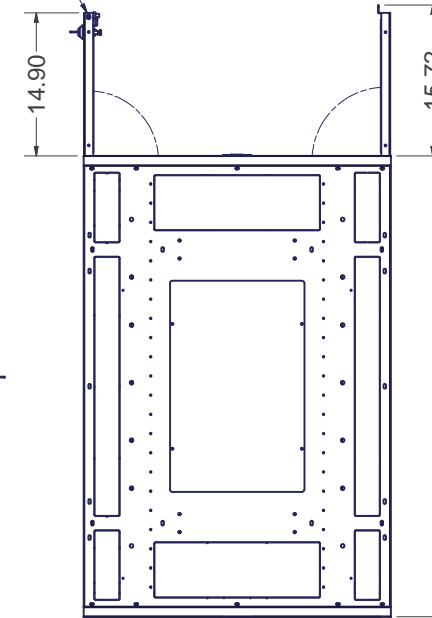

SPLIT MESH FRONT DOOR PART # 8402ENM32

TOP VIEW

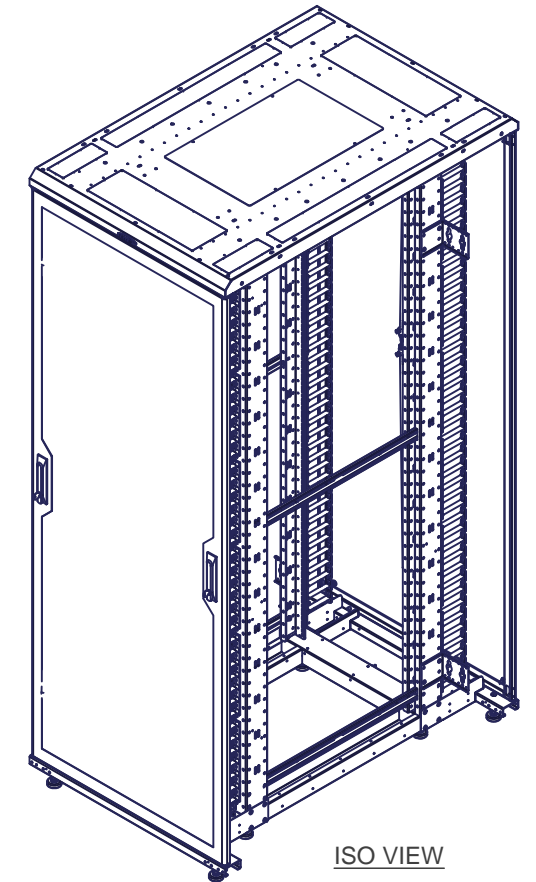

ISO VIEW

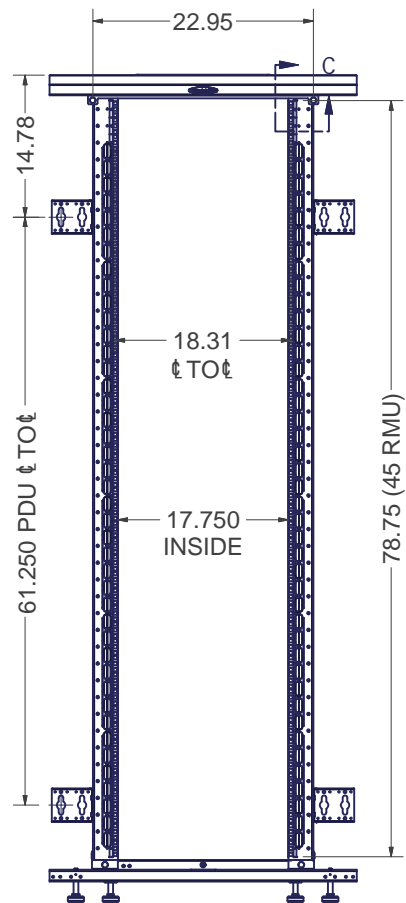

FRONT VIEW
DOORS AND SIDES REMOVED

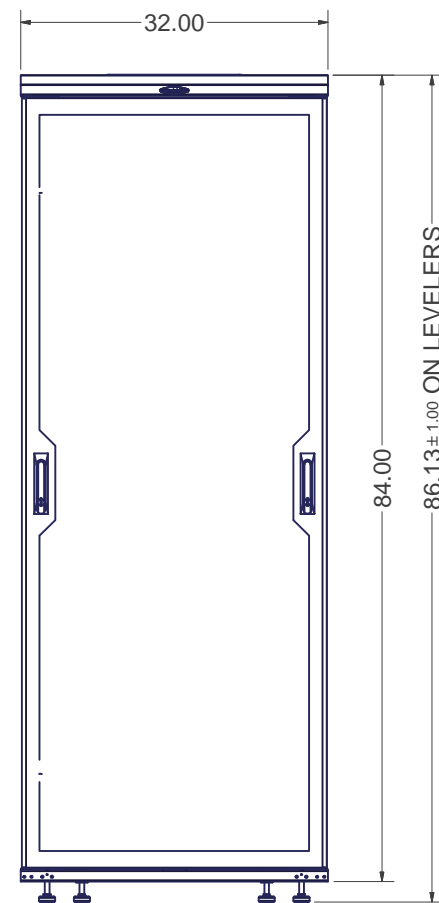

FRONT VIEW

(8) LEVELING GLIDES IN 1/2-13 UNC THREADED HOLES

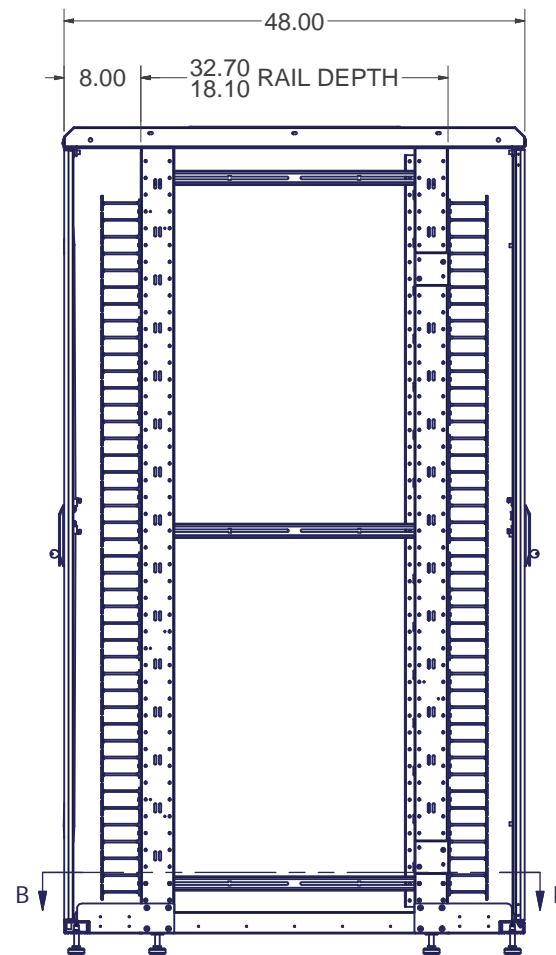

RIGHT SIDE VIEW

SPECIFICATIONS:

CONFIG. # KIT INCLUDES: QTY. 1 8401ENX3248, BASE FRAME UNIT WITH RAILS
QTY. 1 8402EN32SM, SPLIT MESH REAR DOOR ASSEMBLY
QTY. 1 8402ENM32, MESH FRONT DOOR ASSEMBLY

DIMENSIONS : 84.0"H x 32.0"W x 48.0"D

RACK SPACES : 45 RMU w/ NUMBERED RMU INDICATORS, 19" EIA 310-D COMPLIANT.

COLOR : DURABLE TEXTURED BLACK POWDER COATING

CONSTRUCTION : FULL WELDED FRAME WITH RECESSED #12 GA CORNER POSTS
1 PAIR FIXED #12 GA RAILS, 1 PAIR ADJUSTABLE DEPTH #12 GA RAILS
#16 C.R.S. DOORS & SOLID TOP PANEL

HARDWARE : PACKAGE OF QTY-50; #10-32 SCREWS -OR- M6 SCREWS W/ CAGE NUTS, INCLUDED.

EST. WEIGHT : 333.81 lbmass



INTERPRET DRAWING PER ASME Y14.5M-1994
DIMENSIONAL LIMITS APPLY AFTER APPLICATION OF FINISH
DRAWING NOT TO SCALE
TOLERANCE UNLESS OTHERWISE NOTED:
ANGULAR +/- .1"
.XXXX +/- .010
.XXX +/- .015
.XX +/- .030
.X FOR REF. ONLY

UNLESS OTHERWISE SPECIFIED ALL DIMENSIONS ARE IN INCHES

NOTICE:

Use of this document is subject to a confidentiality and nondisclosure agreement with Great Lakes Case & Cabinet Co., Inc. (GLCC) and may not be reproduced, disclosed or utilized in whole or in part without prior written authorization from GLCC.

PART NUMBER: SEE CHART	
QTY PER UNIT: 1	
MATERIAL TYPE: -	
MATERIAL GAUGE: -	
FINISH: -	
DRAWN CD	DATE 2/8/2011
CHECKED & APP. WSS	DATE 2/9/2011

TITLE EN FRAME 84"H x 32"W x 42"D W/ DUAL HINGE PERF FRONT DOOR, SPLIT PERF REAR DOOR, SOLID TOP PANEL & 45 RU RAILS	
GREAT LAKES CASE & CABINET CO., INC. P.O. BOX 551 EDINBORO, PA 16412 PHONE (814) 734-7303 FAX (814) 734-3907 E-MAIL glcc@greatcabinets.com	
DWG NO. SEE CHART	REV
SEE CHART	SHEET: 1 OF 1