



ORTRONICS

125 EUGENE O'NEILL DRIVE
NEW LONDON, CT 06320
TEL: 860-445-3800
FAX: 860-405-2990

TITLE: TechChoice KEYSTONE JACK	
INSTRUCTION SHEET #:	71601440
REVISION:	01
DATE: 12/15/04	SIDE 1 of 2

CAUTION: TERMINATE JACKS PER SPECIFIED WIRING SYSTEM 'T568A' or 'T568B'.

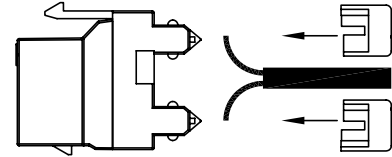
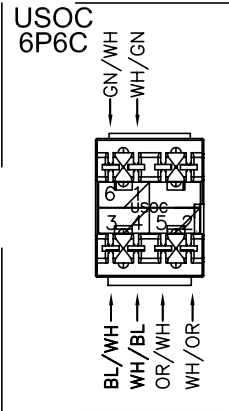
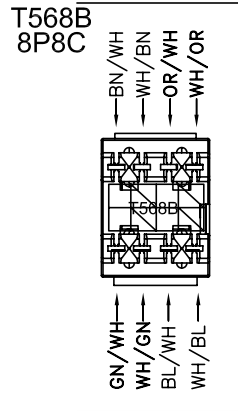
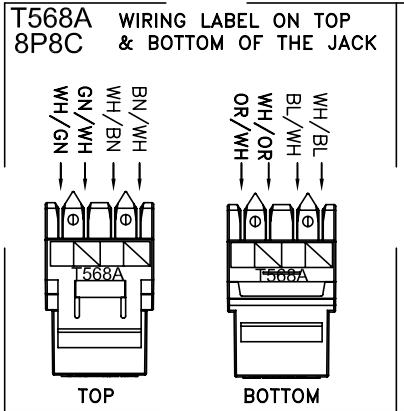

NOTE: When terminating cables to Jacks, lace wires from the center to the outside of the module. Install stuffer caps after terminating cable.

'This device is intended for indoor use on communication loop circuit which have been isolated from the Public Switched Telephone Network'.

WIRING CHART

COLOR CODE LABEL	RJ25 6P6C USOC WIRING	RJ45 8P8C T568A WIRING	RJ45 8P8C T568B WIRING
WHITE/BLUE	4	5	5
BLUE/WHITE	3	4	4
WHITE/ORANGE	2	3	1
ORANGE/WHITE	5	6	2
WHITE/GREEN	1	1	3
GREEN/WHITE	6	2	6
WHITE/BROWN		7	7
BROWN/WHITE		8	8

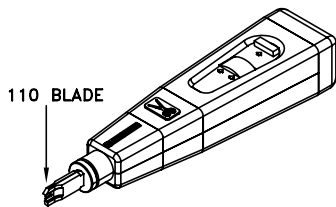

REQUIRED TERMINATION TOOL
OR-60300005 (TOOL & BLADE)
OR-60300006 (BLADE ONLY)

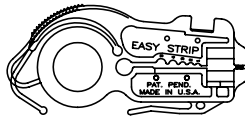

RECOMMENDED STRIPPING TOOL
OR-60300032 (TOOL)

Jack Module Termination

- STEP 1: Strip 2" of cable jacket off station cables.
- STEP 2: Lace color coded wire pairs into 110 termination, as indicated above.
NOTE: Maintain cable pair twists within 1/2" (13mm) from the point of termination.
- STEP 3: Place Jack on solid flat surface to terminate. Using a single insertion blade 110 tool, terminate all 4 pairs. (see above diagram)
- STEP 4: Repeat steps 1 thru 3 until all Jack Modules are terminated.
- STEP 5: Snap Jack module into faceplate, or set Jack module into base of surface mount box.

