

REVISIONS				
LR	DESCRIPTION	ECN NO.	DATE	APPROVED
A	CREATE DRAWING		3/9/10	DWR
B	REMOVE ITEM #8 (2003-2650)	9024	7/16/10	MTH
C	ADD ITEM 8 SPECIFICATION	12780	8/25/14	MTH

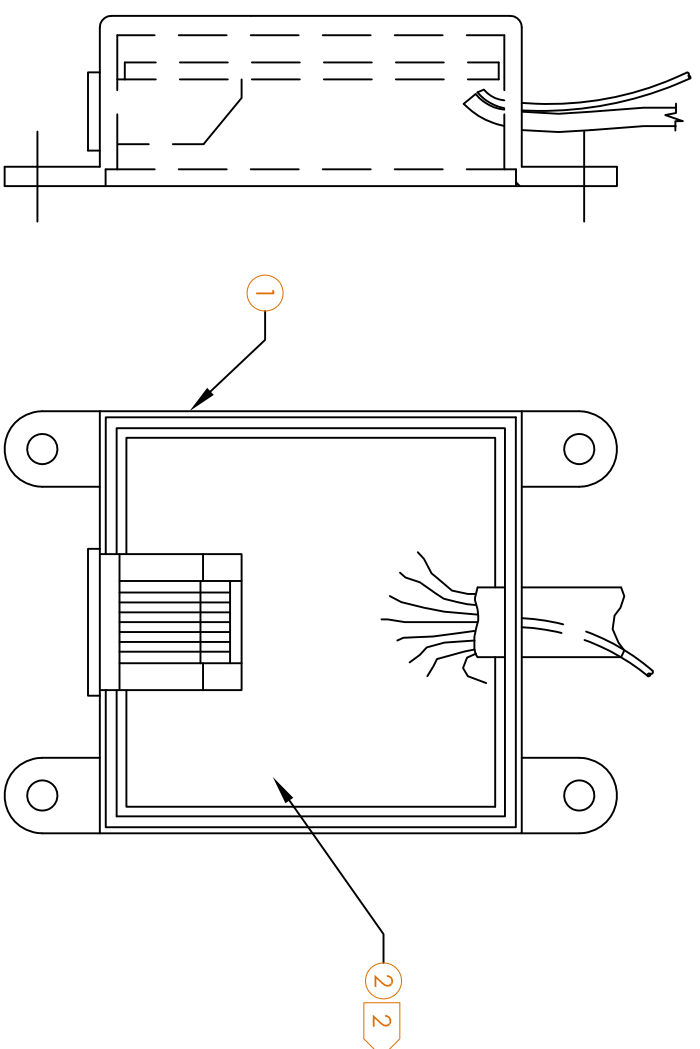

- NOTES:
- TEST PCB ASSEMBLY, PLACE INTO CASE AND SONIC WELD. RETEST AFTER SONIC WELDING.
 - TRIM ALL LEADS FROM SUPPRESSORS AND CONNECTOR ALLOWING PCB TO SET FLUSH IN CASE BEFORE SONIC WELDING.
 - PLACE LABEL ON BACK OF LID.
 - EXTRA LABEL GOES ON PACKAGING.

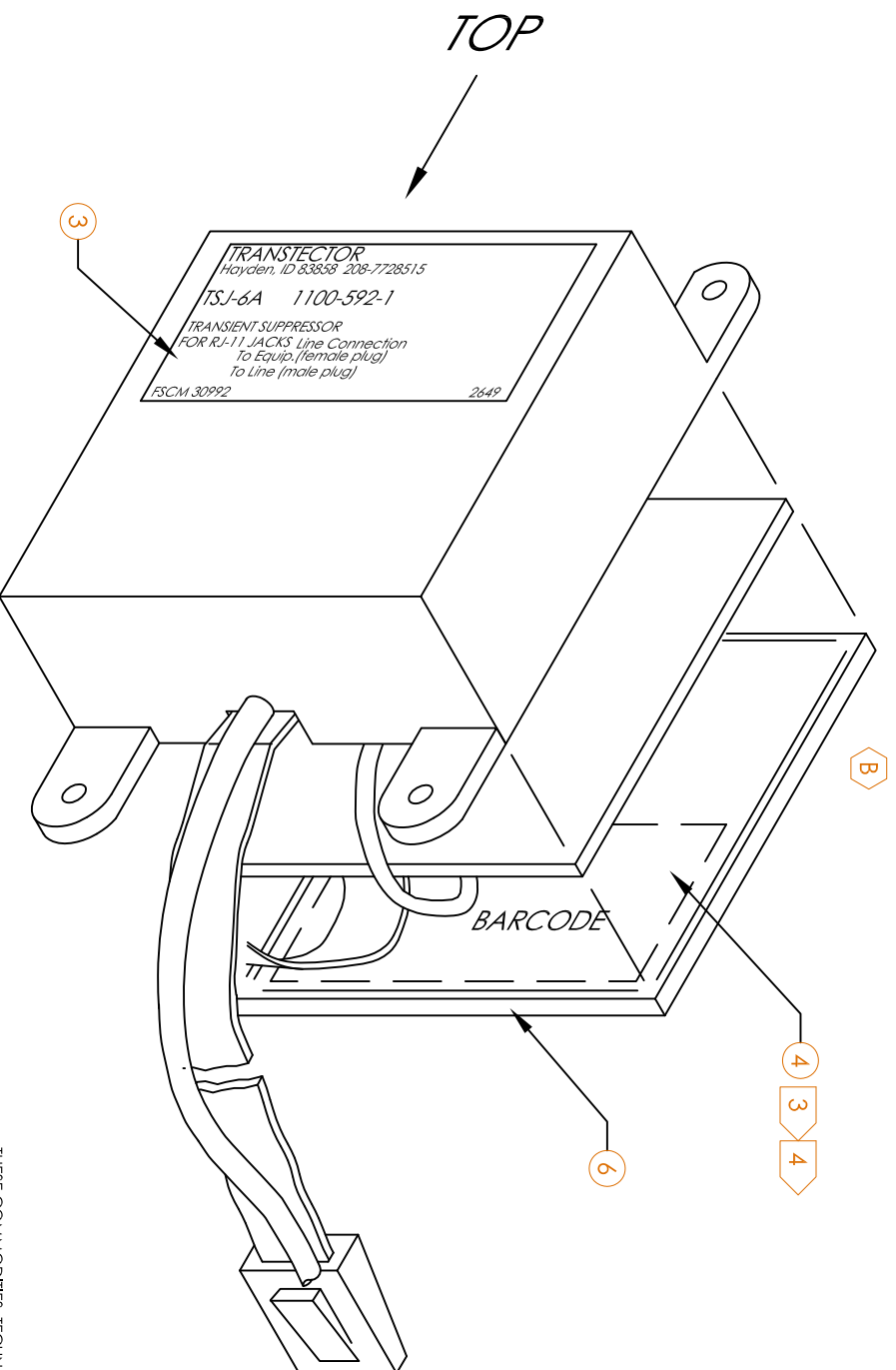

ITEM	QTY	PART NUMBER	DESCRIPTION
8	REF	1400-439	SPEC TSJ 6A
7	1	8050-014	PACKAGING SUPPLIES TSJ 6A
6	1	2001-049	CASE COVER 2.140 X 2.140
5	REF	1800-098	SCHEM TSJ 6
4	2	2003-1052	LABEL SERIAL/LOTTED CODE
3	1	2003-2649	LABEL TSJ 6A 1100-592-1
2	1	2250-042	PCB ASSY TSJ 6
1	1	2001-052	CASE TSJ 6 FAMILY X1

PARTS LIST

ALL DIMENSIONS IN INCHES UNLESS OTHERWISE SPECIFIED.

TOLERANCES:
 FRACTIONS = ±
 ANGLES = ± °
 MATERIAL: XXX = ±
 NOTED

THIRD-ANGLE PROJECTION

NOTICE: THE INFORMATION AND DESIGN IN THIS DOCUMENT IS THE PROPERTY OF TRANSECTOR SYSTEMS. ALL RIGHTS RESERVED.

DRAWN	LLW	DATE	3/9/10
CHECKED	DPM	3/18/10	
ENG APPD	TOT	3/18/10	
PROJ APPD	DWR	3/19/10	
PROJECT NO.			

TRANSECTOR	10701 Airport Drive, Hayden, ID 83835, USA
	+1.208.772.8515 FAX +1.208.762.6034
	800.882.9110 www.transector.com

NOTICE: THE INFORMATION AND DESIGN IN THIS DOCUMENT IS THE PROPERTY OF TRANSECTOR SYSTEMS. ALL RIGHTS RESERVED.

SCALE = NA

SIZE	CAGE	DRAWING NUMBER	REV
B	30992	1100-592-1	C
PRODUCT CATEGORY	DST	SHEET	1 of 1

THESE COMMODITIES, TECHNOLOGY OR SOFTWARE WERE EXPORTED FROM THE UNITED STATES IN ACCORDANCE WITH THE EXPORT ADMINISTRATION REGULATIONS, DIVERSION CONTRARY TO U.S. LAW PROHIBITED.