

INTEGRATED AUDIO COLLABORATION SYSTEM

AM-CF1B, AM-CF1W

Thank you for purchasing TOA's Integrated Audio Collaboration System.

Please carefully follow the instructions in this manual to ensure long, trouble-free use of your equipment.

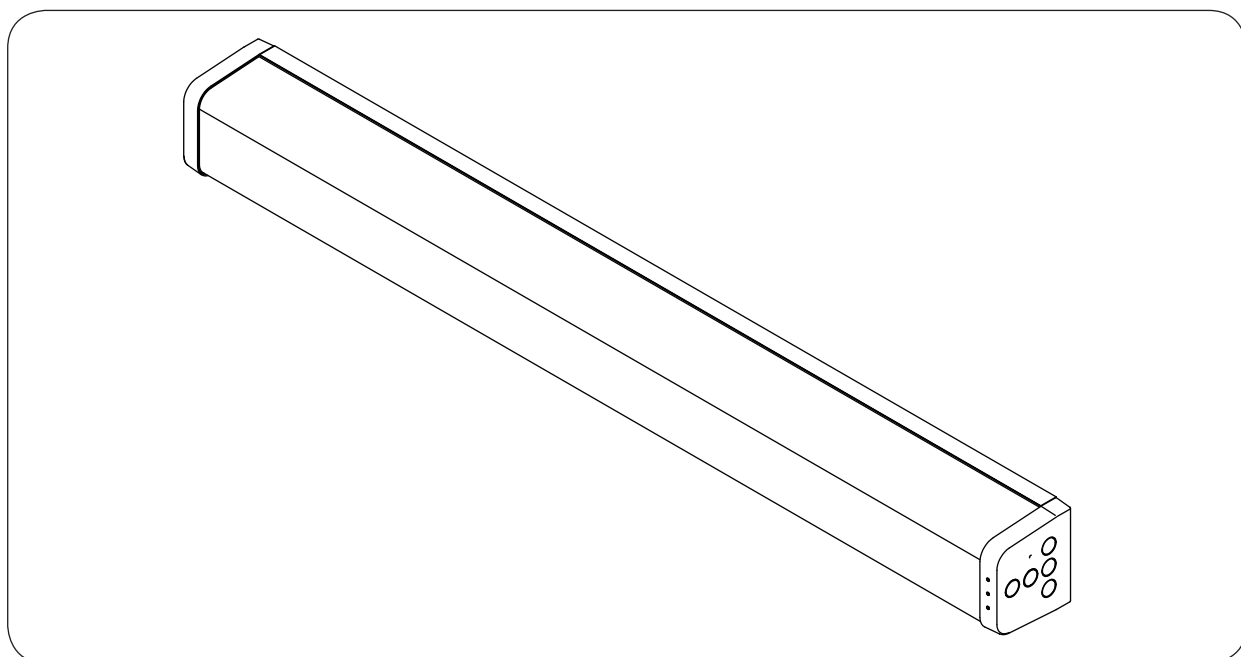

TABLE OF CONTENTS

1. SAFETY PRECAUTIONS	2	8.2. System Requirements	11
2. GENERAL DESCRIPTION	3	8.3. Connections	11
3. FEATURES	3	9. OPERATION	12
4. NOMENCLATURE AND FUNCTIONS	4	9.1. Turning Power ON and OFF	12
5. CONNECTION EXAMPLES	6	9.2. Switching between Power Standby and Normal Operation modes	12
6. INSTALLATION	6	9.3. Turning Power OFF	12
7. CONNECTIONS	8	9.4. Bluetooth Pairing	12
7.1. AC Adapter Connection	8	9.5. Volume Adjustment	13
7.2. Network Connection	8	9.6. Microphone Muting	14
7.3. PC and USB Devices Connections	8	10. CONTACT INPUT AND	
7.4. AUX Input Connection	8	OUTPUT FUNCTIONS	14
7.5. AUX Output Connection	9	10.1. Terminal Control Method (Momentary/Latch)	14
7.6. Control Input and Output Connections ...	9	10.2. Contact Input Settings	15
7.7. Codec Input and Output Connections ...	10	10.3. Contact Output Settings	15
7.8. Removable Terminal Plug Connection .	10	11. SPECIFICATIONS	16
8. SYSTEM SETTINGS	11	Accessories	16
8.1. Overview of System Settings	11		

1. SAFETY PRECAUTIONS

- Before installation or use, be sure to carefully read all the instructions in this section for correct and safe operation.
- Be sure to follow all the precautionary instructions in this section, which contain important warnings and/or cautions regarding safety.
- After reading, keep this manual handy for future reference.

Safety Symbol and Message Conventions

Safety symbols and messages described below are used in this manual to prevent bodily injury and property damage which could result from mishandling. Before operating your product, read this manual first and understand the safety symbols and messages so you are thoroughly aware of the potential safety hazards.



WARNING

Indicates a potentially hazardous situation which, if mishandled, could result in death or serious personal injury.



CAUTION

Indicates a potentially hazardous situation which, if mishandled, could result in moderate or minor personal injury, and/or property damage.



WARNING

When Installing the Unit

- Do not expose the unit to rain or an environment where it may be splashed by water or other liquids, as doing so may result in fire or electric shock.
- Use the unit only with the voltage specified on the unit. Using a voltage higher than that which is specified may result in fire or electric shock.
- Do not cut, kink, otherwise damage nor modify the power supply cord. In addition, avoid using the power cord in close proximity to heaters, and never place heavy objects -- including the unit itself -- on the power cord, as doing so may result in fire or electric shock.
- Install the unit only in a location that can structurally support the weight of the unit and the mounting bracket. Doing otherwise may result in the unit falling down and causing personal injury and/or property damage.
- Since the unit is designed for indoor use, do not install it outdoors. If installed outdoors, the aging of parts causes the unit to fall off, resulting in personal injury. Also, when it gets wet with rain, there is a danger of electric shock.
- Do not use other methods than specified to mount the bracket. Extreme force is applied to the unit and the unit could fall off, possibly resulting in personal injuries.
- Use nuts and bolts that are appropriate for the wall's structure and composition. Failure to do so may cause the unit to fall, resulting in material damage

and possible personal injury.

- Tighten each nut and bolt securely. Ensure that the bracket has no loose joints after installation to prevent accidents that could result in personal injury.
- Use the specified mounting bracket in combination. Doing otherwise may cause the unit or component to fall off, resulting in personal injury.
- Do not mount the unit in locations exposed to constant vibration. The mounting bracket can be damaged by excessive vibration, potentially causing the unit to fall, which could result in personal injury.

When the Unit is in Use

- Should the following irregularity be found during use, immediately switch off the power, disconnect the power supply plug from the AC outlet and contact your nearest TOA dealer. Make no further attempt to operate the unit in this condition as this may cause fire or electric shock.
 - If you detect smoke or a strange smell coming from the unit
 - If water or any metallic object gets into the unit
 - If the unit falls, or the unit case breaks
 - If the power supply cord is damaged (exposure of the core, disconnection, etc.)
 - If it is malfunctioning (no tone sounds)
- To prevent a fire or electric shock, never open nor remove the unit case as there are high voltage components inside the unit.
- Do not place cups, bowls, or other containers of liquid or metallic objects on top of the unit. If they accidentally spill into the unit, this may cause a fire or electric shock.

- Do not touch a power supply plug during thunder and lightning, as this may result in electric shock.



When Installing the Unit

- Never plug in nor remove the power supply plug with wet hands, as doing so may cause electric shock.
- When unplugging the power supply cord, be sure to grasp the power supply plug; never pull on the cord itself. Operating the unit with a damaged power supply cord may cause a fire or electric shock.
- When moving the unit, be sure to remove its power supply cord from the wall outlet. Moving the unit with the power cord connected to the outlet may cause damage to the power cord, resulting in fire or electric shock. When removing the power cord, be sure to hold its plug to pull.
- Avoid installing the unit in humid or dusty locations, in locations exposed to the direct sunlight, near the heaters, or in locations generating sooty smoke or steam as doing otherwise may result in fire or electric shock.
- Avoid touching the unit's sharp metal edge to prevent injury.

When the Unit is in Use

- Do not place heavy objects on the unit as this may cause it to fall or break which may result in personal injury and/or property damage. In addition, the object itself may fall off and cause injury and/or damage.
- Do not operate the unit for an extended period of time with the sound distorting. Doing so may cause the built-in speakers to heat, resulting in a fire.
- Use the AC adapter with the designated specification for the unit. Note that the use of other adapter may cause a fire.
- If dust accumulates on the power supply plug or in the wall AC outlet, a fire may result. Clean it periodically. In addition, insert the plug in the wall outlet securely.
- Switch off the power, and unplug the power supply plug from the AC outlet for safety purposes when cleaning or leaving the unit unused for 10 days or more. Doing otherwise may cause a fire or electric shock.
- Do not stand or sit on, nor hang down from the unit as this may cause it to fall down or drop, resulting in personal injury and/or property damage.

2. GENERAL DESCRIPTION

The AM-CF1B and AM-CF1W Integrated Audio Collaboration Systems are designed to be used in huddle rooms or workspaces.

Software web conferences can be carried out more effectively over laptops by connecting the AM-CF1 to the PCs or web cameras. Even when the conference has multiple participants, not only can each participant's voice be accurately picked up, but each other party's voice can also be reproduced clearly.

Note: The AM-CF1B and AM-CF1W are collectively referred to as "AM-CF1" in this manual.

3. FEATURES

- TOA's unique algorithm detects the speaker's position and controls the array microphone's directivity in real time, allowing the speaker's voice to be more effectively picked up.
- The sound source direction detected by the microphone can be displayed on the front panel LED indicator to inform the speaker that his or her voice is being picked up.
- A built-in USB hub allows connection to web cameras, etc.
- Various settings can be performed for echo cancellation, equalization and the like using a web app.

4. NOMENCLATURE AND FUNCTIONS

[Front]

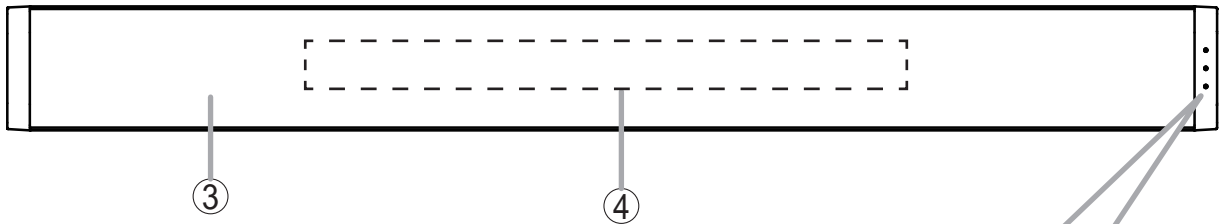

[Side]

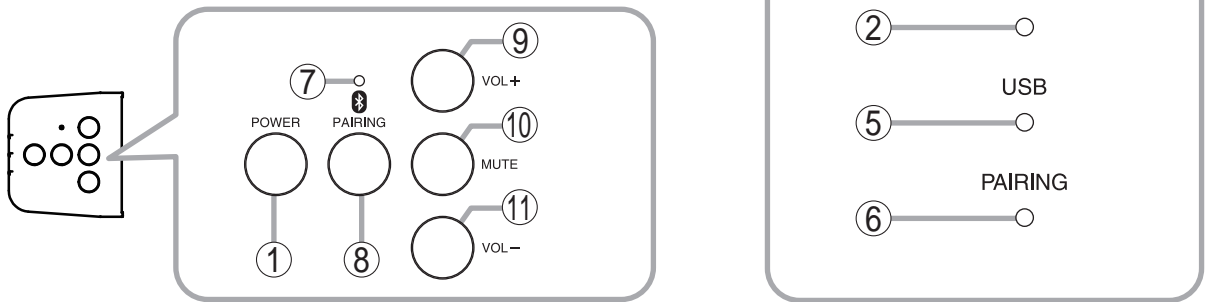

1. Power switch

Hold down this switch for 3 seconds or more to switch between normal operation and power standby mode. To turn OFF the AM-CF1, hold down this switch for over 10 seconds.

2. Power indicator (blue/green/orange/red)

Operating Status		Lighting Status
[When power is ON]	Start processing in progress	Blue ↓ Flashing green ↓ Green
	Unit initialization in progress	Orange
	Normal operation mode	Green
	Power OFF processing in progress	Flashing green ↓ Blue
Power standby mode		Red
Power OFF		Extinguished

3. Microphone & speaker section

An array microphone and a 2-way stereo speaker are housed inside the front panel.

4. Multifunction indicator (green/red)

This indicator is housed inside the front panel and provide 3 different displays using 7 LEDs. Lighting operations differ depending on the contents being displayed.

- (1) When displaying the microphone input level:
When the AM-CF1 unit is in use at a web conference, etc., only one LED facing in the direction of the speaker's voice lights green. The LED's brightness varies depending on the microphone's input level and the louder the input level, the brighter it shines. The LED remains unlit when the microphone input is small or the microphone input level display function is set to OFF.
- (2) When the microphone is muted:
When the Mute switch (10) on the side panel is pressed and the microphone output is muted, the indicator lights red. Whether a single LED or an LED bar light can be selected in the web app settings. (See p. 11.)
- (3) When adjusting the output volume:
The indicator lights green when changing the output volume using the Volume Up (9) or Down (11) switches located on the side panel. Current output volume setting status is displayed. (See p. 13.)

5. USB connection indicator (green)

Lights when a PC is connected to the PC USB port (16).

6. Bluetooth Indicator (Blue)
Remains lit while Bluetooth is connected.
Flashes during pairing registration.

7. Reset Switch
Used to reset the AM-CF1 unit.

8. Bluetooth Pairing Switch
Press this key when pairing with a Bluetooth-compatible device. Pressing this key while the Bluetooth is connected cuts off the Bluetooth.

9. Volume Up Switch
Increases the volume of the AM-CF1 unit's internal speaker when pressed.

10. Mute Switch
Mutes sound picked up at the microphone.

11. Volume Down Switch
Decreases the volume of the AM-CF1 unit's internal speaker when pressed.

[Rear]

Appearance with a wall mounting bracket detached

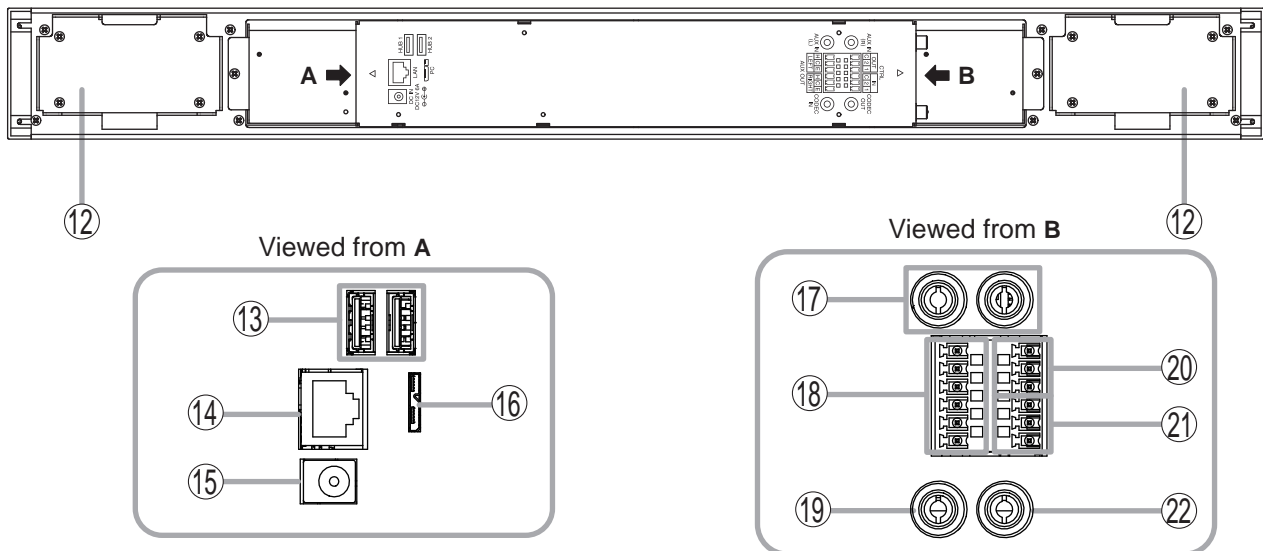

12. Mounting bracket connector
Used to mount the AM-CF1 unit to a wall in combination with the supplied wall mounting bracket.

13. USB ports
USB devices such as a web camera or smart board can be connected to these USB 3.0-compatible ports.

14. Network connection terminal
Connects to networks that support 10BASE-T or 100BASE-TX.
When connecting the PoE extender, use the following:
TPE-117GI (made by TRENDnet)

15. Power input terminal
Connect a 12 V DC power source to this terminal. For AC adapters, use the type with the following specifications.
Output: 12 V DC, 5 A, positive tip polarity
Note: AC adapter not included

16. PC USB port
Connect a PC to this USB 3.0-compatible port.

17. AUX input jacks
RCA pin jack x 2
-10 dB*¹, 10 kΩ, unbalanced type, stereo

18. AUX output block
Removable terminal block (6 pins)
+4 dB*², 600 Ω, balanced (electronically-balanced) type, stereo

19. Codec input jack (monaural input)
RCA pin jack, -10 dB*¹, 10 kΩ, unbalanced type

20. General-purpose control output block
Removable terminal block (6 pins). Make contact output using a relay.
The relay's contact rating is as follows:
Withstand voltage: 40 V DC
Control current: 2 – 300 mA

21. General-purpose control input block
Removable terminal block (6 pins). No-voltage make contact input.
Short-circuit current: 2 mA or less
Open-circuit voltage: 12 V DC or less

22. codec output jacks (monaural)
RCA pin jack, -10 dB*¹, 600 Ω, unbalanced type

*1 0 dB = 1 V

*2 0 dB = 0.775 V

5. CONNECTION EXAMPLES

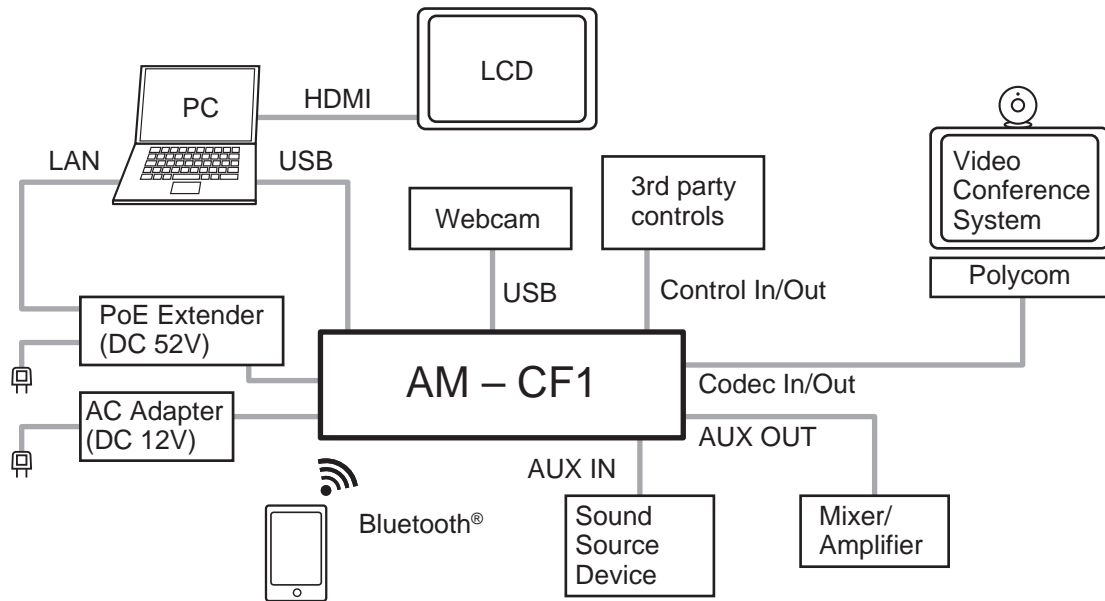

6. INSTALLATION

Follow the procedures below to mount the AM-CF1 unit to a wall:



WARNING

Be sure to use the following wall mounting brackets and screws. If hardware other than that mentioned below is used, the unit could fall down, potentially resulting in damage and personal injury.

Step 1. Remove the 4 screws fixing the wall mounting bracket as illustrated below and detach the bracket from the AM-CF1 unit.

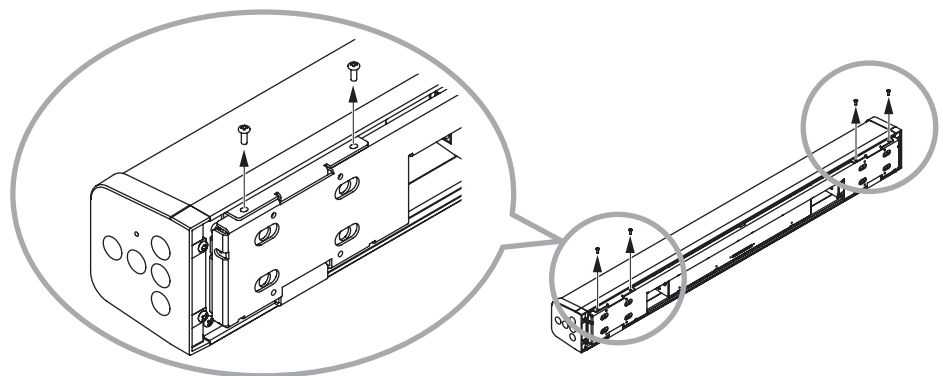

Step 2. Attach the wall mounting bracket to a wall. Separately prepare anchor bolts and other hardware needed for wall mounting.

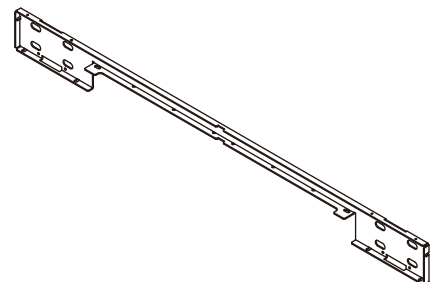

Step 3. Hook the unit's lower mounting tab (A in the figure at right) into the mounting bracket mounted on the wall.

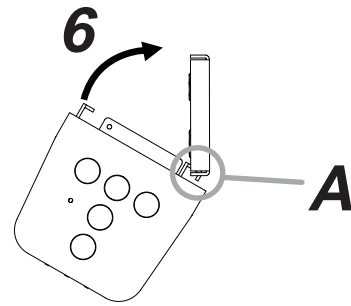

Step 4. Make necessary connections.
For connection method, see p. 3.

Step 5. Bind connected wires using a tying tool or the like.

Step 6. After connection is completed, tilt the unit upward with the tab hooked in **Step 3** as a supporting point.

Step 7. If the upper tab (B in the figure at right) contacts the bracket on the wall, shift the unit slightly upward and hook the upper tab to the bracket on the wall.

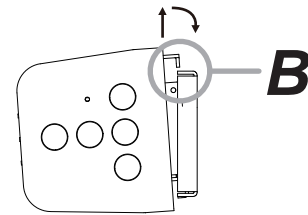

Step 8. Secure the unit to the bracket using the screws removed in **Step 1**.

Note

Screws can be installed not only from the upward direction, but also from the side or downward direction.

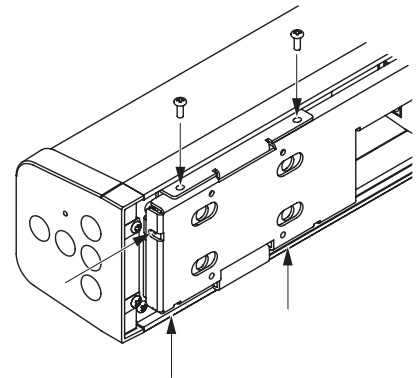

7. CONNECTIONS

7.1. AC Adapter Connection

Connect the AC adapter*1 to the AM-CF1's power input terminal.

*1 Use the AC adapter with the following specification.

[Usable AC adapter]

Output : 12 V DC, 5 A, positive tip polarity

Note: AC adapter not included

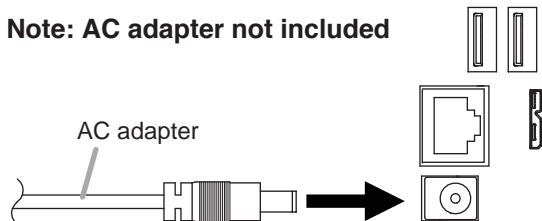

⚠ CAUTION

For AC adapters, use the adapter with the designated specification. The use of other adapters could result in fire or other possible damage.

7.2. Network Connection

The AM-CF1 automatically distinguishes between 10BASE-T and 100BASE-TX networks and establishes a connection. For this connection, use a straight UTP Category 5 or greater LAN (Ethernet) cable terminated with an RJ-45 connector.

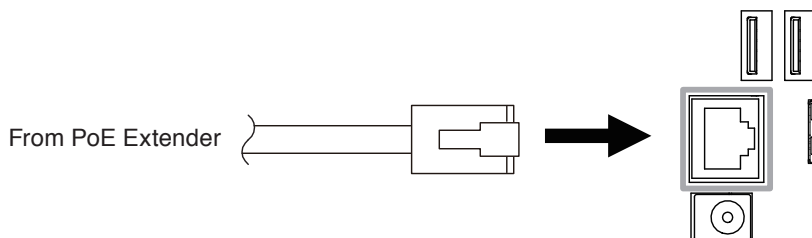

7.3. PC and USB Devices Connections

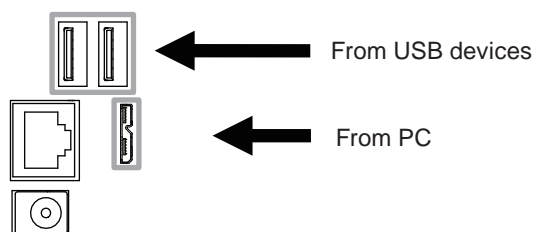

7.4. AUX Input Connection

AUX input jacks are intended exclusively for stereo input (LINE level).

When connecting a monaural sound source, connect the L line.

[AUX input]

RCA pin jack x2

-10 dB*2, 10 kΩ, unbalanced

*2 0 dB = 1 V

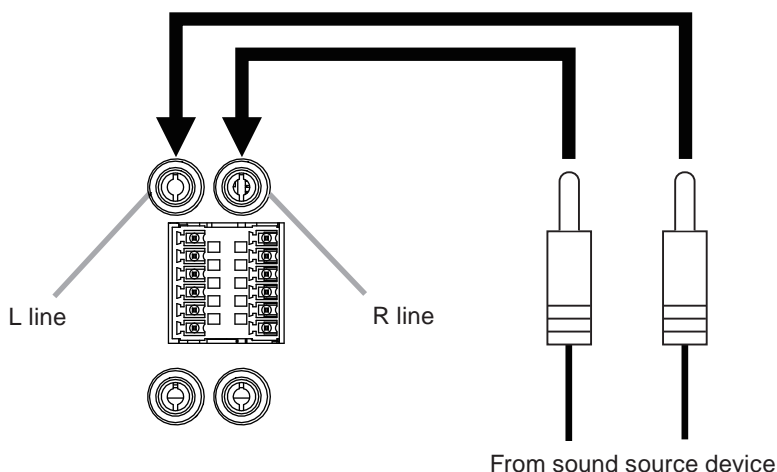

7.5. AUX Output Connection

Use the supplied removable terminal plugs (6 pins) for connection.
 AUX output is set to LINE level input.
 For removable terminal plug connections, see p. 10.

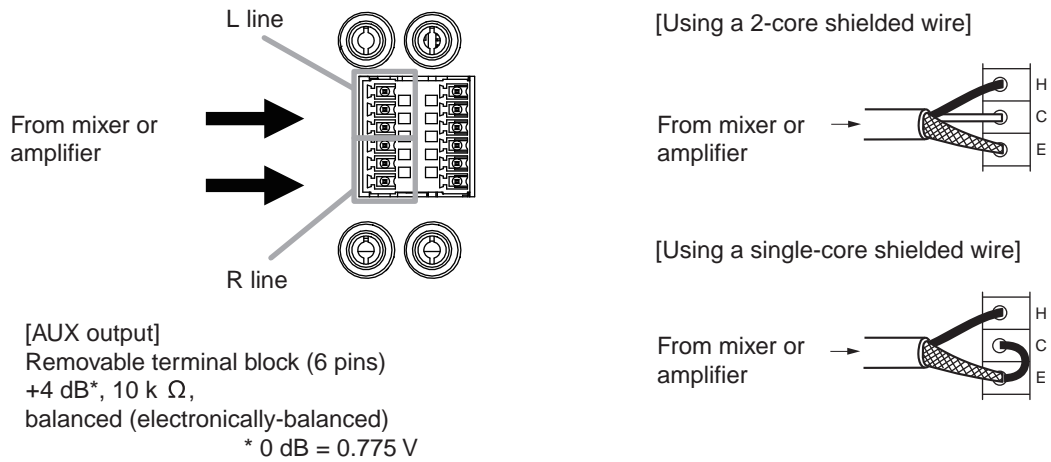

7.6. Control Input and Output Connections

Use the supplied removable terminal plug (6 pins) for connection.
 Connect the control input and output blocks using 2 control lines from external control devices.
 For removable terminal plug connections, see p. 10.
 For contact input and output functions, see p. 14.

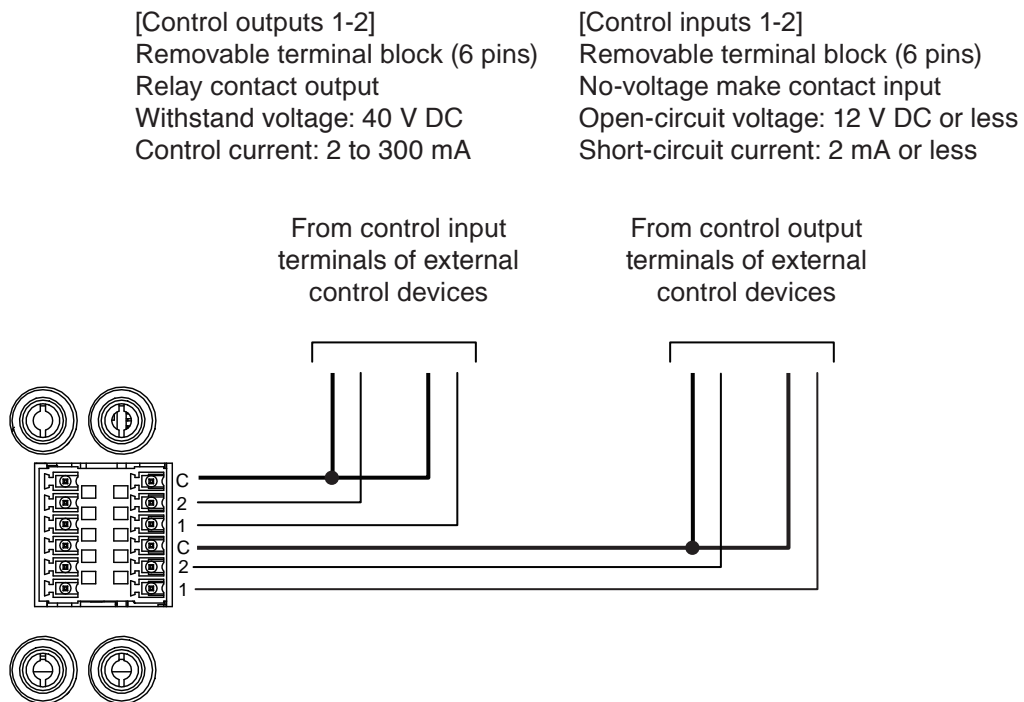

7.7. Codec Input and Output Connections

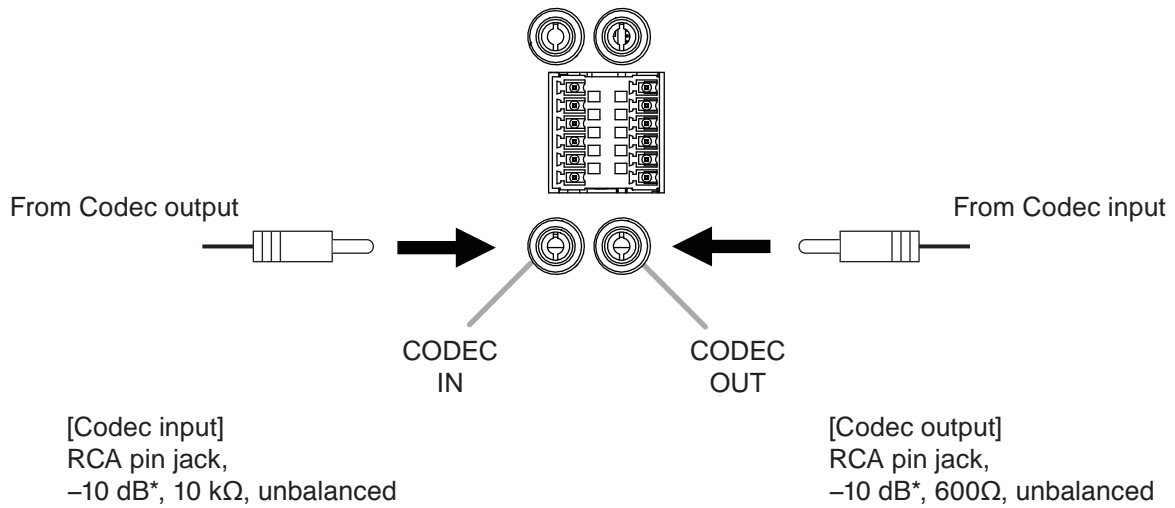

* 0 dB = 1 V

7.8. Removable Terminal Plug Connection

Use the removable terminal plugs supplied with the AM-CFI unit to connect the terminals by following the instructions below.

- Be sure to use shielded cables for audio signal lines.
- Avoid soldering cable conductor, as contact resistance may increase when the cable is tightened and the solder is crushed, possibly resulting in an excessive rise in joint temperatures.
- Use cables of AWG 12 – 24.

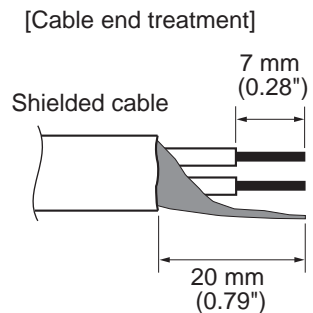

[Terminal plug connections]

Step 1. Loosen the terminal screw, then insert the cable.

Step 2. Retighten the terminal screw. (Pull on the cable to ensure it is securely connected.)

Step 3. Secure the plug and cable with a cable tie or other appropriate band to prevent the cable from coming loose.

Step 4. Insert the plug into the audio output terminal.

Tip

Recommended slotted screwdriver type: Screwdriver with blade that is 3 mm (0.12") in width

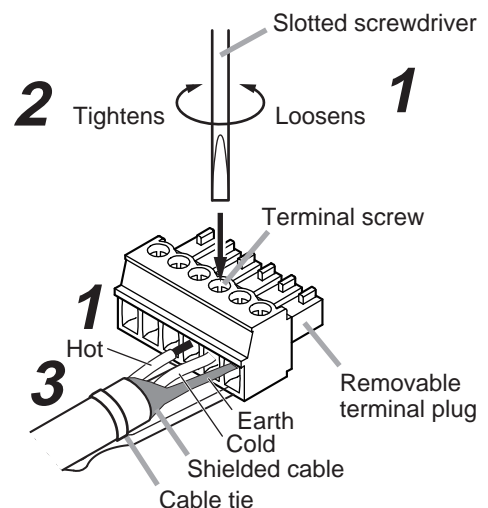

8. SYSTEM SETTINGS

8.1. Overview of System Settings

Connecting the AM-CF1 unit to a PC by way of a LAN cable allows the following function settings and maintenance to be performed using the PC's browser:

[Unit Settings]

- Network settings
- Clock settings
- User account settings

[Operation Settings]

- Volume adjustment and current value confirmation of various audio inputs and outputs
- EQ parameter adjustment
- Settings the range in which the array microphone detects and tracks sound sources
- Echo and noise cancellation settings
- Operation settings for general-purpose control input and output
- Operation setting for the multifunction indicators
- Saving and reading of the above setting data

[Maintenance Function]

- Firmware update

8.2. System Requirements

PC hardware requirements are as follows:

Display	1366 x 768 resolution or higher
---------	---------------------------------

Confirmed PC operation environments are as follows:

OS	Windows 7, 32-bit
	Windows 10, 64-bit
	macOS 10.12 Sierra
Browser	Google Chrome 61.0.3163, Safari 10.1.2

8.3. Connections

Step 1. Start up the web browser and enter "Unit's IP address: 8000" in the address field.

Example: 192.168.14.10: 8000

The login screen is displayed.

Tip: The IP address is factory-preset to "192.168.14.10."

Step 2. Enter a user name and a password.

The menu screen is displayed.



Note

Do not launch multiple web browsers at the same time.

Tip

Default user name and password are as follows:

User name: admin

Password: admin

9. OPERATION

9.1. Turning Power ON and OFF

Connecting an AC adapter or a PoE extender (p. 8) to the AM-CF1 unit turns ON the power. In about approximately 60 seconds, the unit is set to “Normal Operation” mode and can be used. After use, switch the unit to “Power Standby” mode. When using the unit again, switch back to “Normal Operation” mode. Each state of operation is shown as follows by the Power indicator:

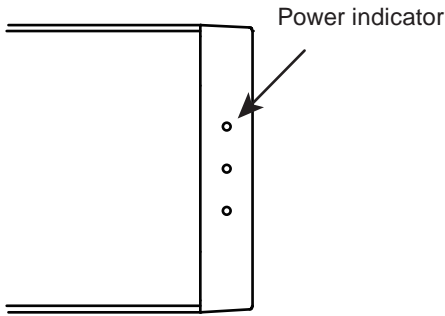

Operating Status		Lighting Status
[When power is ON]	Start processing in progress	Blue ↓ Flashing green ↓ Green
	Unit initialization in progress	Orange
	Normal operation mode	Green
	Power OFF processing in progress	Flashing green ↓ Blue
Power standby mode		Red
Power OFF		Extinguished

9.2. Switching between Power Standby and Normal Operation modes

Step: Hold down the power switch for approximately 3 seconds.
The mode switches between the two.

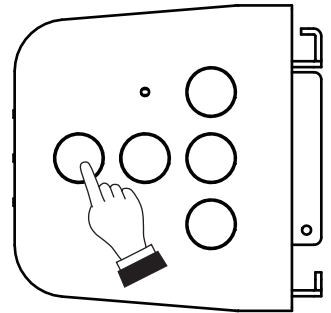

9.3. Turning Power OFF

Turn OFF the power when detaching the AC adapter or PoE extender.

Note

Do not detach the AC adapter or PoE extender from the unit or turn OFF the power of these devices while the power indicator is lit. Doing so could cause the unit’s failure.

Step: Hold down the power switch for approximately 10 seconds.
The power is first set to the Power OFF state and then turns off after approximately 30 seconds.

9.4. Bluetooth Pairing

Step 1. Hold down the Bluetooth Pairing switch for 3 seconds or more.
The Bluetooth indicator flashes.

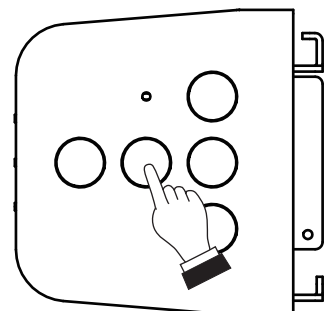
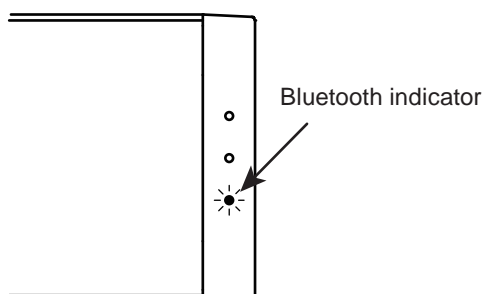

Step 2. Set the peripheral device to be used to pairing mode. After a moment, the Pairing indicator lights.

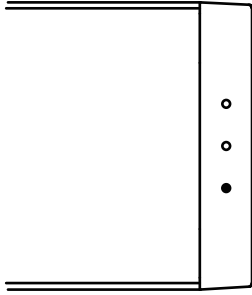

Step 3. Confirm that the unit's name is displayed on the peripheral device screen.
If displayed, this indicates that the Bluetooth connection has begun, and pairing is completed.

Note

To cut off the connection while making the Bluetooth connection, hold down the Bluetooth Paring switch for 3 seconds or more.

9.5. Volume Adjustment

The volume of sound output from the front panel speaker can be adjusted when in Normal Operation mode. While the volume is being adjusted, the current output volume setting state is displayed by the front panel-mounted multifunction indicator.

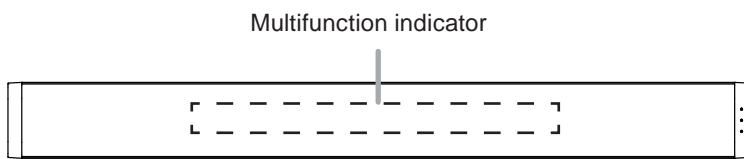

LED Lighting Status	Output Volume Setting Status
●●●●●●●●	0 dB
●●●●●●○	-3 dB
●●●●●○○	-6 dB
●●●●○○○	-9 dB
●●●○○○○	-12 dB
●●○○○○○	-18 dB
●○○○○○○	-24 dB
○○○○○○○	-∞ dB

●: Lit ○: Unlit

Follow the procedure below to adjust the output to an easy-to-hear volume:

Step 1. Press the Volume Up switch to increase the volume.
The number of lit Multifunction Indicator LEDs increases by one with each depression of the switch.

Step 2. Press the Volume Down switch to decrease the volume.
The number of lit Multifunction Indicator LEDs decreases by one with each depression of the switch.

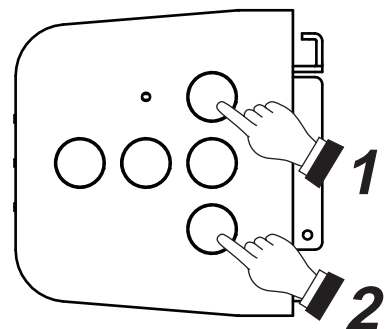

9.6. Microphone Muting

Sound picked up at the microphone can be muted when in Normal Operation mode.

- Step 1.** Press the Mute button.
 Sound picked up by the microphone is silenced.
 The Multifunction indicator continuously lights red during muting.

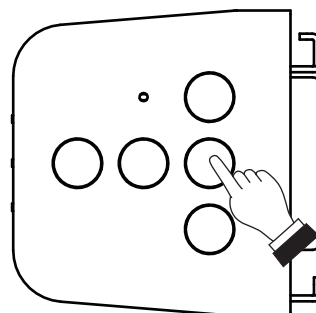
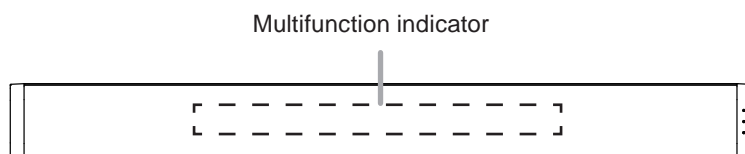

Note: Whether all 7 LEDs or only 1 LED in the center light can be set using the web app. (See p. 11.)

- Step 2.** To disable the mute, press the Mute button again.

10. CONTACT INPUT AND OUTPUT FUNCTIONS

The following functions can be allocated to the contact input and output by PC's browser. To permit external control by connected equipment, short terminals 1 – 2 to the C terminal. For example, when terminals 1 – 2 have been allocated to Preset Memory Nos. 1 – 2 in the contact input settings, shorting individual terminals to the C terminal allows Preset Memory Nos. 1 – 2 to be called up.

- (1) Contact input functions
 - None (unused)
 - Mute (Momentary/Latch)
 - VOL. Up/Down
 - Preset Memory Load
- (2) Contact output functions
 - None (unused)
 - Mute Status
 - Contact Through Out

For details, see p. 11, "SYSTEM SETTINGS."

10.1. Terminal Control Method (Momentary/Latch)

Both momentary type and latch type are available for the terminal control method. Below is the operation diagram for each type of control method.

- Momentary type

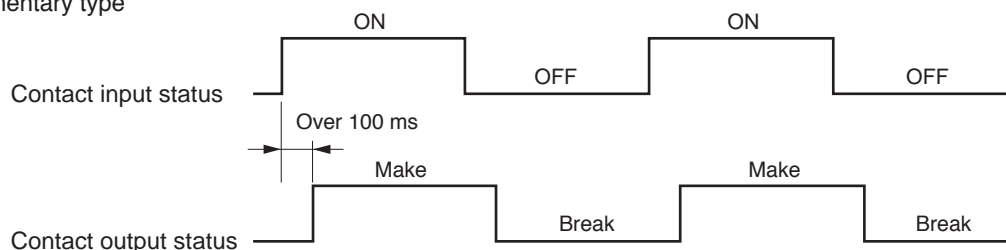

- Latch type

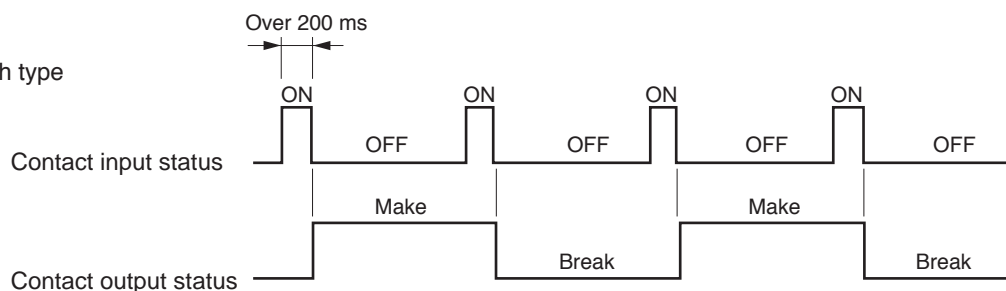

10.2. Contact Input Settings

The following functions can be set for each terminal:

[Mute (Momentary/Latch)]

Mutes sound picked up at the microphone.

The mute/unmute control method differs depending on the settings.

Momentary: Between Mute and Unmute when the terminal is shorted to the C terminal.

Latch: Be set to Mute when the terminal is shorted to the C terminal, and to unmute when opened.

[VOL. Up/Down]

Used to increase or reduce the volume of the AM-CF1 unit's internal speaker. Whenever a terminal is shorted to the C terminal, its gain increases or decreases.

For details, see p. 13, "Volume Adjustment."

[Preset Memory Load]

Accesses the Preset Memory.

Set the Preset Memory (1 – 2) to terminals.

The Preset Memory is accessed when its corresponding terminal is shorted to the C terminal.

If different Preset Memories are assigned to multiple terminals, the last shorted terminal takes precedence.

10.3. Contact Output Settings

The following functions can be set for each terminal:

[Mute Status]

Provides a Make or Break contact depending on microphone mute status.

If the microphone is muted, the contact output terminal is closed.

If the microphone is not muted, the contact output terminal is opened.

[Contact Through Out]

Outputs a Make or Break contact depending on the selection status of the specified contact input terminal.

Set the desired contact input terminal.

If the contact input terminal is closed, the contact output terminal is also closed.

If the contact input terminal is opened, then the contact output terminal is also opened.

11. SPECIFICATIONS

Model Number	AM-CF1B	AM-CF1W	
Power Source	12 V DC (supplied from the specified AC adapter) or 52 V DC (60W PoE (PoE++)) Note: AC adapter not included		
Current Consumption	Under 3.5 A		
Inputs	USB Audio: 2 channels, USB 3.0/USB 2.0/USB 1.1 micro-B port Bluetooth: 2 channels, Codec: 1 channel, RCA pin jack, -10 dB* ¹ , 10 kΩ, unbalanced type AUX: 2 channels, RCA pin jack, -10 dB* ¹ , 10 kΩ, unbalanced type		
Outputs	USB Audio: 2 channels, USB 3.0/USB 2.0/USB 1.1 micro-B port Bluetooth: 2 channels Codec: 1 channel, RCA pin jack, -10 dB* ¹ , 600 Ω, unbalanced type AUX: 2 channels, removable terminal block (6 pins), 4 dB* ² , 600 Ω, balanced (electronically-balanced) type Internal speaker: 2-way x 2 (woofer x 2, tweeter x 1)		
Control Inputs	2 inputs, removable terminal block (6 pins), no-voltage make contact		
Control Outputs	2 outputs, removable terminal block (6 pins), no-voltage make contact, relay contact output		
Network I/F	10BASE-T/100BASE-TX, RJ-45		
Microphone	Unidirectional electret condenser type		
Frequency Characteristics	20 Hz – 20 kHz (AUX IN – AUX OUT)		
Operation Section	Power switch, Bluetooth pairing, Mute, Volume Up/Down		
Indicators	Power (blue/green/orange/red), USB connection (green), Bluetooth (blue), Multifunction (green/red)		
Operating Temperature Range	0 – 40°C		
Operating Humidity Range	90% RH or less (no condensation)		
Finish	Body	Surface-treated aluminium plate, black, 30 % gloss	Surface-treated aluminium plate, white (RAL 9003 equivalent), 30 % gloss
	Punched net	Surface-treated steel plate, black, 30 % gloss	Surface-treated steel plate, white (RAL 9003 equivalent), 30 % gloss
	Side cover	ABS resin, black	ABS resin, white
Dimensions	799 (w) x 83.2 (h) x 85.5 (d) mm (31.46" x 3.28" x 3.37")		
Weight	4.6 kg (10.14 lb)		

*1 0 dB = 1 V

*2 0 dB = 0.775 V

Note: The design and specifications are subject to change without notice for improvement.

• Accessories

Removable terminal plug (6 pins) 2