



REV	DATE	DESCRIPTION	ECO	BY	C'H'K.
B	05/08/2017 00:00:00 AM	LOGO UPDATE	46692	BK	MB

CATALOG NO.	CONDUCTOR		BOLT SIZE	FIG. NO.	DIMENSIONS								INSTALLATION TOOLING (# CRIMPS)											
	CODE (AWG)	NAVY 			B ±.06	C ±.04	H REF.	K DIA. ±.02	L ±.09	N ±.04	O.D. ±.01	T REF.	Z MIN.	DIE INDEX	COLOR CODE	MECHANICAL			HYDRAULIC				DIELESS (# CRIMPS)	WIRE STRIP LENGTH
																MD7-34R MD6	OUR840	Y2MR 	BCT500 Y500CT	Y34A 	Y750 Y35, BAT35 Y39, BAT750	Y46 		
YAZ2CTC38	#2 AWG. [-----]	60		1	1.25 [32]	--		2.40 [61]		.42 [11]		10	BROWN	W2CVT W2CRT (2)	W2CVT W2CRT (2)	-----	W2CVT W2CRT (2)	A2CR (2)	U2CRT (2)	U2CRT (2)	U2CRT (2)	MECHANICAL: MY29-11(1) HYDRAULIC Y644, Y644M BAT644M Y644MBH, Y1000 Y1000BH (1)	1-5/16	
YAZ2CTC38BOX500			3/8 [M10]	1		--	2.40 [61]							W2CVT W2CRT (2)	W2CVT W2CRT (2)									
YAZ2CTC3845				2		1.42 [36]	.40 [10]	2.20 [56]	.41 [10]		.11 [3]													
YAZ2CTC3890				3		1.74 [44]		1.14 [29]																
YAZ2CTC12				1		--		2.65 [67]																
YAZ2CTC1245			1/2 [M12]	2	.73 [19]	1.41 [36]	.52 [13]	2.40 [61]	.53 [13]		.09 [2]			W2CVT W2CRT (2)	W2CVT W2CRT (2)		W2CVT W2CRT (2)	A2CR (2)	U2CRT (2)	U2CRT (2)	U2CRT (2)			
YAZ2CTC1290	#2 AWG. [-----]	60		3	1.25 [32]			1.37 [35]		.42 [11]		10	BROWN	W2CVT W2CRT (2)	W2CVT W2CRT (2)	-----	W2CVT W2CRT (2)	A2CR (2)	U2CRT (2)	U2CRT (2)	U2CRT (2)			

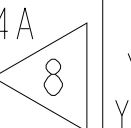
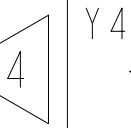
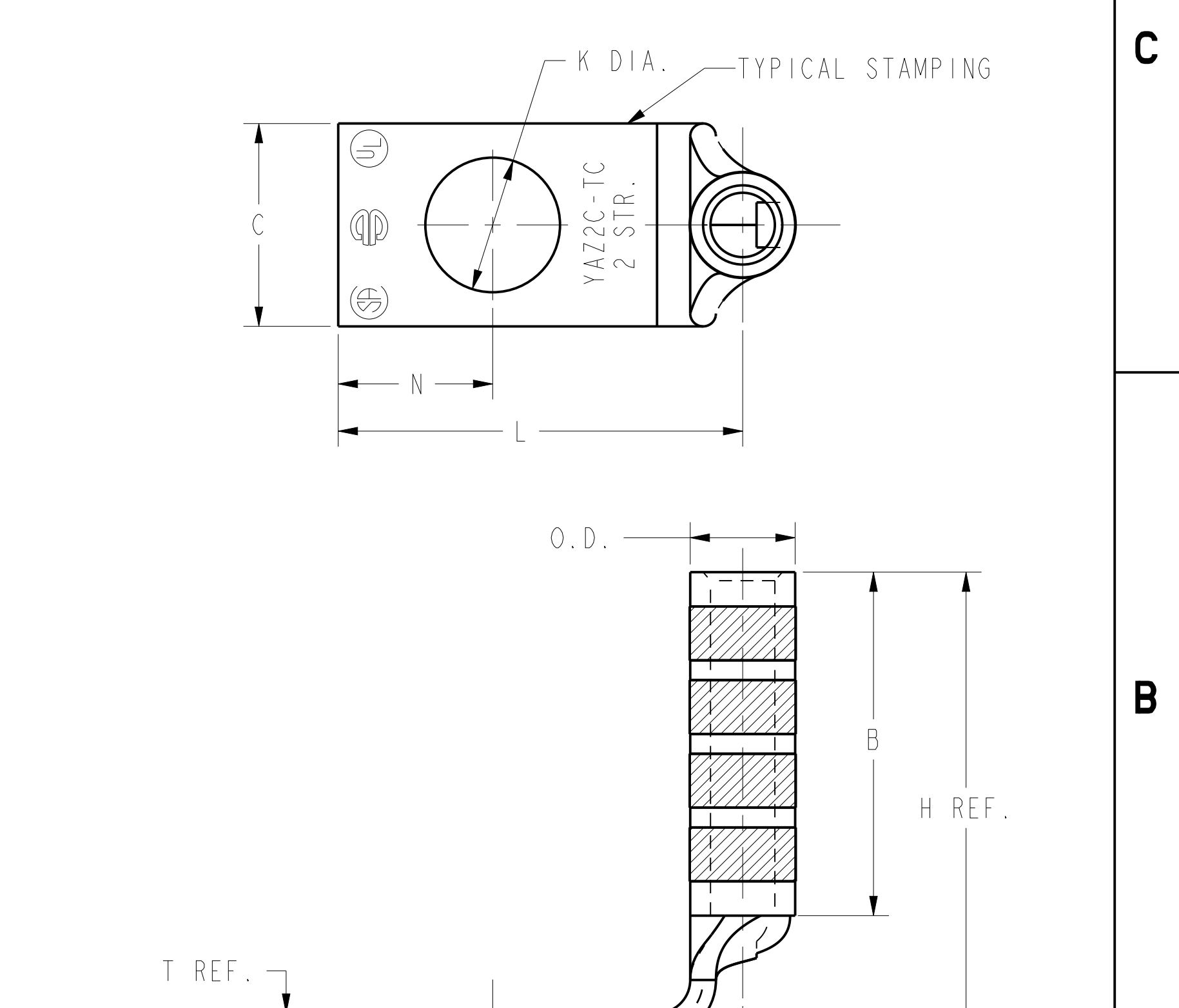
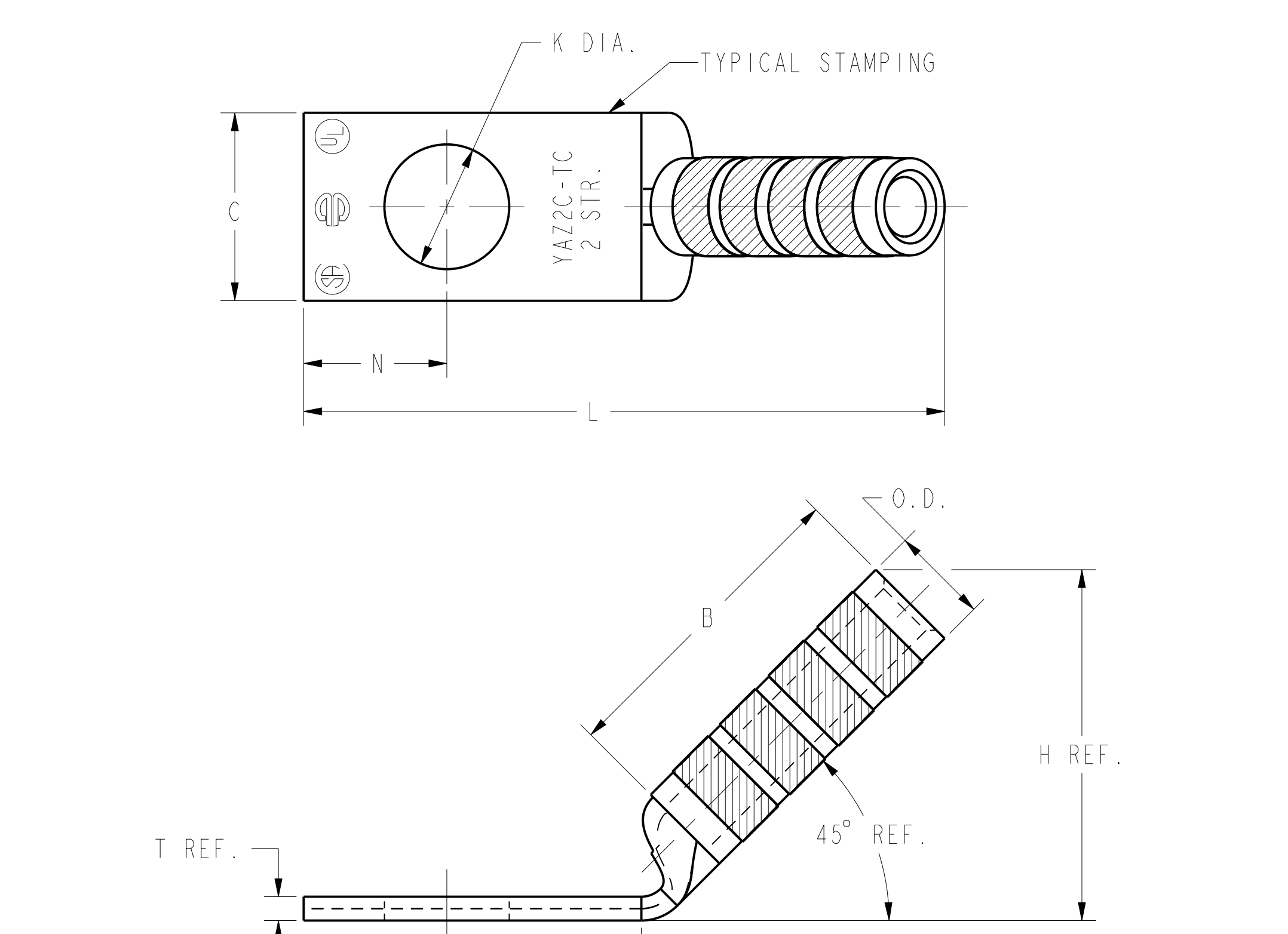
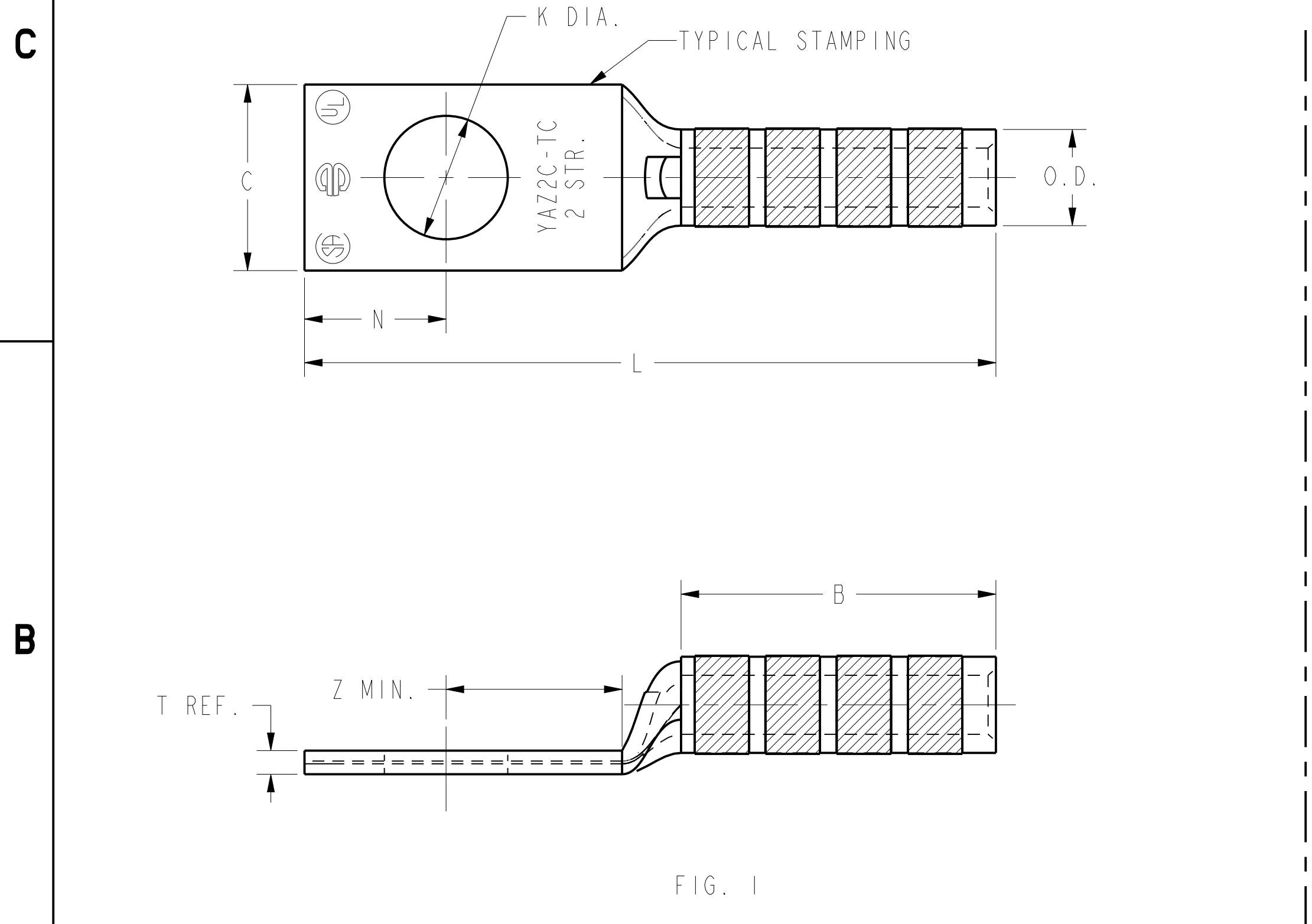

- NOTES:
- MATERIAL: COPPER TUBING.
 - FINISH: TIN PLATED
 - CATALOG # PT6515 ADAPTOR IS REQUIRED TO USE "U" DIES IN Y45 SERIES TOOLS.
 - CATALOG # PUADP-1 ADAPTOR IS REQUIRED TO USE "U" DIES IN Y46 SERIES TOOLS.
 - NAVY CABLE SIZE MAY BE OMITTED ON SOME SIZES BECAUSE OF SPACE LIMITATIONS.
 - PERMANENT DIE IN TOOLING.
 - DIMENSIONS, METRIC WIRE, & METRIC BOLT SIZES IN BRACKETS [] ARE IN MILLIMETERS. DIMENSIONS ARE ROUNDED OFF TO THE NEAREST MILLIMETER, UNLESS OTHERWISE NOTED, AND ARE FOR REFERENCE ONLY.
 - FOR USE BY CUSTOMERS THAT HAVE THIS HYPRESS™. NO NEW Y34A HYPRESS™ TOOLS ARE BEING PROCESSED.

TO ORDER BURNDY® PRODUCTS CALL		HYLUG™ (ONE HOLE CODE)	
UNITED STATES 1-800-346-4175 (LONDONDERRY, NH)		ITEM NO: NA	CAT. NO: YAZ2C-TC- (TABLE)
CANADA: 1-800-361-6975 (QUEBEC) 1-800-387-6487 (ALL OTHER PROVINCES)		DRAWN BY: D.BOISVERT 02/03/2000	CHECKER: R.BOISVERT 01/10/2001
FOR PRODUCT INFO: http://www.burndy.com		DSN APPVL: J.MICHAUD 05/04/2000	MFG APPVL: N/A
		QA APPVL: S.BROWN	MKT APPVL: N/A
		PROD FAM: --	DRAWING NO
		PROJECT #: --	SIZE
		DOCUMENT TYPE: Sales	SE212356
		REL LEVEL: Released	D
		SCALE: NTS	REV
			B
			SHEET 12 OF 40

REV: PE0200

