

REV	DATE	DESCRIPTION	ECO	BY	CHK
G	10/14/2012 00:00:00 AM	CATALOG NUMBERS GAR1926, GAR1929, GAR1934, GAR204C, GAR2026, GAR2029, GAR2034, GAR2039, GAR214C, GAR2126, GAR2129, GAR2134, GAR224C, GAR2226, GAR2229, GAR2234, GAR2426, GAR2429, GAR2434, GAR6439, GAR244C	29104	MM	NJS

CATALOG NUMBER	A						AA						B	Y		J		L		W		"U" BOLT	TORQUE				
	ROD ACCOMMODATED			I.P.S. PIPE ACCOMMODATED			COPPER CONDUCTOR ACCOMMODATED							(in)	(mm)	(in)	(mm)	(in)	(mm)	(in)	(mm)		Lb	in	Nm		
	NOMINAL DIAMETER (in)	ACTUAL DIAMETER		NOMINAL DIAMETER (in)	ACTUAL DIAMETER		AWG			METRIC WIRE SIZE																	
		(in)	(mm)		(in)	(mm)	MIN	MAX	DIA	MIN	MAX	DIA															
GAR1926	2.500-2.88	2.500-2.88	[64]-[73]	2 1/2	2.875	[73]	4 sol	0.204	2/0 str	0.419	25mm ² str	[6.5]	70mm ² str	[10.9]	3.31	[84]	3.19	[81]	3/8	[10]	1.56	[40]	4.19	[106]	266	240	27.0
GAR1929	2.500-2.88	2.500-2.88	[64]-[73]	2 1/2	2.875	[73]	2/0 sol	0.365	250 Kcmil	0.575	70mm ² str	[10.9]	120mm ² str	[14.4]	3.31	[84]	3.19	[81]	3/8	[10]	1.81	[46]	4.19	[106]	266	240	27.0
GAR1934	2.500-2.88	2.500-2.88	[64]-[73]	2 1/2	2.875	[73]	300 Kcmil	0.63	500 Kcmil	0.813	150mm ² str	[16.0]	240mm ² str	[20.3]	3.44	[87]	3.88	[98]	1/2	[13]	2.38	[60]	4.36	[111]	347	480	54.1
GAR204C	3.000-3.50	3.000-3.50	[76]-[89]	3	3.500	[89]	8 sol	0.128	4 str	0.232	10mm ² sol	[3.6]	16mm ² str	[5.1]	3.94	[100]	3.44	[87]	3/8	[10]	1.31	[33]	4.81	[122]	267	240	27.0
GAR2026	3.000-3.50	3.000-3.50	[76]-[89]	3	3.500	[89]	4 sol	0.204	2/0 str	0.419	25mm ² str	[6.5]	70mm ² str	[10.9]	3.94	[100]	3.44	[87]	3/8	[10]	1.56	[40]	4.81	[122]	267	240	27.0
GAR2029	3.000-3.50	3.000-3.50	[76]-[89]	3	3.500	[89]	2/0 sol	0.365	250 Kcmil	0.575	70mm ² str	[10.9]	120mm ² str	[14.4]	3.94	[100]	3.44	[87]	3/8	[10]	1.81	[46]	4.81	[122]	267	240	27.0
GAR2034	3.000-3.50	3.000-3.50	[76]-[89]	3	3.500	[89]	300 Kcmil	0.63	500 Kcmil	0.813	150mm ² str	[16.0]	240mm ² str	[20.3]	4.12	[105]	4.06	[103]	1/2	[13]	2.38	[60]	5.19	[132]	282	480	54.1
GAR2039	3.000-3.50	3.000-3.50	[76]-[89]	3	3.500	[89]	550 Kcmil	0.85	750 Kcmil	0.998	300mm ² str	[22.6]	300mm ² str	[22.6]	4.19	[106]	4.44	[113]	5/8	[16]	2.75	[70]	5.56	[141]	450	660	74.4
GAR214C	3.500-4.00	3.500-4.00	[89]-[102]	3 1/2	4.000	[102]	8 sol	0.128	4 str	0.232	10mm ² sol	[3.6]	16mm ² str	[5.1]	4.44	[113]	3.81	[97]	3/8	[10]	1.31	[33]	5.31	[135]	264	240	27.0
GAR2126	3.500-4.00	3.500-4.00	[89]-[102]	3 1/2	4.000	[102]	4 sol	0.204	2/0 str	0.419	25mm ² str	[6.5]	70mm ² str	[10.9]	4.44	[113]	3.81	[97]	3/8	[10]	1.56	[40]	5.31	[135]	264	240	27.0
GAR2129	3.500-4.00	3.500-4.00	[89]-[102]	3 1/2	4.000	[102]	2/0 sol	0.365	250 Kcmil	0.575	70mm ² str	[10.9]	120mm ² str	[14.4]	4.44	[113]	3.81	[97]	3/8	[10]	1.81	[46]	5.31	[135]	264	240	27.0
GAR2134	3.500-4.00	3.500-4.00	[89]-[102]	3 1/2	4.000	[102]	300 Kcmil	0.63	500 Kcmil	0.813	150mm ² str	[16.0]	240mm ² str	[20.3]	4.56	[116]	4.19	[106]	1/2	[13]	2.38	[60]	5.69	[145]	436	480	54.1
GAR224C	4.000-4.50	4.000-4.50	[102]-[114]	4	4.500	[114]	8 sol	0.128	4 str	0.232	10mm ² sol	[3.6]	16mm ² str	[5.1]	4.94	[126]	3.75	[95]	3/8	[10]	1.31	[33]	5.81	[148]	261	240	27.0
GAR2226	4.000-4.50	4.000-4.50	[102]-[114]	4	4.500	[114]	4 sol	0.204	2/0 str	0.419	25mm ² str	[6.5]	70mm ² str	[10.9]	4.94	[126]	3.75	[95]	3/8	[10]	1.56	[40]	5.81	[148]	261	240	27.0
GAR2229	4.000-4.50	4.000-4.50	[102]-[114]	4	4.500	[114]	2/0 sol	0.365	250 Kcmil	0.575	70mm ² str	[10.9]	120mm ² str	[14.4]	4.94	[126]	3.75	[95]	3/8	[10]	1.81	[46]	5.81	[148]	261	240	27.0
GAR2234	4.000-4.50	4.000-4.50	[102]-[114]	4	4.500	[114]	300 Kcmil	0.63	500 Kcmil	0.813	150mm ² str	[16.0]	240mm ² str	[20.3]	5.06	[129]	4.06	[103]	1/2	[13]	2.38	[60]	6.19	[157]	416	480	54.1
GAR2426	--	--	--	5	5.563	[141]	4 sol	0.204	2/0 str	0.419	25mm ² str	[6.5]	70mm ² str	[10.9]	6.00	[152]	4.06	[103]	3/8	[10]	1.56	[40]	6.88	[175]	422	240	27.0
GAR2429	--	--	--	5	5.563	[141]	2/0 sol	0.365	250 Kcmil	0.575	70mm ² str	[10.9]	120mm ² str	[14.4]	6.00	[152]	4.44	[113]	3/8	[10]	1.81	[46]	6.88	[175]	422	240	27.0
GAR2434	--	--	--	5	5.563	[141]	300 Kcmil	0.63	500 Kcmil	0.813	150mm ² str	[16.0]	240mm ² str	[20.3]	6.12	[156]	4.69	[119]	1/2	[13]	2.38	[60]	7.25	[184]	437	480	54.1
GAR6439	0.625-0.75	0.625-0.75	[16]-[19]	3/8	0.675	[17]	550 Kcmil	0.85	750 Kcmil	0.998	300mm ² str	[22.6]	300mm ² str	[22.6]	1.62	[41]	2.69	[68]	1/2	[13]	2.55	[65]	2.75	[70]	247	480	54.1
GAR244C	-	-	-	5	5.563	[141]	8 sol	0.128	4 str	0.232	10mm ² str	[3.6]	16mm ² sol	[5.1]	1.62	[41]	4.06	[103]	3/8	[10]	1.56	[40]	6.88	[175]	122	240	27.0

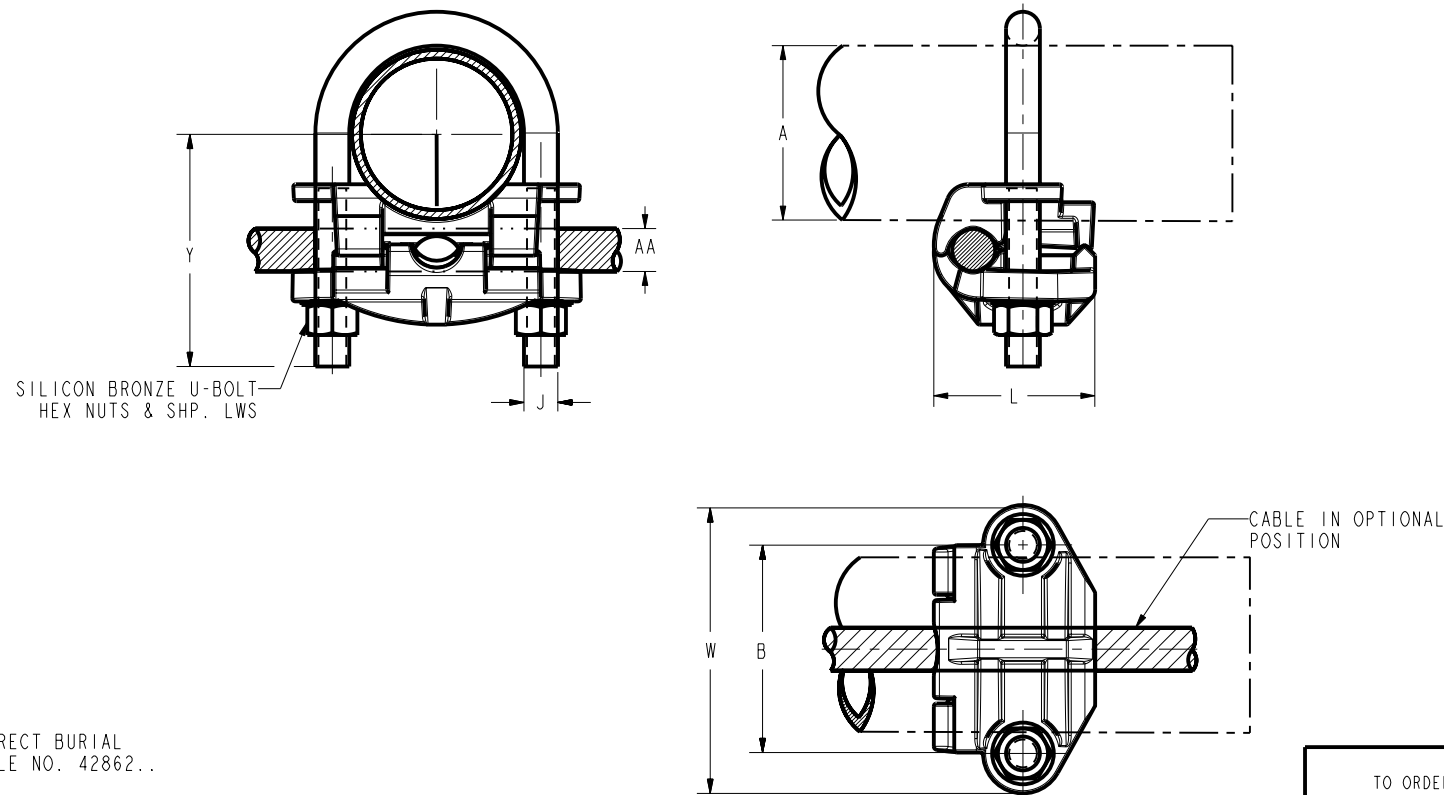

NOTES:

1. MATERIAL: CAST COPPER ALLOY.
2. FINISH: BRIGHT DIPPED.
3. UL 467 LISTED FILE NO. E9999, ACCEPTABLE FOR DIRECT BURIAL IN EARTH AND CONCRETE CSA 22.2 NO 65 LISTED. FILE NO. 42862..
4. DIMENSIONS IN BRACKETS [] ARE IN MILLIMETERS, ROUNDED OFF TO THE NEAREST MILLIMETER, UNLESS OTHERWISE NOTED, AND ARE FOR REFERENCE ONLY.

5. ADD SUFFIX "TN" TO THESE CATALOG NUMBERS FOR TIN-PLATED VERSIONS.
6. ADD SUFFIX "W" TO THESE CATALOG NUMBERS FOR TIN PLATED BODIES AND HARDWARE. HARDWARE TO BE ELECTRO-TIN PLATED.

TO ORDER BURNDY® PRODUCTS CALL		GROUND CLAMP - CABLE TO REBAR	
UNITED STATES 1-800-346-4175 (LONDONDERRY, NH)		ITEM NO: N/A	CAT. NO: GAR-- (TABLE)
CANADA: 1-800-361-6975 (QUEBEC) 1-800-387-6487 (ALL OTHER PROVINCES)		DRAWN BY: B.K. 01/21/09	CHECKER: G.H.G. 01/21/09
FOR PRODUCT INFO: http://www.burndy.com		DSN APPVL: T REYNOLDS 10/18/12	MFG APPVL: --
		QA APPVL: J HILLMAN 10/22/12	MKT APPVL: P THERRIEN 10/19/12
		PROJ #:	SCALE: 1:1
		PROJ TYPE: Sales	PROJ SIZE: SD015789
		REL LEVEL: Released	SHEET 2 OF 4

REV: PEO200

CATALOG NUMBER	A				AA								B		BB		H		J		JJ		W		Y		TORQUE	
	I.P.S. PIPE ACCOMMODATED				COPPER CONDUCTOR ACCOMMODATED								(in)	(mm)	(in)	(mm)	(in)	(mm)	(in)	(mm)	(in)	(mm)	(in)	(mm)	Lb	in	Nm	
	NOMINAL DIAMETER (in)	ACTUAL DIAMETER			AWG				METRIC WIRE SIZE																			
		(in)	(mm)		SIZE	DIA	SIZE	DIA	SIZE	DIA	SIZE	DIA	MIN	MAX	MIN	MAX												
GAR8626	3	6	6.625	[162]	4 sol	0.204	2/0 str	0.419	25mm ² str	[6.5]	70mm ² str	[10.9]	1.25	[32]	1.69	[43]	2.50	[64]	1/2	[13]	3/8	[10]	8.38	[213]	4.88	[124]	480	54.1
GAR8629	3	6	6.625	[162]	2/0 sol	0.365	250 Kcmil	0.575	70mm ² str	[10.9]	120mm ² str	[14.4]	1.25	[32]	1.81	[46]	8.81	[224]	1/2	[13]	3/8	[10]	8.38	[213]	5.16	[131]	480	54.1
GAR8634	3	6	6.625	[162]	300 Kcmil	0.63	500 Kcmil	0.814	150mm ² str	[16.0]	240mm ² str	[20.3]	1.25	[32]	2.06	[52]	8.75	[222]	1/2	[13]	3/8	[10]	8.38	[213]	5.12	[130]	480	54.1

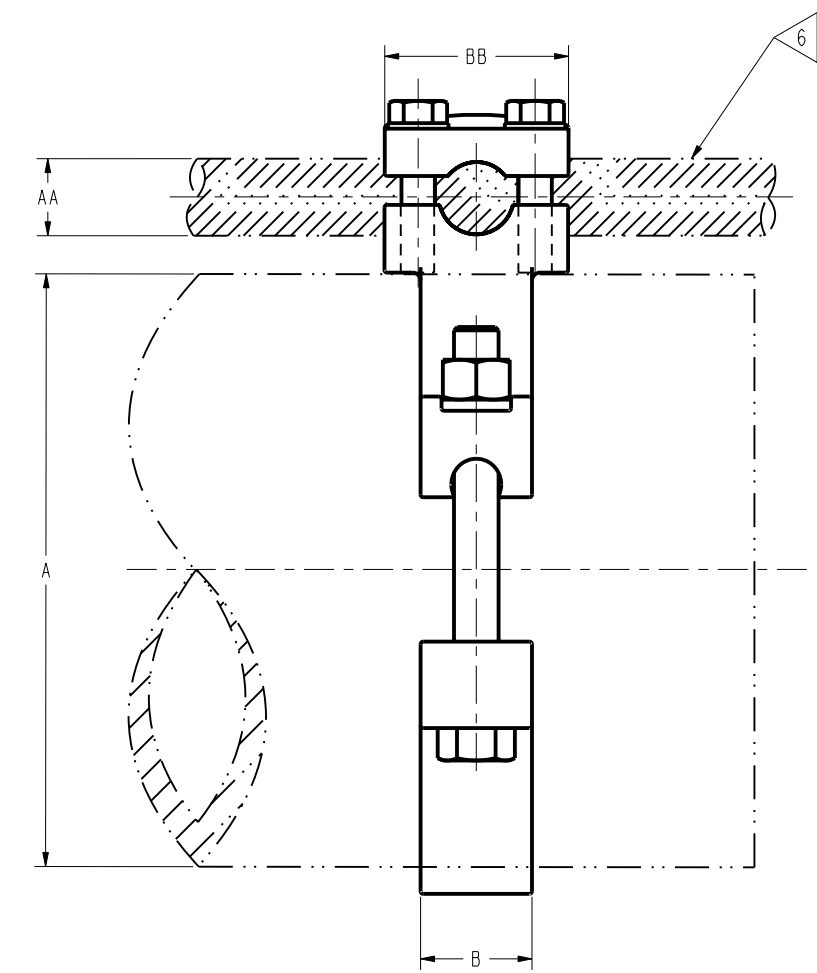
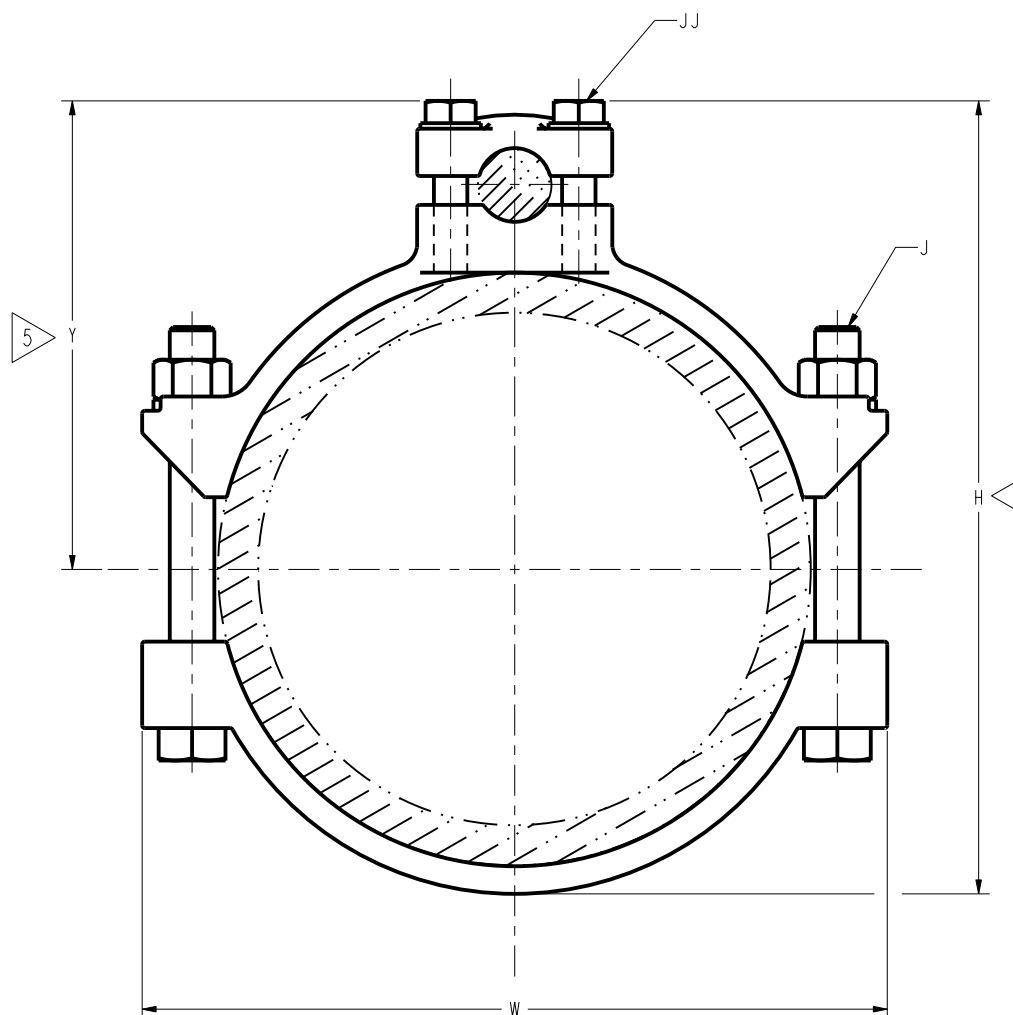

NOTES:

- MATERIAL: CAST COPPER ALLOY.
- FINISH: BRIGHT DIPPED.
- NOT UL LISTED.
- DIMENSIONS IN BRACKETS [] ARE IN MILLIMETERS ROUNDED OFF TO THE NEAREST MILLIMETER, UNLESS OTHERWISE NOTED, AND ARE FOR REFERENCE ONLY.
- MAX. WITH MAX. CABLE IN PLACE BEFORE COMPRESSION.
- CABLE IN OPTIONAL POSITION CAN BE ROTATED 90° FROM POSITION SHOWN.

REV: PE0200

TO ORDER BURNDY® PRODUCTS CALL
 UNITED STATES
 1-800-346-4175 (LONDONDERRY, NH)
 CANADA:
 1-800-361-6975 (QUEBEC)
 1-800-387-6487 (ALL OTHER PROVINCES)
 FOR PRODUCT INFO: <http://www.burndy.com>

GROUND CLAMP - CABLE TO REBAR			
ITEM NO:	N/A		
CAT. NO:	GAR-- (TABLE)		
DRAWN BY:	B.K.	01/21/09	BURNDY
CHECKER:	G.H.G.	01/21/09	
DSN APPVL:	T. REYNOLDS	10/18/12	
MFG APPVL:	--	--	
QA APPVL:	J. HILLMAN	10/22/12	SCALE: 1:1
MKT APPVL:	P. THERRIEN	10/19/12	
PROD FAM:	MECHANICAL GROUNDING	DRAWING NO.	REV
PROJECT #:	--	SIZE	SD015789
DOCUMENT TYPE:	Sales	REL LEVEL:	G
			SHEET 3 OF 4

DRAWING NO.
SD015789

CATALOG NUMBER	CONDUCTOR			CABLE
	TUBE I.P.S.	ROD SIZE or O.D. RANGE	REBAR SIZE	
GAR114C	1/4	1/2	--	8 SOL. - 4 STR.
GAR1126				4 SOL. - 2/0 STR.
GAR1129				2/0 SOL. - 250
GAR644C	3/8	5/8 - 3/4	#5 (5/8") - #6 (3/4")	8 SOL. - 4 STR.
GAR6426				4 SOL. - 2/0 STR.
GAR6429				2/0 SOL. - 250
GAR6434				300-500
GAR144C	1/2 - 3/4	7/8 - 1	#7 (7/8") - #8 (1")	8 SOL. - 4 STR.
GAR1426				4 SOL. - 2/0 STR.
GAR1429				2/0 SOL. - 250
GAR1434				300-500
GAR154C	1	1-1/8 - 1-1/4	#9 (1-1/8") - #10 (1-1/4")	8 SOL. - 4 STR.
GAR1526				4 SOL. - 2/0 STR.
GAR1529				2/0 SOL. - 250
GAR1534				300-500
GAR164C	1-1/4	1-3/8 - 1-1/2	#11 (1-3/8")	8 SOL. - 4 STR.
GAR1626				4 SOL. - 2/0 STR.
GAR1629				2/0 SOL. - 250
GAR1634				300-500

REV	DATE	DESCRIPTION	ECO	BY	C'H'K.
G	10/14/2012 00:00:00 AM	CATALOG NUMBERS: GAR114C, GAR1126, GAR1129, GAR644C, GAR6426, GAR6429, GAR6434, GAR144C, GAR1426, GAR1429, GAR1434, GAR154C, GAR1526, GAR1529, GAR1534, GAR164C, GAR1626, GAR1629, GAR1634	29104	MM	NJS

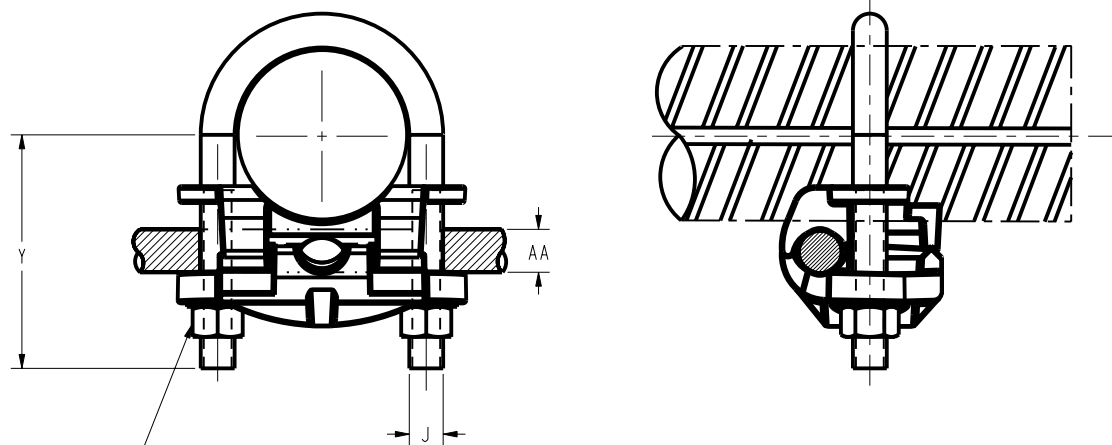

SILICON BRONZE U-BOLT
HEX NUTS & SHP. LWS

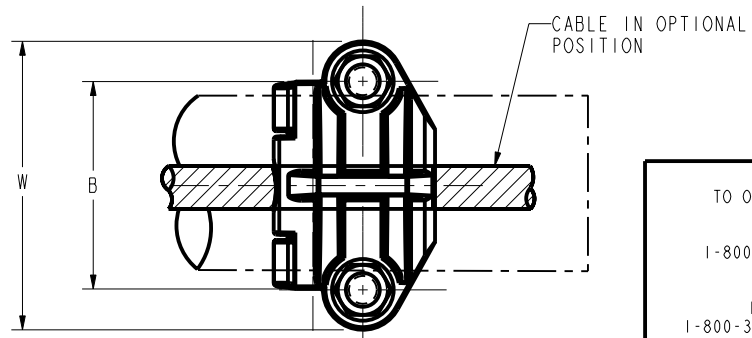

- NOTES:
1. MATERIAL: CAST COPPER ALLOY
 2. FINISH: BRIGHT DIPPED.
 3. UL467 LISTED FILE NO. E9999
ACCEPTABLE FOR DIRECT BURIAL IN EARTH AND CONCRETE.
CSA 22.2 NO 65 LISTED. FILE NO. 42862.
 4. SEE SHEET 1 OF 4 FOR DIMENSIONS.

TO ORDER BURNDY® PRODUCTS CALL
UNITED STATES
1-800-346-4175 (LONDONDERRY, NH)
CANADA:
1-800-361-6975 (QUEBEC)
1-800-387-6487 (ALL OTHER PROVINCES)
FOR PRODUCT INFO: <http://www.burndy.com>

GROUND CLAMP - CABLE TO REBAR	
ITEM NO:	N/A
CAT. NO:	GAR-- (TABLE)
DRAWN BY:	B.K. 01/21/09
CHECKER:	G.H.G. 01/21/09
DSN APPVL:	T. REYNOLDS 10/18/12
MFG APPVL:	--
QA APPVL:	J. HILLMAN 10/22/12
MKT APPVL:	P. THERRIEN 10/19/12
PROD FAM:	MECHANICAL GROUNDING
PROJECT #:	--
DOCUMENT TYPE:	Sales
REL LEVEL:	Released
SCALE:	1:1
DRAWING NO:	SD015789
REV:	G
SHEET 4 OF 4	



REV: PE0200