

DRAWING NO.  
SD089219

PRECRIMP DIE CHART 5

GROUND ROD DIA.	PRECRIMP DIES	
1/2" [12.7]	UPRECRIMP 12	U2CABT
5/8" [15.8]	UPRECRIMP 58	
3/4" [19.1]	UPRECRIMP 34	

REV	DATE	DESCRIPTION	ECO	BY	C'H'K.
A	9/5/2009 12:00:00 AM	REDRAW IN PROE	18993	MB	BSK

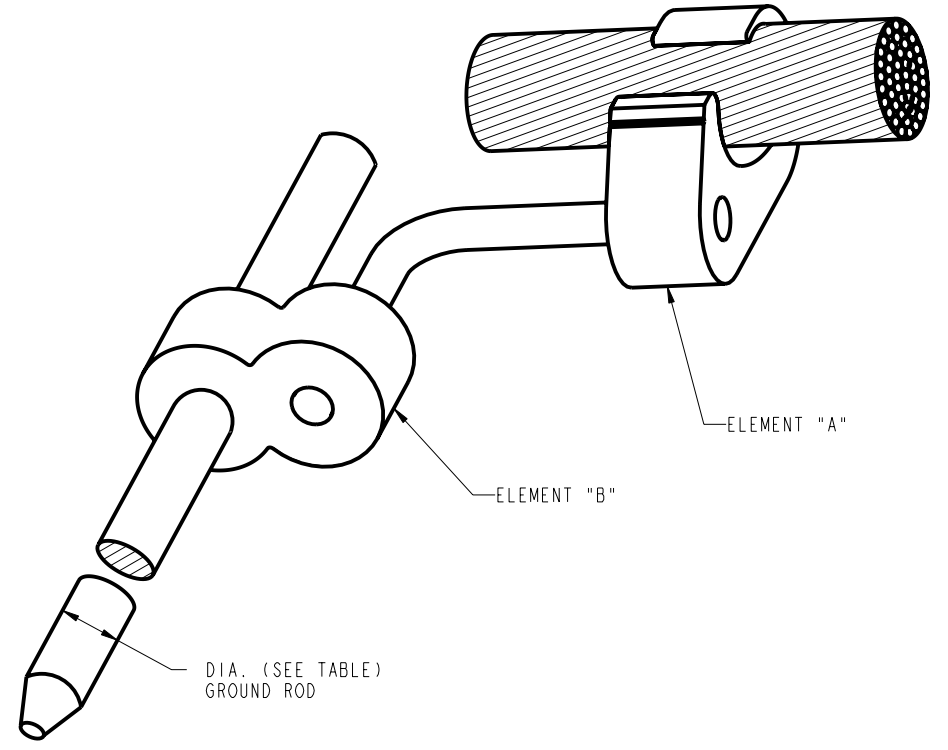
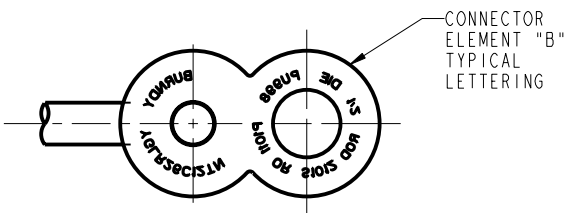
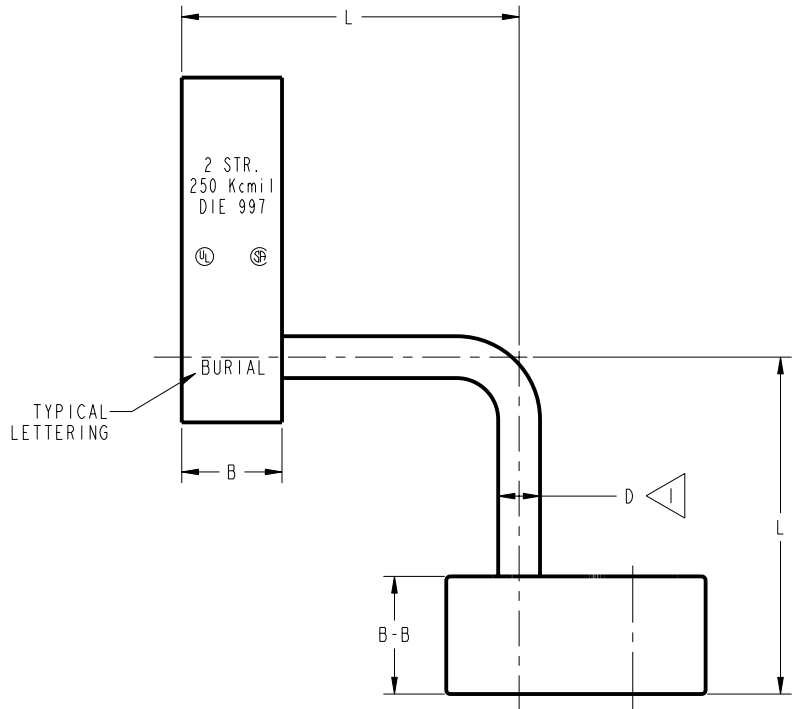
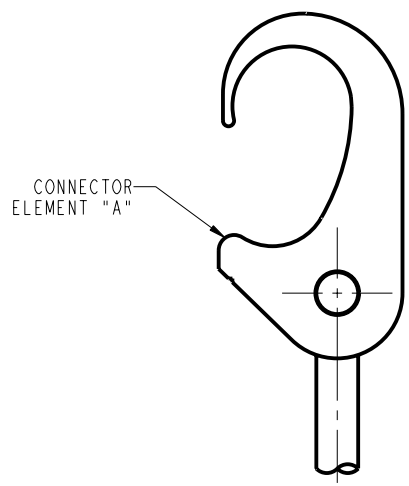

GROUND ROD TO GRID CONNECTION

NOTES:

1. BEFORE CRIMPING, BOTH CONNECTOR ELEMENTS CAN BE TURNED ON ROD DIAMETER "D" TO ANY DESIRED POSITION.
2. GROOVES ARE FILLED WITH PENETROX™.
3. SUITABLE FOR DIRECT BURIAL IN EARTH OR CONCRETE.
4. THE CATALOG NUMBERS SHOWN ARE FOR UNPLATED COPPER CONNECTORS FOR USE ON COPPER CLAD OR STAINLESS STEEL GROUND ROD. TO ORDER ELECTRO-TIN PLATED CONNECTORS FOR USE ON GALVANIZED STEEL GROUND ROD AND SUFFIX "TN" TO THE CATALOG NUMBER, ONLY THE FIGURE 8 CONNECTOR (ELEMENT "B") IS TIN PLATED, THE FIGURE 6 CONNECTOR (ELEMENT "A") IS UNPLATED. NOTE: THE GROUND ROD HOLE DIAMETER IS LARGER FOR GALVANIZED STEEL GROUND ROD IN THE TIN PLATED CONNECTOR.
5. WHEN ATTACHING YGLR TYPE CONNECTORS TO GROUND ROD, GROUND ROD MUST BE EMBOSSED WITH APPROPRIATE PRECRIMP DIE. (SEE TABLE IN UPPER RIGHT-HAND CORNER). FOR CONNECTORS THAT MUST IEEE 837 REQUIREMENTS UPRECRIMP-TYPE PRECRIMP DIES MUST BE USED FOR MAXIMUM CLAMPING RETENTION.
6. WHERE A "U" OR "PU" DIE IS RECOMMENDED WITH THE Y45 HYPRESS™, A PT6515 ADAPTER MUST BE USED.
7. WHERE A "U" OR "PU" DIE IS RECOMMENDED WITH THE Y46 HYPRESS™, A PUADP-1 ADAPTER MUST BE USED.
8. DIMENSIONS IN BRACKET [ ] ARE IN MILLIMETERS.
9. ONLY DIE "1011" APPEARS ON ELEMENT "B" OF THE CONNECTOR.

MATERIAL: HIGH CONDUCTIVITY WROUGHT COPPER

TO ORDER BURNDY® PRODUCTS CALL  
 UNITED STATES  
 1-800-346-4175 (LONDONDERRY, NH)  
 CANADA:  
 1-800-361-6975 (QUEBEC)  
 1-800-387-6487 (ALL OTHER PROVINCES)  
 FOR PRODUCT INFO: <http://www.burndy.com>

GROUND ROD CONNECTOR	
ITEM NO:	N/A
CAT. NO:	YGLR--C-- (TABLE)
DRAWN BY:	C RACCANO 03/26/84
CHECKER:	AJM 05/23/84
DSN APPVL:	ESR 05/23/84
MFG APPVL:	--
QA APPVL:	--
MKT APPVL:	--
PROD FAM:	--
PROJECT #:	--
DOCUMENT TYPE:	Sales
REL LEVEL:	Released
SCALE:	1:1
DRAWING NO:	SD089219
REV:	A
SHEET 1 OF 2	



REV: PE0200

DRAWING NO.  
SD089219

7

6

5

4

3

2

1

REV	DATE	DESCRIPTION	ECO	BY	C'H'K.
A	9/5/2009 12:00:00 AM	REDRAW IN PROE	18993	MB	BSK

**NOT FOR PRODUCTION USE**

D

D

C

C

B

B

A

A

REV: PEO200

CATALOG NUMBER	COMMERCIAL COPPER CABLE RANGE ELEMENT "A"	METRIC COPPER CABLE RANGE ELEMENT "A"	COPPER WELD CABLE RANGE ELEMENT "A"	GROUND ROD DIA. ELEMENT "B"	B	B-B	D	L	INSTALLATION TOOLS, DIES SET CAT. NO (NUMBER OF CRIMPS)							
									Y35/Y39 HYPRESS™		Y750 HYPRESS™		Y45 HYPRESS™		Y46 HYPRESS™	
									ELEMENT "A"	ELEMENT "B"	ELEMENT "A"	ELEMENT "B"	ELEMENT "A"	ELEMENT "B"	ELEMENT "A"	ELEMENT "B"
YGLR29C12	#2 STR (.292 DIA) THRU 250 Kcmil (.575 DIA)	35mm <sup>2</sup> (7.6mm DIA) THRU 120mm <sup>2</sup> (14.4mm DIA)	91.65 Kcmil (.343 DIA) THRU 248.8 Kcmil (.572 DIA)	1/2" [12.7] #3 - #4 REBAR					U997 (1)		U997 (1)		U997 (1)		U997 (1)	
YGLR34C12	250 Kcmil (.575 DIA) THRU 500 Kcmil (.813 DIA)	120mm <sup>2</sup> (14.4mm DIA) THRU 240mm <sup>2</sup> (20.4mm DIA)	248.8 Kcmil (.572 DIA) THRU 498.8 Kcmil (.810 DIA)								.313 [7.9]	2.53 [64.3]	-----		U1011 (2) OR PU998 (1)	
YGLR29C58	#2 STR (.292 DIA) THRU 250 Kcmil (.575 DIA)	35mm <sup>2</sup> (7.6mm DIA) THRU 120mm <sup>2</sup> (14.4mm DIA)	91.65 Kcmil (.343 DIA) THRU 248.8 Kcmil (.572 DIA)	5/8" [15.9] #5 - #6 REBAR					U997 (1)	PU998 (1)	U997 (1)		U997 (1)		U997 (1)	
YGLR34C58	250 Kcmil (.575 DIA) THRU 500 Kcmil (.813 DIA)	120mm <sup>2</sup> (14.4mm DIA) THRU 240mm <sup>2</sup> (20.4mm DIA)	248.8 Kcmil (.572 DIA) THRU 498.8 Kcmil (.810 DIA)										.75 [19.1]		.88 [22.4]	
YGLR29C34	#2 STR (.292 DIA) THRU 250 Kcmil (.575 DIA)	35mm <sup>2</sup> (7.6mm DIA) THRU 120mm <sup>2</sup> (14.4mm DIA)	91.65 Kcmil (.343 DIA) THRU 248.8 Kcmil (.572 DIA)	3/4" [19.1] #5 - #6 REBAR					U997 (1)		U997 (1)		U997 (1)		U997 (1)	
YGLR34C34	250 Kcmil (.575 DIA) THRU 500 Kcmil (.813 DIA)	120mm <sup>2</sup> (14.4mm DIA) THRU 240mm <sup>2</sup> (20.4mm DIA)	248.8 Kcmil (.572 DIA) THRU 498.8 Kcmil (.810 DIA)										.500 [12.7]		2.63 [66.8]	
YGLR29C100	#2 STR (.292 DIA) THRU 250 Kcmil (.575 DIA)	35mm <sup>2</sup> (7.6mm DIA) THRU 120mm <sup>2</sup> (14.4mm DIA)	91.65 Kcmil (.343 DIA) THRU 248.8 Kcmil (.572 DIA)	1" [25.4] #6 - #7 REBAR					-----		U997 (1)		U997 (1)		U997 (1)	
YGLR34C100	250 Kcmil (.575 DIA) THRU 500 Kcmil (.813 DIA)	120mm <sup>2</sup> (14.4mm DIA) THRU 240mm <sup>2</sup> (20.4mm DIA)	248.8 Kcmil (.572 DIA) THRU 498.8 Kcmil (.810 DIA)													

TO ORDER BURNDY® PRODUCTS CALL		GROUND ROD CONNECTOR	
UNITED STATES 1-800-346-4175 (LONDONDERRY, NH)		ITEM NO: N/A	SCALE: 1:1
CANADA: 1-800-361-6975 (QUEBEC) 1-800-387-6487 (ALL OTHER PROVINCES)		CAT. NO: YGLR--C-- (TABLE)	REV
FOR PRODUCT INFO: <a href="http://www.burndy.com">http://www.burndy.com</a>		DRAWN BY: C RACCANO 03/26/84	DRAWING NO
		CHECKER: AJM 05/23/84	SD089219
		DSN APPVL: ESR 05/23/84	A
		MFG APPVL: --	SHEET 2 OF 2
		QA APPVL: --	
		MKT APPVL: --	
		PROJ APPVL: --	
		PROJECT #: --	
		DOCUMENT TYPE: Sales	
		REL LEVEL: Concept	

8

7

6

5

4

3

2

1