



Datasheet: Transceiver

SFP-H10GB-ACUXM

11GBd Active Copper SFP+ (Small Form Pluggable) Transceiver

Key Features

- Up to 11 GBd bi-directional data links
- 24AWG through 30 AWG cable available
- Dual SFP+ Connectors
- Industry standard small form pluggable (SFP+) package
- Spans up to 15 meters
- Hot Pluggable
- Single power supply 3.3V
- RoHS Compliance
- Operating temperature range: 0°C to 70°C

Applications

- 10G Ethernet
- 10G Fibre Channel

Ordering Information

Part number	Description
SFP-H10GB-ACUxM	11GBd Active Copper SFP+

Introduction

SFP-H10GB-ACUXM Overview

PROLABS's SFP-H10GB-ACUXM Active Copper SFP+ transceivers are designed for operation in short connection using Fiber Channel and 10G Ethernet networking equipment. It is integrated with Amphenol Spectra Strip SkewClear cable, the completed assembly spans 15 meters and operates up to 11GBd. The transmitter pre-emphasis can be configured to best compensate for different cable lengths. Active copper assemblies are typically used in host systems that do not employ EDC

Compatible Ordering Information

Base code	OEM Vendor	Prolabs Ordering SKU	Product Description
SFP-H10GB-ACU0.5M	Generic	ACU0.5M-SFP-10G-C	10G SFP+ Active Cable 0.5m
	HP Server	487649-B21-C	10G SFP+ Active Cable 0.5m
SFP-H10GB-ACU10M	Avaya	AA1403018-C	10G SFP+ Active Cable 10m



Datasheet Transceiver

	BTN/IBM	90Y9436-C	10G SFP+ Active Cable 10m
	Cisco	SFP-H10GB-ACU10M-C	10G SFP+ Active Cable 10m
	F5 Networks	F5-UPG-SFPC+-10M-C	10G SFP+ Active Cable 10m
	Fortinet	SP-CABLE-ADASFP+10M-C	10G SFP+ Active Cable 10m
	Generic	ACU10M-SFP-10G-C	10G SFP+ Active Cable 10m
	HP ProCurve	J9286B-C	10G SFP+ Active Cable 10m
	Huawei	SFP-H10G-AC10M-C	10G SFP+ Active Cable 10m
	Intel	XDACBL10M-C	10G SFP+ Active Cable 10m
	Juniper	EX-SFP-10GE-DAC-10M-C	10G SFP+ Active Cable 10m
		QFX-SFP-DAC-10MA-C	10G SFP+ Active Cable 10m
	ZTE	SFP+-Cable-10M-C	10G SFP+ Active Cable 10m
SFP-H10GB-ACU1M	Brocade	10G-SFPP-TWX-0101-C	10G SFP+ Active Cable 1m
	BTN/IBM	95Y0323-C	10G SFP+ Active Cable 1m
	Cisco	SFP-H10GB-ACU1M-C	10G SFP+ Active Cable 1m
	F5 Networks	F5-UPG-SFPC+-1M-C	10G SFP+ Active Cable 1m
	Fortinet	SP-CABLE-ADASFP+1M-C	10G SFP+ Active Cable 1m
	Generic	ACU1M-SFP-10G-C	10G SFP+ Active Cable 1m
	HP Server	487652-B21-C	10G SFP+ Active Cable 1m
	Juniper	QFX-SFP-DAC-1MA-C	10G SFP+ Active Cable 1m
SFP-H10GB-ACU2M	Brocade	10G-SFPP-TWX-0201-C	10G SFP+ Active Cable 2m
SFP-H10GB-ACU3M	Avaya	AA1403019-C	10G SFP+ Active Cable 3m
	Brocade	10G-SFPP-TWX-0301-C	10G SFP+ Active Cable 3m
	BTN/IBM	95Y0326-C	10G SFP+ Active Cable 3m
	Cisco	SFP-H10GB-ACU3M-C	10G SFP+ Active Cable 3m
	F5 Networks	F5-UPG-SFPC+-3M-C	10G SFP+ Active Cable 3m
	Fortinet	SP-CABLE-ADASFP+3M-C	10G SFP+ Active Cable 3m
	Generic	ACU3M-SFP-10G-C	10G SFP+ Active Cable 3m
	HP Server	487655-B21-C	10G SFP+ Active Cable 3m
	Juniper	QFX-SFP-DAC-3MA-C	10G SFP+ Active Cable 3m
SFP-H10GB-ACU5M	Avaya	AA1403020-C	10G SFP+ Active Cable 5m
	Brocade	10G-SFPP-TWX-0501-C	10G SFP+ Active Cable 5m
	BTN/IBM	95Y0329-C	10G SFP+ Active Cable 5m
	Cisco	SFP-H10GB-ACU5M-C	10G SFP+ Active Cable 5m
	F5 Networks	F5-UPG-SFPC+-5M-C	10G SFP+ Active Cable 5m
	Fortinet	SP-CABLE-ADASFP+5M-C	10G SFP+ Active Cable 5m
	Generic	ACU5M-SFP-10G-C	10G SFP+ Active Cable 5m
	Juniper	QFX-SFP-DAC-5MA-C	10G SFP+ Active Cable 5m
SFP-H10GB-ACU7M	Brocade	10G-SFPP-TWX-0701-C	10G SFP+ Active Cable 7m
	Cisco	SFP-H10GB-ACU7M-C	10G SFP+ Active Cable 7m
	F5 Networks	F5-UPG-SFPC+-7M-C	10G SFP+ Active Cable 7m
	Fortinet	SP-CABLE-ADASFP+7M-C	10G SFP+ Active Cable 7m
	Generic	ACU7M-SFP-10G-C	10G SFP+ Active Cable 7m
	HP Server	487658-B21-C	10G SFP+ Active Cable 7m
	Huawei	SFP-H10G-AC7M-C	10G SFP+ Active Cable 7m
	Intel	XDACBL7M-C	10G SFP+ Active Cable 7m
	Juniper	EX-SFP-10GE-DAC-7M-C	10G SFP+ Active Cable 7m
		QFX-SFP-DAC-7MA-C	10G SFP+ Active Cable 7m
	ZTE	SFP+-Cable-7M-C	10G SFP+ Active Cable 7m

Speciifcation

Product Selection

SFP-H10GB-ACUXM		SFP-H10GB-ACUXM	
CABEL LENGTH	X	CABLE LENGTH	X
7M	7	10M	10

Absolute Maximum Ratings



Parameter	Symbol	Min	Typical	Max	Unit	Remarks
Storage Temperature		40		85	*C	
Supply Voltage	Bs	-0.5		6	V	
Operating Current	Lop			400	mA	
Relative Humidity	RH	0		85	%	non-condensing

General Specifications

Parameter	Symbol	Min	Typical	Max	Unit	Remarks
Data Rate	DR	0.155		11	GBd	
Bit Error Rate	BER			10 ⁻¹²		
Case Operating Temp	T _{OP}	0		70	*c	
Supply Voltage	V _{CC}	3.15	3.3	3.6	V	
Supply Current	I _{CC}		100	300	Ma	

Electrical Characteristics - Transmitter

V_{CC}= 3.15 V to 3.6 V, T_{OP} = 0 °C to 70 °C

Parameter	Symbol	Min	Typical	Max	Unit	Remarks
Input differential impedance	R _{IN}			100	Ω	
Transmit Disable Voltage	V _D	V _{CC} -1.5		V _{CC}	V	
Transmit Enable Voltage	V _{EN}	V _{EE}		V _{EE} +0.8	V	
Transmit Disable Assert Time				10	μs	

Electrical Characteristics - Receiver

V_{CC}=3.15V to 3.6V, T_C=0°C to 70°C

Parameter	Symbol	Min	Typical	Max	Unit	Remarks
Single ended data output swing	V _{OUT_PP}	175	300	600	mV	
Data output rise time (20%-80%)	T _R		30		ps	
Data output fall time (20%-80%)	T _F		30		ps	
LOS Fault	V _{LOS_Fault}	2		V _{CC_HOST}	V	
LOS Normal	V _{LOS_normal}	V _{EE}		V _{EE} +0.5	V	

Block Diagram of Transceiver

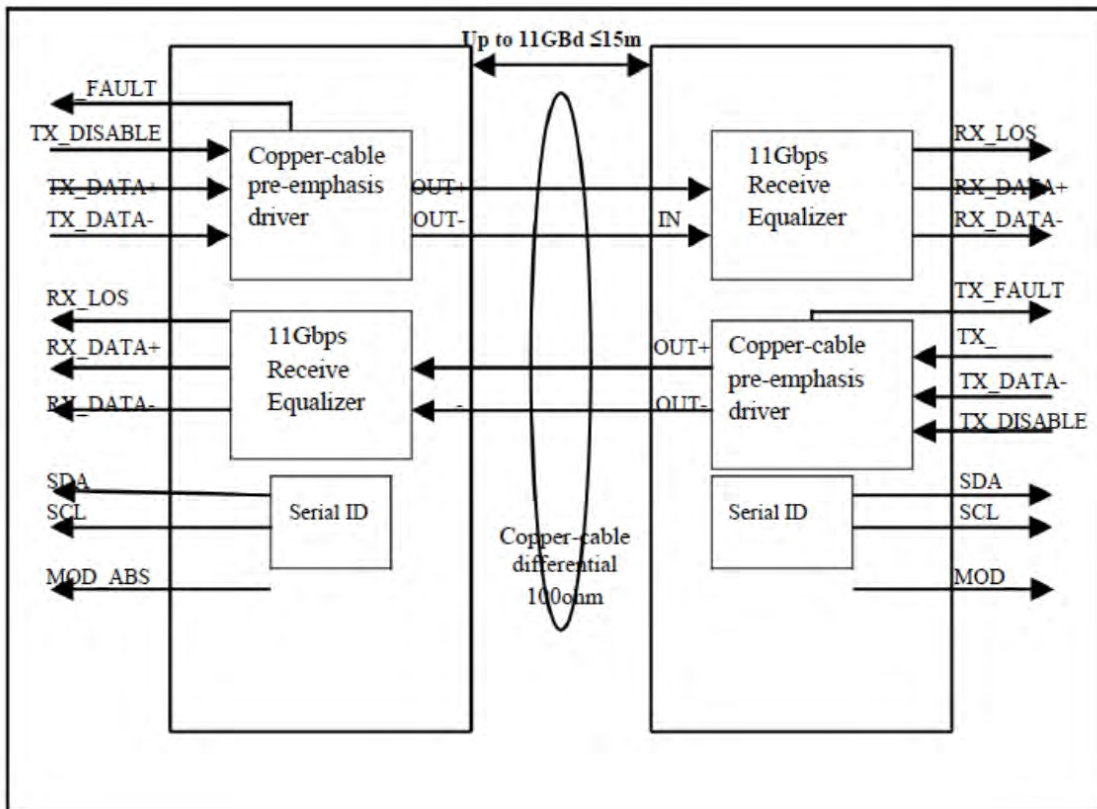

Active cable assembly has signal amplification and equalization in the assembly. Active copper assemblies are typically used in host systems that do not employ EDC. Active SFP+ cable assemblies also incorporate Rx LOS and Tx Disable features.

Active cable assembly has built-in MCU, offer a number of additional host-management capabilities. I2C (Inter-IC bus protocol) interface and on-board EEPROM features enable the host to detect or configure specific performance characteristics.



Datasheet: Transceiver

Dimensions

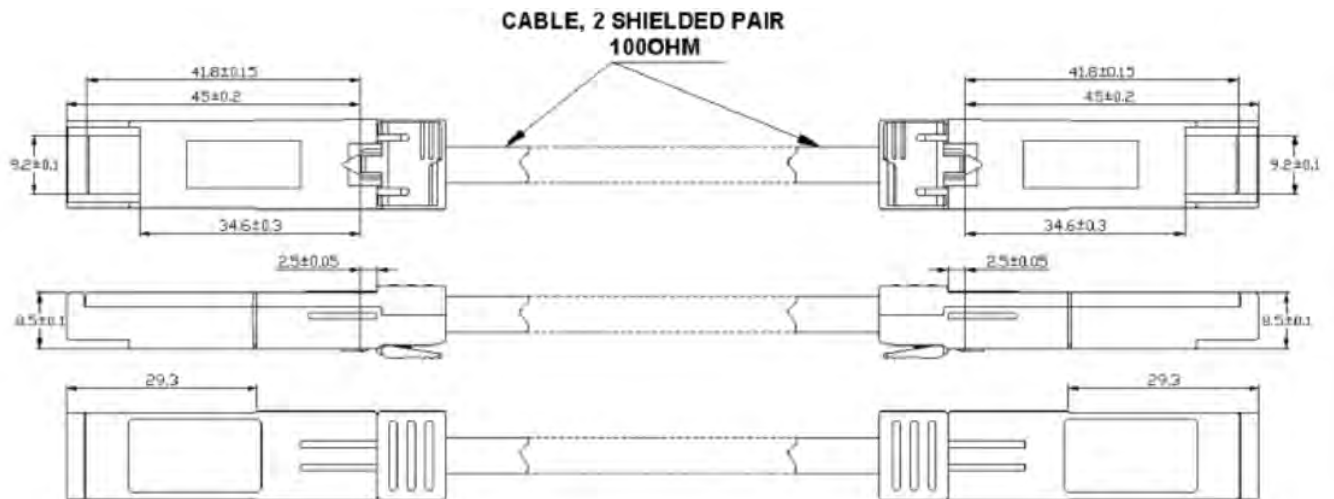

**ALL DIMENSIONS ARE ± 0.2 mm UNLESS OTHERWISE SPECIFIED
UNIT: mm**



Datasheet: Transceiver

Electrical Pad Layout

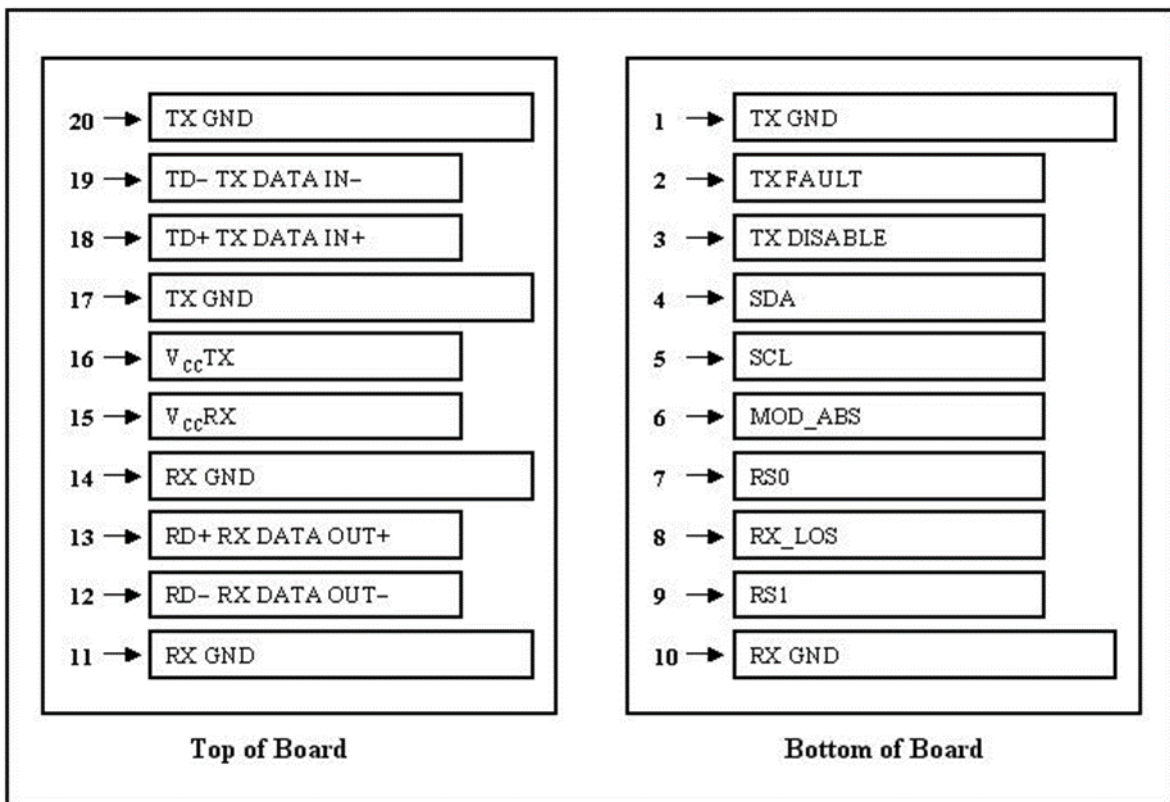
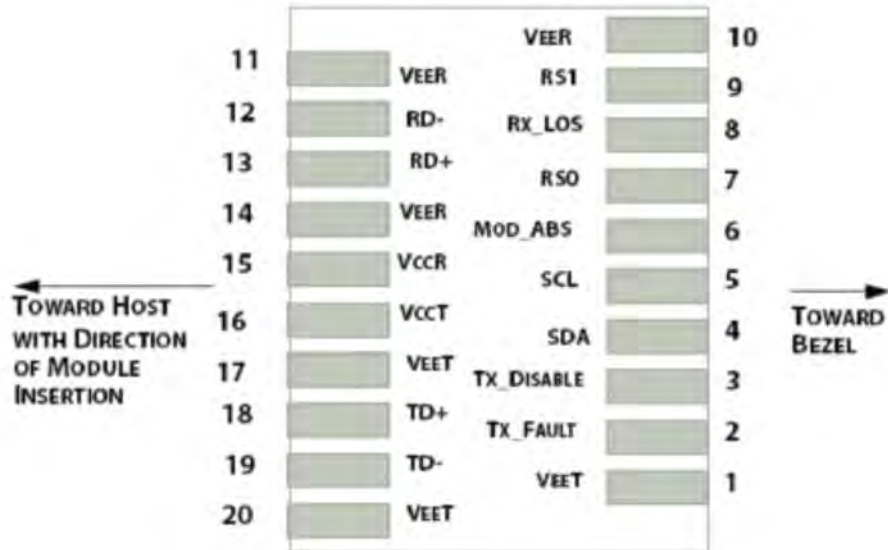



Datasheet: Transceiver

Pin Assignment

PIN#	Symbol	Description	Remarks
1	V _{EET}	Transmitter ground (common with receiver ground)	
2	T _{FAULT}	Transmitter Fault.	
3	T _{DIS}	Transmitter Disable. Laser output disable on high or open	
4	SDA	Data line for serial ID	
5	SCL	Clock line for serial ID	
6	MOD_ABS	Module Absent. Grounded within the module	
7	RS0	No connection required	
8	LOS	Loss of Signal indication. Logic 0 indicates normal operation	
9	RS1	No connection required	
10	V _{EER}	Receiver ground (common with transmitter ground)	
11	V _{EER}	Receiver ground (common with transmitter ground)	
12	RD-	Receiver Inverted DATA out. AC coupled	
13	RD+	Receiver Non-inverted DATA out. AC coupled	
14	V _{EER}	Receiver ground (common with transmitter ground)	
15	V _{CCR}	Receiver power supply	
16	V _{CCT}	Transmitter power supply	
17	V _{EET}	Transmitter ground (common with receiver ground)	
18	TD+	Transmitter Non-Inverted DATA in. AC coupled	
19	TD-	Transmitter Inverted DATA in. AC coupled	
20	V _{EET}	Transmitter ground (common with receiver ground)	

References

1. IEEE standard 802.3ae. IEEE Standard Department, 2005.
2. Enhanced 8.5 and 10 Gigabit Small Form Factor Pluggable Module "SFP+" – SFF-8431 (FC-PH/PH2/PH3).



Datasheet: Transceiver