

# MA/E8/S2/T8

## SOUND MASKING

690 CID Standard Assembly, 4W-70V Rotary Select Transformer, CITY OF CHICAGO-APPROVED



# Quam

### GENERAL DESCRIPTION

The MA/E8/S2/T8 is a 690 CID sound masking loudspeaker assembly consisting of an 8C10PAX - 8" O.D. dual cone loudspeaker with a 10-oz. magnet, and a 4W-70V rotary select transformer. 2 Multi-position hangers included for upward, downward and side firing installations.

### INTENDED USE - Indoor Environment

<b>Installation</b>	Suspended by optional chain kit connected to 2 multi-position hangers between the structural deck and suspended ceiling deck in the following orientations: upwards, downwards or sideways.
<b>Program Material</b>	Equalized Random Noise
<b>Secondary Use</b>	Signal Tones or Voice



### AUDIO SPECIFICATIONS

<b>Average Sensitivity</b>	95 dB-SPL 1W/1M
<b>Loudspeaker Power Rating</b>	20W RMS, EIA 426A Standard
<b>Calculated Output</b>	101 dB SPL, 4W/ 1M
<b>Magnet Type, Weight</b>	BeFe Ceramic, 10 oz
<b>Frequency Response</b>	60 Hz - 17 kHz EIA 426A Standard
<b>Nominal Coverage Angle</b>	90° Included Angle, -6 dB / 2 kHz, Half space
<b>Audio Connection</b>	Pre-cut 7" color coded leads
<b>Mechanical Connection</b>	2 Multi-position hangers

### SYSTEM COMPONENTS

<b>Loudspeaker</b>	8C10PAX
<b>Transformer</b>	70V 4W-5 tap Color code select (4W, 2W, 1W, 0.5W, 0.25W)

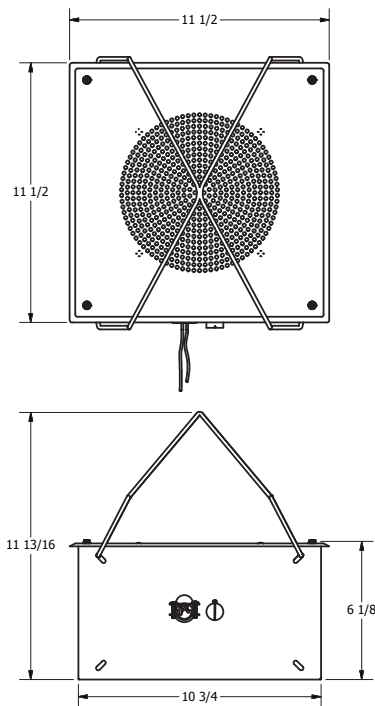

Recommended construction sequences, installation instructions, and A&E Specifications are available in various formats in the Specs and Diagrams section at: [www.QuamSpeakers.com](http://www.QuamSpeakers.com)



QUAM-NICHOLS COMPANY, INC.  
 234 East Marquette Road. Chicago, IL. 60637  
 t: 1-800-NEED-NOW (800-633-3669)  
 f: 1-888-NEED-NOW (888-633-3669)  
 e: [NeedNow@QNC.com](mailto:NeedNow@QNC.com)  
[www.QuamSpeakers.com](http://www.QuamSpeakers.com)

©2017 Quam-Nichols Company reserves the right to make changes and/or improvements to its products at any time and without notice.