

C-TR-A-FP22 Series

LED Flat Panel - 2' x 2'

Replaces 2 x F32T8/U6

C-LITE
LED LIGHTING BY CREE

LOW PROFILE DESIGN, EASY INSTALLATION, FULLY BACKED BY CREE

Reliable, versatile and stylish – that's C-Lite LED Flat Panels. C-Lite LED Flat Panels deliver brighter light and bigger savings, and are fully tested and backed by Cree!



PRODUCT SPECIFICATIONS

OVERVIEW

- Initial Delivered Lumens: 4,000
- CRI: 80
- CCT: Warm White 3500K, Neutral White 4000K, Cool White 5000K
- Mounting: Recessed
- Input Power: 40 Watts
- Dimmable: Yes
- Operating Range: -20°C (-4°F) - 40°C (104°)
- Lifespan: Estimated >100,000 Hours
- Power Factor: > 0.9
- Total Harmonic Distortion: < 20%
- Limited Warranty: 5-Years*
- Replaces 2 x F32T8/U6

FEATURES	BENEFITS	RECOMMENDED USE
<ul style="list-style-type: none">• Pre-installed driver• Powder coated aluminum frame• Opaque white acrylic lens	<ul style="list-style-type: none">• IC Rated for direct contact with insulation• Fits in low-clearance drop ceilings• Fully tested and backed by Cree	<ul style="list-style-type: none">• Offices• Educational & Retail• Commercial & Institutional

ORDERING INFORMATION

Example: C-TR-A-FP22-40L-35K-WH

C-TR-A	FP22	40L		WH
PRODUCT	STYLE	LUMEN PACKAGE	CCT	COLOR
C-TR-A	FP22 Flat Panel 2' x 2'	40L 4,000 Lumens 40W	35K Warm White (3500K) 40K Neutral White (4000K) 50K Cool White (5000K)	WH White

CERTIFICATIONS:

US: c-lite.com T (800) 236-6800 F (262) 504-5415

Canada: www.cree.com/canada T (800) 473-1234 F (800) 890-7507

Rev. Date: V2.04/09/2018

For informational purposes only. Content is subject to change. *See lighting.cree.com/warranty for details



C-TR-A-FP22 Series

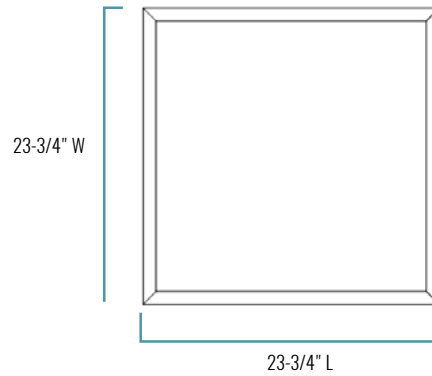

SERIES OVERVIEW

DIMENSIONS	PRODUCT WEIGHT	MOUNTING HEIGHT	SPACING
23-3/4" L x 23-3/4" W x 1/2" H (Panel) 23-3/4" L x 23-3/4" W x 1-3/4" H (w/Driver)	7.6 lbs.	8 to 12 feet	8' x 8' – 10' x 10'

FIXTURE SPECIFICATIONS

HOUSING	Durable aluminum construction White polyester powder-coat Sealed, maintenance-free fixture design
LENS ASSEMBLY	Precision engineered acrylic lens and polystyrene diffuser prevents hot spots, shadows and glare, while providing uniform illumination
MOUNTING	Recessed Installs into conventional grid ceiling Pre-installed driver Requires minimum 90°C supply conductors

ELECTRICAL PERFORMANCE

OPERATING RANGE	LIFESPAN L ₇₀ AT 25°C (77°F)	POWER FACTOR	TOTAL HARMONIC DISTORTION	DIMMABLE
-20°C (-4°F) - 40°C (104°F)	Estimated >100,000 Hours	> 0.9	< 20%	Yes 0-10V
INPUT VOLTAGE	120V	208V	240V	277V
CURRENT DRAW (Amps)	0.33A	0.19A	0.17A	0.14A

WARRANTY & CERTIFICATIONS

WARRANTY	ETL LISTED	DLC
5-Year Limited*	Damp Locations	DLC Qualified

© 2018 Cree, Inc. and/or one of its subsidiaries. All rights reserved. For informational purposes only. Content is subject to change. Patent www.cree.com/patents. C-LITE™ and the C-LITE logo are trademarks of Cree, Inc. The ETL Listed Intertek logo is a trademark of Intertek Testing Services NA, Inc. The DLC QPL logo is a registered trademark of Northeast Energy Efficiency Partnerships, Inc.

US: c-lite.com T (800) 236-6800 F (262) 504-5415

Canada: www.cree.com/canada T (800) 473-1234 F (800) 890-7507

Rev. Date: V2.04/09/2018

For informational purposes only. Content is subject to change. *See lighting.cree.com/warranty for details

C-LITE
LED LIGHTING BY CREE