

2

1

THIS COPY IS PROVIDED ON A RESTRICTED BASIS AND IS NOT TO BE USED IN ANY WAY DETRIMENTAL TO THE INTERESTS OF PANDUIT CORP.

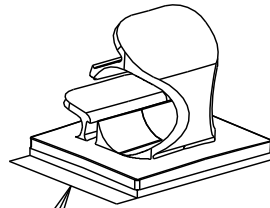
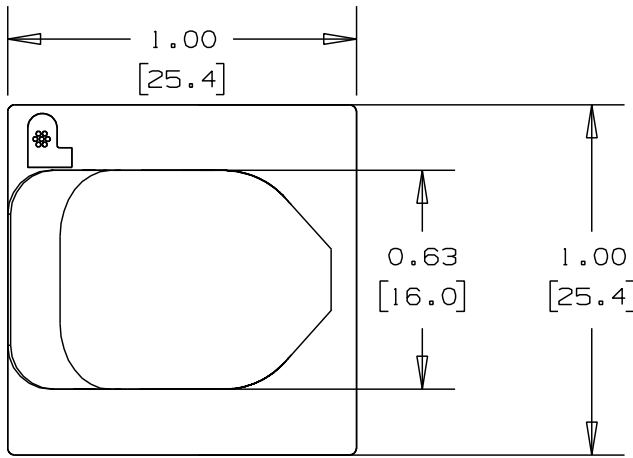

TEAR TAB

FULL SCALE

PANDUIT PART NUMBER*	MAXIMUM CABLE DIA. in. (mm)	WEIGHT lbs. (g)/100pcs
LWC38-A	0.38 (9.6)	0.64 (292)

NOTES:

- *1) SEE www.panduit.com FOR CURRENT PART NUMBER SUFFIX DESIGNATION AND FOR PACKAGE SIZE AND PART COLOR.
- 2) MOUNT IS DESIGNED TO SUPPORT 0.50 lbs (227g) MAX WEIGHT ON A CLEAN DRY SMOOTH SURFACE.

- TO APPLY LATCHING WIRE CLIP:
1. REMOVE PROTECTIVE LINER
 2. PLACE IN DESIRED LOCATION
 3. APPLY PRESSURE TO TOP OF LATCHING WIRE CLIP

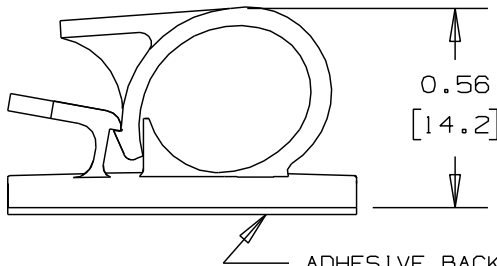

ADHESIVE BACKING: PRESSURE SENSITIVE FOAM 0.04 (1.0) THICK WITH PROTECTIVE LINER TO EXTEND BEYOND EDGE FORMING A TEAR TAB.

NO WARRANTY, EXPRESSED OR IMPLIED, IS MADE BY PANDUIT WITH RESPECT TO ADHESIVE BOND PERFORMANCE, AMONG OTHER THINGS, THE CONDITIONS UNDER WHICH THESE MOUNTS MAY BE APPLIED, AND/OR THE SURFACE TO WHICH THEY MAY BE APPLIED, ARE BEYOND PANDUIT'S CONTROL.

DIMENSIONS IN BRACKETS ARE METRIC (mm)

REV	DATE	BY	CHK	APR	DESCRIPTION	ECN
2	8/05/13	BWG	MPH	RTFI	REVISED MAX. CABLE DIA. AND REVISED NOTE 1	GB0160BA/02
2	8/05/13	BWG	MPH	RTFI	AND REVISED TITLE BORDER.	GB0160BA/02

TITLE		LWC38-A, LATCHING WIRE CLIP		
CUSTOMER DRAWING				
ITEM REVISION NAME		10B015KH/00		
DATASET FILE NAME		10B015KH_DC/00 - GB0160BA_REV02		
UNLESS OTHERWISE SPECIFIED, DIMENSIONAL TOLERANCES ARE: IN (mm)				
.x ± 0.05 (1.3) .xxx ± 0.010 (0.25) .xx ± 0.02 (0.5) ANGLES ± 5°				
DRAWING NUMBER:		GB0160BA		
DRAWN BY	DATE	CHK	SCALE	SIZE
JRL	11-11-93		2X	A
SHT 1 OF 1				

2

1

D101000A/16