

THIS COPY IS PROVIDED ON A RESTRICTED BASIS AND IS NOT TO BE USED IN ANY WAY DETRIMENTAL TO THE INTERESTS OF PANDUIT CORP.

PART NO.	DESCRIPTION	SINGLE HINGE FRONT DOOR	SPLIT REAR DOOR	SPLIT SIDE PANEL	ADJUSTABLE FRONT UTILITY E-RAILS	REAR CAGE NUT FINGER MGMT E-RAILS	STANDARD PDU BRACKETS	CASTERS	CABLE MGMT FINGERS	CABINET WEIGHT FULLY UNPACKAGED	CABINET WEIGHT SHIPPING WEIGHT
S8212*A	NET-ACCESS S-TYPE CABINET 800mm X 42RU X 1070mm DEEP	01	01	02	02	02	00	04	01	142 Kg/EACH 315 LBS/EACH	163 Kg/EACH 360 LBS/EACH
S8512*A	NET-ACCESS S-TYPE CABINET 800mm X 45RU X 1070mm DEEP	01	01	02	02	02	00	04	01	149 Kg/EACH 330 LBS/EACH	170 Kg/EACH 375 LBS/EACH
S8812*A	NET-ACCESS S-TYPE CABINET 800mm X 48RU X 1070mm DEEP	01	01	02	02	02	00	04	01	156 Kg/EACH 345 LBS/EACH	176 Kg/EACH 390 LBS/EACH
S8219*A	NET-ACCESS S-TYPE CABINET 800mm X 42RU X 1070mm DEEP	01	01	00	02	02	00	04	01	120 Kg/EACH 265 LBS/EACH	140 Kg/EACH 310 LBS/EACH
S8519*A	NET-ACCESS S-TYPE CABINET 800mm X 45RU X 1070mm DEEP	01	01	00	02	02	00	04	01	127 Kg/EACH 280 LBS/EACH	147 Kg/EACH 325 LBS/EACH
S8819*A	NET-ACCESS S-TYPE CABINET 800mm X 48RU X 1070mm DEEP	01	01	00	02	02	00	04	01	133 Kg/EACH 295 LBS/EACH	154 Kg/EACH 340 LBS/EACH

* DENOTES COLOR
 "B" = BLACK
 "W" = WHITE

REV	DATE	BY	CHK	APR	DESCRIPTION	ECN
01A	11-26-14	PBS	ADP	TCN	SEE SHEET 1 OF 5 FOR REVISIONS	V09000BX
00A	6-06-13	MDCA	PBS	JDWE	SEE SHEET 1 OF 5 FOR REVISIONS	12V352BS-DC

TITLE		NET-ACCESS S TYPE UTILITY CABINET 800mm WIDE X 1070mm DEEP FAMILY	
		CUSTOMER DRAWING	
ITEM REVISION NAME		12V352BS/01.PRT	
DATASET FILE NAME		12V352BS_DC/01A.PRT	
		MATERIAL:	
		N/A	
		DRAWING NUMBER:	
		12V352BS-DC	
DRAWN BY		DATE	CHK
MDCA	6-06-13	PBS	SCALE
		NONE	
SHT 2 OF 5		SIZE	
		A	

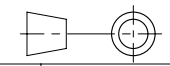

THIRD ANGLE PROJECTION

THIS COPY IS PROVIDED ON A RESTRICTED BASIS AND IS NOT TO BE USED IN ANY WAY DETRIMENTAL TO THE INTERESTS OF PANDUIT CORP.

1115 [43.9]

798
[31.4]

HEIGHT
WITH
CASTERS

42RU
2026
[79.8]

45RU
2159
[85.0]

48RU
2292
[90.2]

1068 [42.0]

TILE COVERAGE
DEPTH

RIGID
FRONT
CASTERS

SWIVEL
REAR
CASTERS

LEFT VIEW

FRONT VIEW

RIGHT VIEW

REAR VIEW

B

B



A

A

01A	11-26-14	PBS	ADP	TCN	SEE SHEET 1 OF 5 FOR REVISIONS	V09000BX
00A	6-06-13	MDCA	PBS	JDWE	SEE SHEET 1 OF 5 FOR REVISIONS	12V352BS-DC
REV	DATE	BY	CHK	APR	DESCRIPTION	ECN

TITLE		NET-ACCESS S TYPE UTILITY CABINET 800mm WIDE X 1070mm DEEP FAMILY	
		CUSTOMER DRAWING	
ITEM REVISION NAME		12V352BS/01.PRT	
DATASET FILE NAME		12V352BS_DC/01A.PRT	
		MATERIAL:	
		N/A	
		DRAWING NUMBER:	
		12V352BS-DC	
DRAWN BY	DATE	CHK	SCALE
MDCA	6-06-13	PBS	NONE
		THIRD ANGLE PROJECTION	
		SHT 3 OF 5	
		SIZE	
		A	

THIS COPY IS PROVIDED ON A RESTRICTED BASIS AND IS NOT TO BE USED IN ANY WAY DETRIMENTAL TO THE INTERESTS OF PANDUIT CORP.

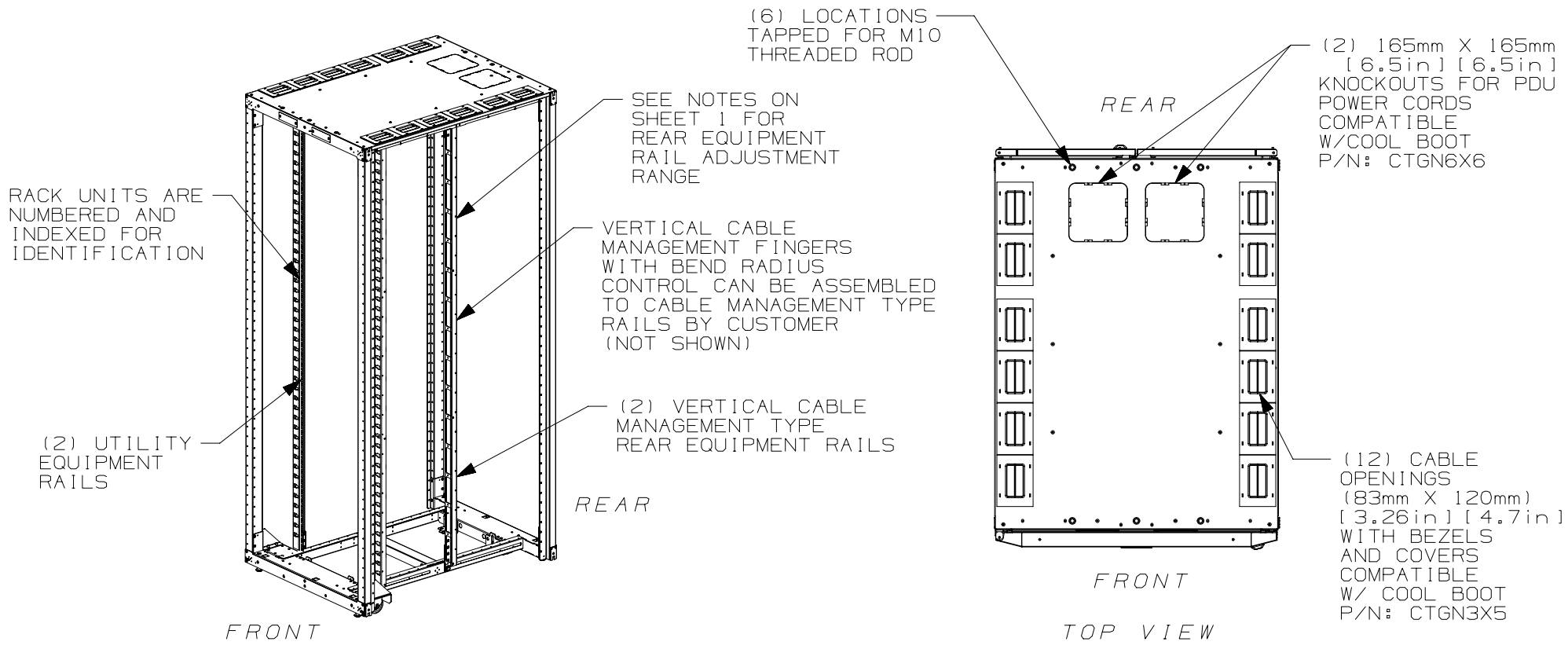

FRONT DOOR, REAR DOOR, AND SIDE PANELS NOT SHOWN

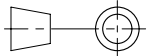
							TITLE		NET-ACCESS S TYPE UTILITY CABINET 800mm WIDE X 1070mm DEEP FAMILY					
							CUSTOMER DRAWING		PANDUIT					
							ITEM REVISION NAME					12V352BS/01.PRT		
							DATASET FILE NAME					12V352BS_DC/01A.PRT		
							MATERIAL:		N/A					
							DRAWING NUMBER:		12V352BS-DC					
01A	11-26-14	PBS	ADP	TCN	SEE SHEET 1 OF 5 FOR REVISIONS	V09000BX	 THIRD ANGLE PROJECTION		DRAWN BY: MDCA DATE: 6-06-13 CHK: PBS SCALE: NONE					
00A	6-06-13	MDCA	PBS	JDWE	SEE SHEET 1 OF 5 FOR REVISIONS	12V352BS-DC						SHT 4 OF 5		
REV	DATE	BY	CHK	APR	DESCRIPTION	ECN			SIZE A					

THIS COPY IS PROVIDED ON A RESTRICTED BASIS AND IS NOT TO BE USED IN ANY WAY DETRIMENTAL TO THE INTERESTS OF PANDUIT CORP.

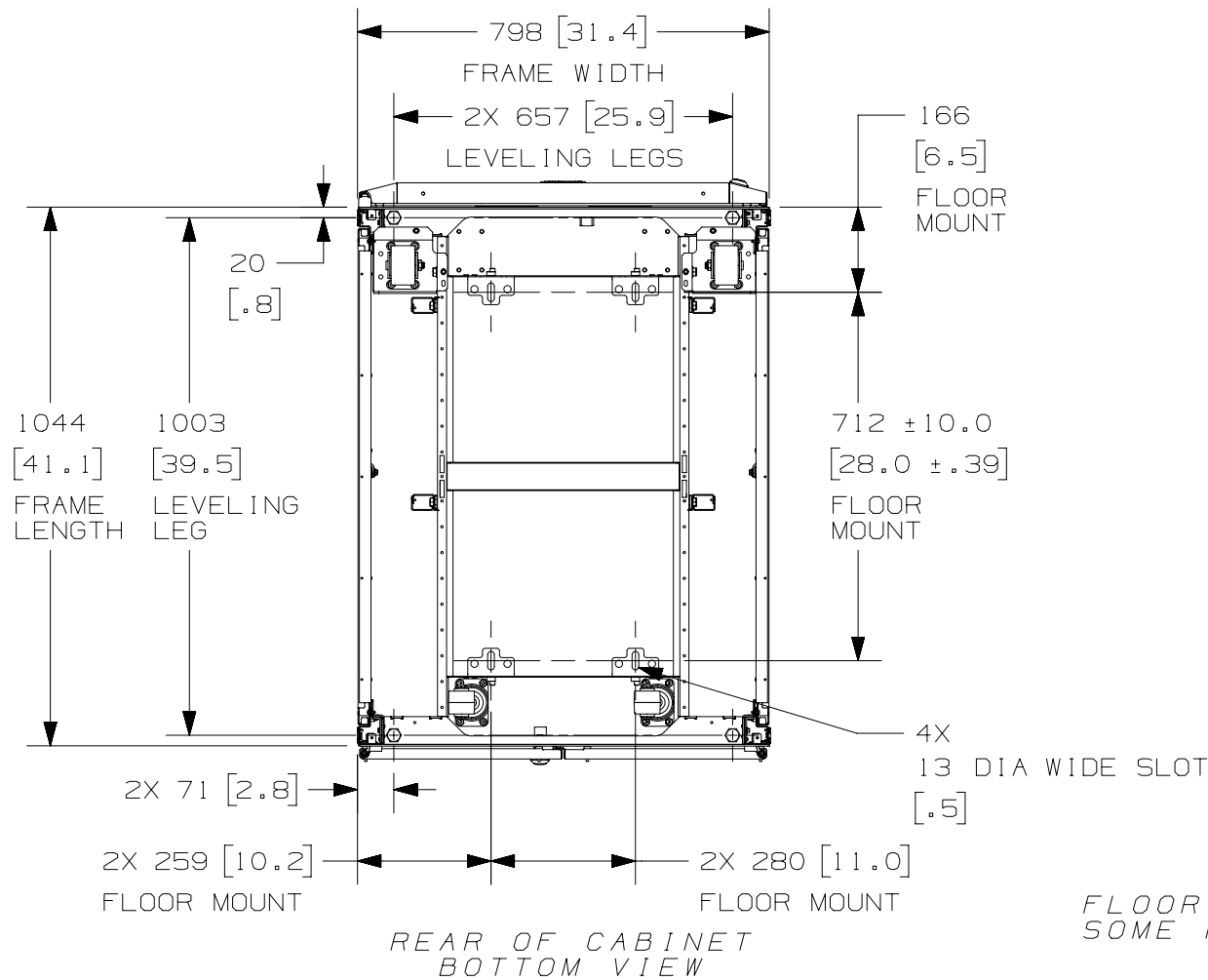

REV	DATE	BY	CHK	APR	DESCRIPTION	ECN
01A	11-26-14	PBS	ADP	TCN	SEE SHEET 1 OF 5 FOR REVISIONS	V09000BX
00A	6-06-13	MDCA	PBS	JDWE	SEE SHEET 1 OF 5 FOR REVISIONS	12V352BS-DC

TITLE		NET-ACCESS S TYPE UTILITY CABINET 800mm WIDE X 1070mm DEEP FAMILY	
		CUSTOMER DRAWING	
ITEM REVISION NAME		12V352BS/01.PRT	
DATASET FILE NAME		12V352BS_DC/01A.PRT	
		MATERIAL: N/A	
		DRAWING NUMBER: 12V352BS-DC	
DRAWN BY	DATE	CHK	SCALE
MDCA	6-06-13	PBS	NONE
THIRD ANGLE PROJECTION		SHT 5 OF 5	
SIZE		A	

2

1