

THIS COPY IS PROVIDED ON A RESTRICTED BASIS AND IS NOT TO BE USED IN ANY WAY DETRIMENTAL TO THE INTERESTS OF PANDUIT CORP.

2

1

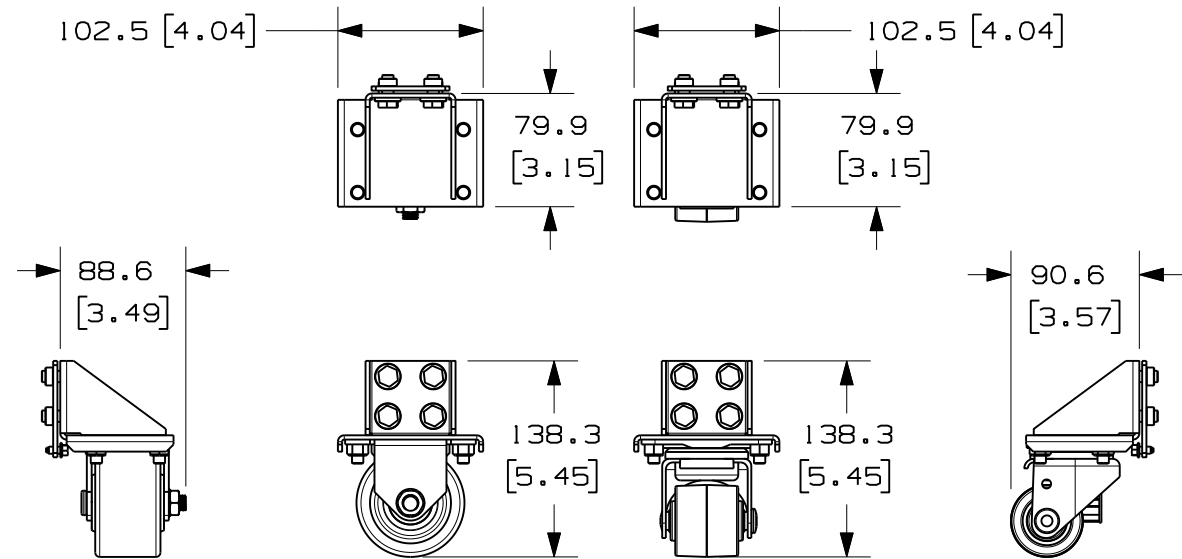

FIXED CASTER

SWIVEL CASTER

SWIVEL CASTER ASSEMBLY
2 PLCS AT
REAR OF CABINET

FIXED CASTER ASSEMBLY
2 PLCS AT
FRONT OF CABINET

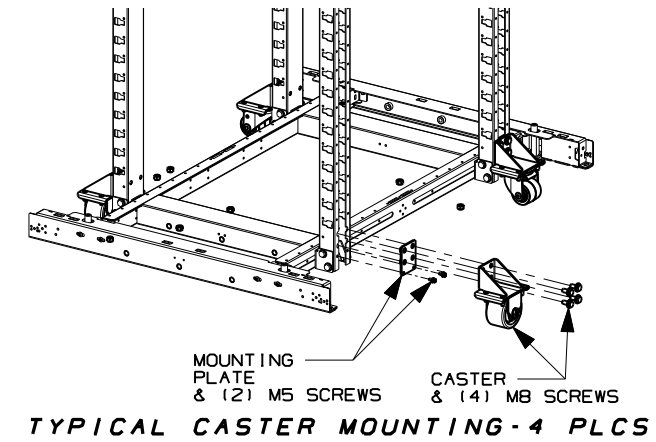
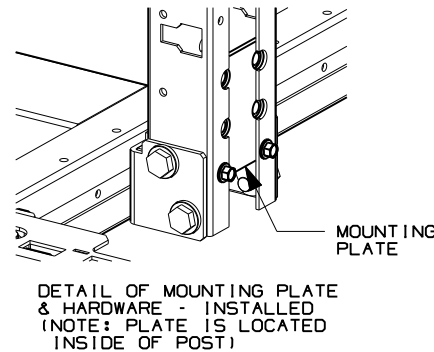
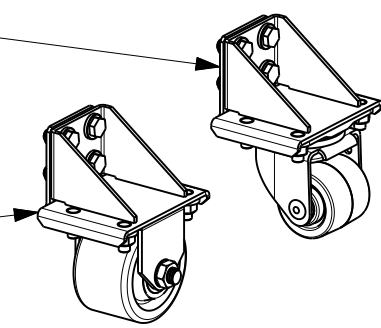

TYPICAL CASTER MOUNTING - 4 PLCS

PANDUIT P/N	WEIGHT
NCSTR4	5.5 Kg/EACH 12.1 LBS/EACH

NOTES:

- VISIT OUR ON-LINE CATALOG AT WWW.PANDUIT.COM FOR A LIST OF CURRENT PARTS APPLICABLE FOR USE WITH THIS PRODUCT.
- PRIMARY DIMENSIONS ARE IN MILLIMETERS (mm).
- PARTS SUPPLIED:
 (2) - FIXED CASTER ASSEMBLIES
 (2) - SWIVEL CASTER ASSEMBLIES
 (4) - MOUNTING PLATES
 (8) - M5 HEX HEAD SCREWS
 (16) - MB HEX HEAD SCREWS
 (1) - INSTRUCTION SHEET
- CASTERS ADD 24mm (1") TO HEIGHT OF CABINET.

REV	DATE	BY	CHK	APR	DESCRIPTION	ECN
OOA	9-21-12	LEE	ANI	JdWE	RELEASED TO PRODUCTION	12V305KY-DC

TITLE N-TYPE CABINET CASTER KIT (NCSTR4) CUSTOMER DRAWING	
CONTROL DRAWING	
ITEM REVISION NAME 12V305KY/00.PRT	PANDUIT TM
DATASET FILE NAME 12V305KY_DC/00A.PRT	
UNLESS OTHERWISE SPECIFIED, DIMENSIONAL TOLERANCES ARE:	
INCHES X.X +/- 0.03 X.XX +/- 0.018 X.XXX +/- 0.007	METRIC - MILLIMETER X +/- 0.8 X.X +/- 0.46 X.XX +/- 0.18
ANGLE +/- 1°	
DRAWING NUMBER: 12V305KY-DC	
THIRD ANGLE PROJECTION	
DRAWN BY LEE	DATE 9-20-12
CHK	SCALE NONE
SHT 1 OF 1	
SIZE A	

2

1