

THIS COPY IS PROVIDED ON A RESTRICTED BASIS AND IS NOT TO BE USED IN ANY WAY DETRIMENTAL TO THE INTERESTS OF PANDUIT CORP.

PANDUIT P/N	WEIGHT
CHS2R2**-X	.16 LB/10 PCS. (74 G/10 PCS)

NOTES:

1. SEE CURRENT CATALOG FOR ADDITIONAL PART NUMBER SUFFIXES TO INDICATE COLOR AND OR PACKAGE QUANTITY.
2. SEE CATALOG FOR COMPLETE LIST OF PARTS APPLICABLE FOR USE WITH THIS PART.
3. DIMENSIONS IN [] ARE IN METRIC.

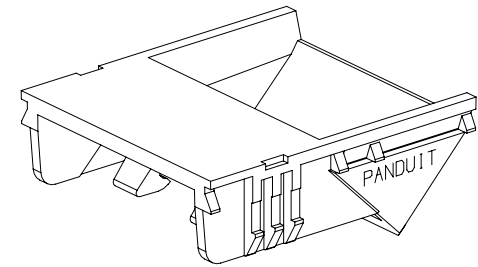
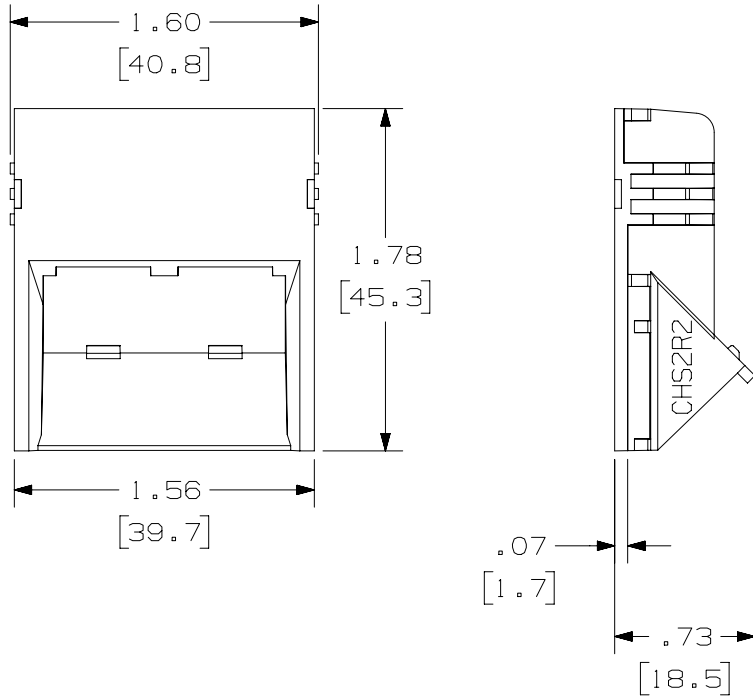

PART NUMBER		CHS2R2** - X	
TITLE			
MINI-COM 2 POSITION SLOPED RECESSED 2/3 SIZE INSERT			
CUSTOMER DRAWING			
ITEM REVISION NAME		D35544CA/00	
DATASET FILE NAME		D35544CA_DC_02B	
UNLESS OTHERWISE SPECIFIED, DIMENSIONAL TOLERANCES ARE: IN [mm]		MATERIAL:	
.X ± .xxx ± .010 [.3]		ABS	
.XX ± .03 [.8]		DRAWING NUMBER:	
ANGLES ±		35544 - 25	
THIRD ANGLE PROJECTION		SHT 1 OF 1	
DRAWN BY	DATE	CHK	SCALE
JBA	12-23-96	CEF	NONE
REV	DATE	BY	CHK
3	4/23/14	JSP	REFR
MMR	REVISED AND REDRAWN, PREVIOUS REVISIONS HAVE BEEN OMITTED.		35544-25
APR	DESCRIPTION		ECN

D10100DA/14

2

1

2

1