

Net-Access™ S-Type Cabinets – 45 RU

specifications

The Net-Access™ S-Type Cabinets shall consist of a welded and assembled steel frame construction available in 600mm (23.6"), 700mm (27.6"), and 800mm (31.5") widths, 1068mm (42.0"), and 1220mm (48.0") depths, and 42 RU, 45 RU, and 48 RU heights. The top of cabinet includes molded edge protection and snap-in covers, and pre-installed in cable entry openings to prevent air leakage. Cabinets shall include front single hinge doors with 69% open perforation and rear perforated or solid split doors. Cabinets shall have rails with provisions for rear cable management fingers (some finger sold separately) or to accept Zero RU QuickNet™ Style Inserts. Cabinet shall have one set of PDU brackets. The entire cabinet shall be fully electrically bonded, including equipment rails, door, and side panels. Single point bonding locations shall be available at the top and bottom of each cabinet. Cabinets shall have a 1360kg (3000 lbs.) load rating and 1136kg (2500 lbs.) rolling load rating.

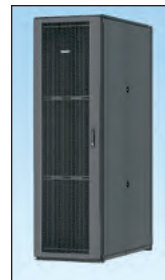

technical information

| | |
|------------------------------------|--|
| Dimensions: | 45 RU – 600mm W (23.6") x 1068mm D (42.0") x 2160mm H (85.0") 45 RU – 600mm W (23.6") x 1220mm D (48.0") x 2160mm H (85.0") 45 RU – 700mm W (27.6") x 1068mm D (42.0") x 2160mm H (85.0") 45 RU – 700mm W (27.6") x 1220mm D (48.0") x 2160mm H (85.0") 45 RU – 800mm W (31.5") x 1068mm D (42.0") x 2160mm H (85.0") 45 RU – 800mm W (31.5") x 1220mm D (48.0") x 2160mm H (85.0") |
| Rail span by cabinet depth: | 600mm Wide 1067mm Deep – 2.5" (65mm) to 14.1" (357mm) and 20.5" (521mm) to 30.1" (765mm) (35.9" (911mm) without PDUs) 1219mm Deep – 2.5" (65mm) to 17.1" (435mm) and 23.0" (538mm) to 36.2" (919mm) (42.0" (1065mm) without PDUs) 700mm Wide 1067mm Deep – 5.6" (141mm) to 17.2" (437mm) and 20.7" (526mm) to 36.8" (933mm) 1219mm Deep – 5.6" (141mm) to 21.0" (532mm) and 23.0" (538mm) to 42.7" (1085mm) 800mm Wide 1067mm Deep – 5.6" (141mm) to 17.2" (437mm) and 20.7" (526mm) to 36.8" (933mm) 1219mm Deep – 5.6" (141mm) to 21.0" (532mm) and 23.0" (538mm) to 42.7" (1085mm) |
| Material: | Steel with durable black polyester epoxy powder coat finish |
| Compliance: | EIA-310-E TIA/EIA-942 UL2416 |
| Packaging: | Cabinet ships assembled, one per pallet |

key features and benefits

| | |
|---|--|
| Versatility | Wide range of cabinet designs available for specific thermal applications, resulting in improved thermal efficiencies and reductions in energy expenditures |
| Thermal efficiency | Integral blanking panels and cabinet sealing features reduce bypass air and mixing of cold air and exhaust air within the cabinet for improved thermal efficiency |
| Total air sealing | Panduit cabinets, thermal ducting, cool boot product, blanking panels, blanking foam strips, and blanking shade provide a complete thermal and sealing solution (parts sold separately) |
| Aesthetics | N-Type and S-Type cabinets can be ganged together for complete streamlined appearance improving data center aesthetics |
| Rapid deployment | Integrated casters to provide easy roll to position; cable management ready rails included help speed deployment; easily adjustable rear rails can be quickly repositioned; heavy duty leveling legs can be accessed from top or bottom for faster deployment |
| Bonding | Cabinets and accessories are single-point bonded, providing a safe and reliable network while reducing installation costs |
| Modular cable management fingers | Provides bend radius control for each rack unit and can be positioned where required on cabinet posts for cable protection for increased network availability; provides design flexibility, scalability, and improved aesthetics for easier moves, adds, and changes |
| Expansive offering | Multiple cabinet configurations for hot aisle/cold aisle, cold aisle containment, or vertical exhaust ducting deployments |
| Durable coating | Cabinets are powder coated in a durable, low maintenance polyester epoxy paint available in black (RAL9005), or white (RAL9003) |

applications

Net-Access™ S-Type Cabinets provide unparalleled value incorporating integral thermal sealing and cable management options that provide cost effective solutions to meet the diverse application needs of today's data centers. Complete range of sizes and seamless integration with Net-Contain™ VED and

Cold Aisle Containment Systems optimize thermal efficiency across virtually any data center application. Zero RU E-rail and outset cable entry enables vertical patching for 600mm (24") wide cabinets gaining up to 4 RU's per cabinet, optimizing cabinet and data center utilization.

Net-Access™ S-Type Cabinets

Refer to the next page for the Net-Access™ S-Type Standard Configured Cabinets part number configurator.

Vertical Exhaust Ducting Applications 800mm x 42 RU x 1200

| | |
|------------------------------------|----------------|
| 406mm to 660mm (16" to 26" tall): | C2VED0811626*1 |
| 660mm to 965mm (26" to 38" tall): | C2VED0812638*1 |
| 965mm to 1676mm (38" to 66" tall): | C2VED0813866*1 |

Accessories

| | |
|--|-----------|
| D-Ring kit for full length POU bracket 25mm (1 inch) deep: | S1DR |
| D-Ring kit for full length POU bracket 60mm (2.4 inch) deep: | S2DR |
| L-Ring kit for full length POU bracket 40mm (1.6 inch) deep: | S1LR |
| L-Ring kit for full length POU bracket 70mm (2.8 inch) deep: | S2LR |
| 45 RU 1070mm standard side panel – black: | S51SPSE |
| 45 RU 1070mm standard side panel – white: | S51SPSEW |
| 45 RU 1200mm standard side panel – black: | S52SPSE |
| 45 RU 1200mm standard side panel – white: | S52SPSEW |
| Casters: | SCSTR4 |
| 45 RU Finger Kit – 100mm (4") long: | SN15F |
| 45 RU Finger Kit – 150mm (6") long: | SN25F |
| Three digit combination lock with key: | CCL3 |
| Vertical patching bracket for 700mm wide cabinets: | S7VPPB |
| Vertical patching bracket for 800mm wide cabinets: | SN8VPPB |
| Cool Boot® Cabinet Top Air Sealing Fitting for 6.5 x 6.5 cabinet top opening: | CTGN6X6 |
| Cool Boot® Cabinet Top Air Sealing Fitting for 3.5 x 5 cabinet top opening: | CTGN3X5 |
| Cool Boot® Cabinet Top Air Sealing Fitting for 1 x 5 cabinet top opening: | CTGN1X5 |
| Cabinet top cable protection bezel for 6.5 x 6.5 cabinet top opening: | CTNBZL6X6 |
| Cabinet top cover and cable protection bezel for 3.5 x 5 cabinet top opening: | CTCN3X5 |
| Cabinet top cover and cable protection bezel for 1 x 5 cabinet top opening: | CTCN1X5 |

*Part number shown as Black. Add Suffix W for White.

Net-Access™ S-Type Cabinets – 45 RU

Net-Access™ S-Type standard configured cabinets

| Series | Width | Height | Depth | Side Panels | Color | Standard Options (Select Only One) |
|--------|-------------------------------------|-------------------------------------|--------------------------|---|------------------------|---|
| S | 6 = 600mm 7 = 700mm 8 = 800mm | 2 = 42 RU 5 = 45 RU 8 = 48 RU | 1 = 1070mm 2 = 1200mm | 2 = 2 Side Panels* 9 = No Side Panel | B = Black W = White | A = Switch Configured with Front Cable Management (PDU bracket not included) A9 = Switch Configured with Front Cable Management and No Casters F = Vertical Cable Management Fingers P = Vertical Patching Equipment Rails S = No Doors T = Integral Cabinet Top Cable Routing System T9 = Integral Cabinet Top Cable Routing System and No Casters V = VED Ready V9 = VED Ready and No Casters 9 = No Casters |

*Standard side panel. P – only available for 600mm wide S-Type Cabinets. V and V9 – only available for 1200mm deep cabinets.

Standard Configurations have 6 characters with only one standard option suffix.

| | | | | | | |
|---|---|---|---|---|---|--|
| S | 6 | 2 | 1 | 2 | B | |
|---|---|---|---|---|---|--|

45 RU cabinet dimensions

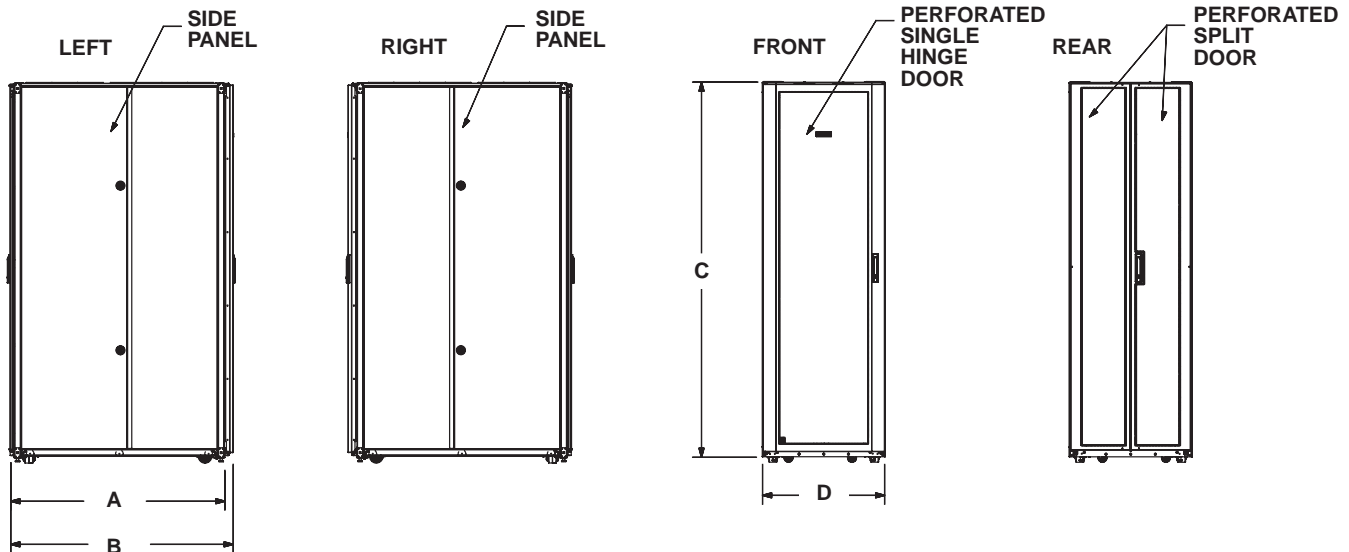

| Nominal Cabinet Depth | Dimension A | Dimension B | Dimension C | Dimension D |
|-----------------------|----------------|----------------|----------------|---|
| 1070mm | 1068mm (42.0") | 1115mm (43.9") | 2159mm (85.0") | 598mm (23.5") 698mm (27.5") 798mm (31.4") |
| 1200mm | 1219mm (48.0") | 1269mm (50.0") | 2159mm (85.0") | 598mm (23.5") 698mm (27.5") 798mm (31.4") |

WORLDWIDE SUBSIDIARIES AND SALES OFFICES

PANDUIT CANADA
Markham, Ontario
cs-cdn@panduit.com
Phone: 800.777.3300

PANDUIT EUROPE LTD.
London, UK
cs-emea@panduit.com
Phone: 44.20.8601.7200

PANDUIT SINGAPORE PTE. LTD.
Republic of Singapore
cs-ap@panduit.com
Phone: 65.6305.7575

PANDUIT JAPAN
Tokyo, Japan
cs-japan@panduit.com
Phone: 81.3.6863.6000

PANDUIT LATIN AMERICA
Guadalajara, Mexico
cs-la@panduit.com
Phone: 52.33.3777.6000

PANDUIT AUSTRALIA PTY. LTD.
Victoria, Australia
cs-aus@panduit.com
Phone: 61.3.9794.9020

For a copy of Panduit product warranties, log on to www.panduit.com/warranty

For more information

Visit us at www.panduit.com

Contact Customer Service by email: cs@panduit.com
or by phone: 800.777.3300

PANDUIT®

©2015 Panduit Corp.
ALL RIGHTS RESERVED.
RKSP90--WW-ENG
2/2015