

QuickPort® Duplex Type-106 Inserts

APPLICATION

QuickPort Duplex Type-106 Inserts accept all individual QuickPort snap-in modules (sold separately). Use to support multimedia applications where a flush-mount electrical-wallplate look is desired, or where there will be multiple devices—or a combination of electrical and voice/data devices—under a multi-gang wallplate. Available in ivory, light almond, white, grey, and black.



4-Port Insert

2-Port Insert

SPECIFICATION

The workstation connector housing shall be a field-configurable NEMA-style housing that mounts flush in standard NEMA openings, and under standard duplex electrical wallplates in single or multiple gangs. It shall provide ports which are field configurable with a variety of simplex snap-in connector modules. The insert shall be constructed of high-impact, fire-retardant plastic rated UL 94V-0, and be UL Listed, and compliant with ANSI/TIA-568-C.0 specifications. Colors, configurations, and related wallplates to be specified per schedule on plan. The manufacturer shall provide a one-year limited product warranty and 15-year product performance guarantee. The manufacturer shall provide a lifetime warranty against defects in material and workmanship, and an application guarantee when installed as part of a certified system.

FEATURES

- Fits within minimum NEMA openings
- Compatible with all individual QuickPort modules
- Brass-threaded insert for wallplate screw facilitates installation
- Narrow module width allows high port density in a small area
- The Quad 106 features a built-in termination station which stabilizes connectors during punchdown
- Fits Decora® and duplex wallplates

DESIGN CONSIDERATIONS

- Use where a flush-mount electrical-style wallplate look is desired
- Fits most locations where NEMA duplex opening exists (including floor monuments, access floor boxes, power poles, poke-through fixtures, etc.)
- If ganged with electrical devices, a barrier box must be used
- Put blanks (41084-BxB) in unused ports for future expansion
- Specify port identification method (colored modules, designation labels, and custom silk-screening are available). To ID ports, use different colored connectors for each application, or Leviton pre-printed Port Designation Labels (41080-LEB)

STANDARDS COMPLIANCE

- 4-Port Insert: UL Listed, CSA certified, and ANSI/TIA-568-C.0
 2-Port Insert: cULus listed and ANSI/TIA-568-C.0

PHYSICAL SPECIFICATIONS

- Dimensions: See page two
 Materials: High-impact, fire-retardant plastic rated UL 94V-0
 Capacity: Two or four ports

COUNTRY OF ORIGIN

- 4-Port Insert: Mexico
 2-Port Insert: USA

WARRANTY INFORMATION

For a copy of Leviton product warranties, visit www.leviton.com/warranty.

ELECTRONIC FILES

For CAD files, typical specs, or technical drawings (.DXF, .DWG), visit www.leviton.com.

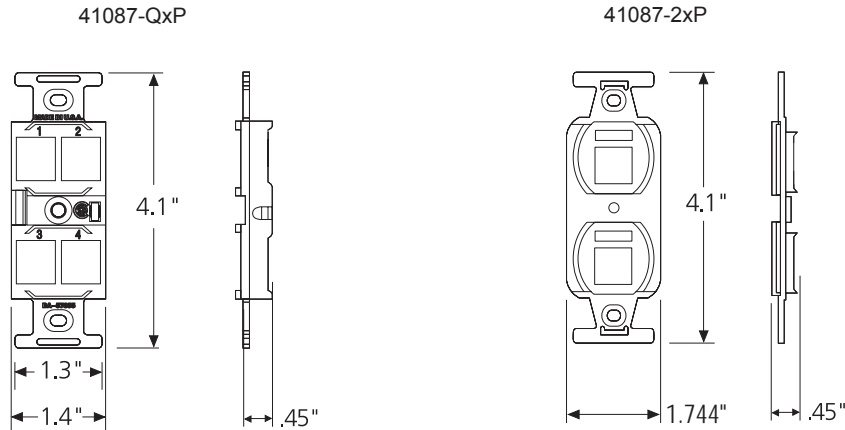

41087-xxP

PART NUMBERS

Description	IVORY	LT. ALMOND	WHITE	GREY	BLACK
QuickPort® Duplex Type-106 Insert, 2 Ports	41087-2IP	41087-2TP	41087-2WP	41087-2GP	41087-2EP
QuickPort Duplex Type-106 Insert, 4 Ports	41087-QIP	41087-QTP	41087-QWP	41087-QGP	41087-QEP

Note: QuickPort snap-in connector modules and duplex electrical wallplates are sold separately. Please refer to the QuickPort connector spec sheets and the Leviton catalog for ordering information.



Leviton Network Solutions
2222 - 222nd St. SE
Bothell, WA 98021-4416

Asia / Pacific
T +1.631.812.6228
E infoasean@leviton.com

Canada
T +1.514.954.1840
E pcservice@leviton.com

Caribbean
T +1.954.593.1896
E infocaribbean@leviton.com

China
T +852.2774.9876
E infochina@leviton.com

Colombia
T +57.1.743.6045
E infocolombia@leviton.com

tel 1-800-824-3005
tel +1-425-486-2222
appeng@leviton.com
www.leviton.com

Europe
T +33.6.8869.1380
E infoeurope@leviton.com

India / SAARC
T +971.4.886.4722
E infoindia@leviton.com

Mexico
T +52.55.5082.1040
E lsamarketing@leviton.com

Middle East & Africa
T +971.4.886.4722
E lmeinfo@leviton.com

South Korea
T +82.2.3273.9963
E infokorea@leviton.com