

# DRK Series

## 19" PANEL WIDTH CABLE MANAGEMENT ENCLOSURE

extra wide multi-bay design  
contains integral cable ducts  
ideal for accommodating  
large cable bundles

### FEATURES:

- Fully welded construction provides the following weight capacities
  - UL Listed load capacity: 2,500 lbs
  - Seismic load capacity: 755 lbs.
- 30" OD width, 31-1/2", 36" and 42" OD depths available
- Includes 100 qty. rack screws
- 4 Grounding and bonding studs installed in base and top
- 1/2", 3/4", 1" & 1-1/2" electrical knockouts on split rear plates (top & bottom), easily removable for cable pass-through, top plates additionally include UHF/ VHF knockouts
- 2 pairs of wide 11-gauge rackrail labeled with EIA standard rackspace increments available 10-32 threaded or cage-nut style
- Vented rear door standard
- One pair of cable ducts with solid steel hinged doors and 4-point magnetic closure pre-installed in front
- Seismic Certified (when used with MRK-Z4 option) with an Ip value of 1.5
- Durable black textured powder coat finish
- UL Listed in the US and Canada



DRK19-44-31

### SPECIFICATIONS:

EIA compliant 19" panel width equipment enclosure shall be Middle Atlantic Products model # DRK19-44-\_\_ (31, 31PRO, 31K, 36, 36PRO, 42). Overall dimensions of enclosure shall be 83-1/2"H x 30"W x \_\_ (31-1/2", 36", 42")D. Useable height shall be 44 rackspace, useable depth shall be \_\_ (24-1/4", 28-3/4", 34-3/4"). Fully welded construction shall provide a UL Listed 2,500 lb. weight capacity. Enclosure shall be constructed of the following materials: top, bottom and horizontal braces shall be steel, all structural elements shall be finished in durable black powder coat. Rack shall include a vented, locking and latching rear door. Enclosure shall come equipped with 10" fan top and fan guard for ventilation, one pair of cable ducts with steel doors pre-installed in front of rack, two pairs of rackrail with \_\_ (tapped 10-32, 6mm cage nut) mounting holes in universal EIA spacing, finished in black e-coat with numbered rackspace, and vented rear door. Rack shall have a removable rear knockout panel with 1/2", 3/4", 1", and 1-1/2" electrical knockouts installed in base, and removable split rear knockout panels with electrical knockouts and BNC knockouts for UHF/ VHF antennae installed in top. Grounding and bonding studs shall be zinc plated 1/4-20x1 threaded, installed two each in base and top of enclosure (DRK19-44-31K shall additionally include plexiglass front door, one pair lockable side panels, and leveling feet). DRK Series enclosures shall satisfy the 2007 & 2010 CBC; 2006, 2009 & 2012 IBC; ASCE 7-05 (2005 Edition) & ASCE 7-10 (2010 Edition) and the 2006 & 2009 editions of NFPA 5000 for use in areas of high seismicity, Seismic Use Group III, Zone 4 or Seismic Design Category (SDC) "D" with lateral force requirements for protecting 755 lbs. of essential equipment in locations with the highest level of seismicity and top floor or rooftop installations with an Importance factor (Ip) of 1.5 when used with MRK-Z4 seismic floor anchor bracket. Rack shall be OSHPD approved for fixed equipment anchorage in California healthcare facilities. DRK shall be UL Listed in the US and Canada. DRK shall be GREENGUARD Gold Certified. DRK enclosure shall be RoHS EU Directive 2011 / 65 / EU compliant. DRK shall be manufactured by an ISO 9001 and ISO 14001 registered company. Rack enclosure shall be warranted to be free from defects in material or workmanship under normal use and conditions for the lifetime of the rack.

Customizable specification clips available at [middleatlantic.com](http://middleatlantic.com)



PRODUCT CERTIFIED FOR  
LOW CHEMICAL EMISSIONS  
UL.COM/GG  
UL 2818

### OPTIONS:

- Front doors shall be model # DPVFD-44 (vented plexi), model # DPFVFD-44 (plexi), model # DVFD-44 (25% open area), model # DLVFD-44 (70% open area)
- Split rear door, vented with 76% open area shall be model # DCLVRD-44
- Additional rail kit, 11-gauge, 10-32 threaded, with EIA numbered spacing shall be model # DRK19-RR44
- Additional rail kit, 11-gauge, cage-nut style, with EIA numbered spacing shall be model # DRK19-RR44PRO
- Caster base shall be model # CBS-DRK-31 (31-1/2" overall depth), CBS-DRK-36 (36" overall depth)
- Pair of keylocked side panels shall be model # SPN-44-312 (31-1/2" overall depth), SPN-44-36 (36" overall depth), SPN-44-423 (42" overall depth)
- Optional 10" ventilation fan shall be model # FAN-10
- Top panels shall be 16-gauge steel, multiple styles available including model # MW-ST (solid), MW-4FT (four 4-1/2" fans), MW-6FT (three 6" fans), MW-VT (vented) and MW-LA (accepts 6" and 12" cable ladders)
- Additional cable duct shall be model # DRK-44DUCT, sold individually
- Rail bracket adapters shall allow for mounting of blank or other panels vertically between rackrail brackets. Available for 44 space enclosures and be model # RBA-MV44-2 (2 rackspace)
- Seismic compliance floor anchor brackets shall be model # MRK-Z4

WHAT GREAT SYSTEMS ARE BUILT ON.™

A brand of Legrand

Middle Atlantic Products  
[middleatlantic.com](http://middleatlantic.com) | [middleatlantic.ca](http://middleatlantic.ca)

96-967/ rev i / 12-1-17

# DRK Series

## BASIC DIMENSIONS

NOTE:  
ALL DIMENSIONS IN FORMAT:  
INCHES [MILLIMETERS]

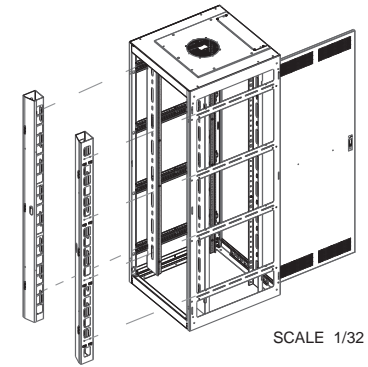
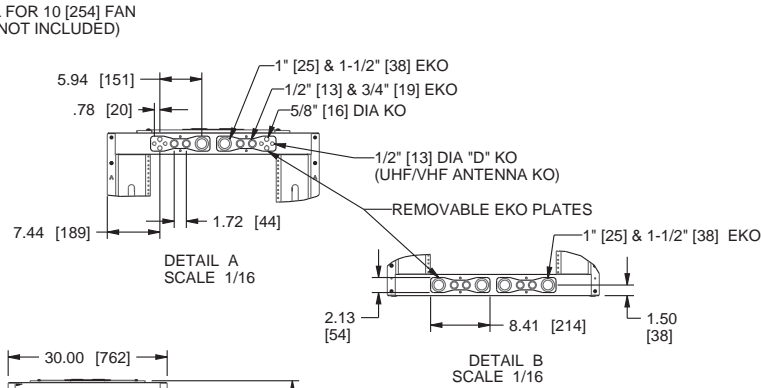
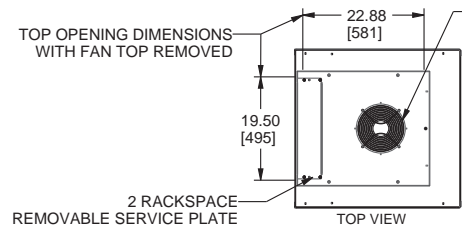

SCALE 1/32

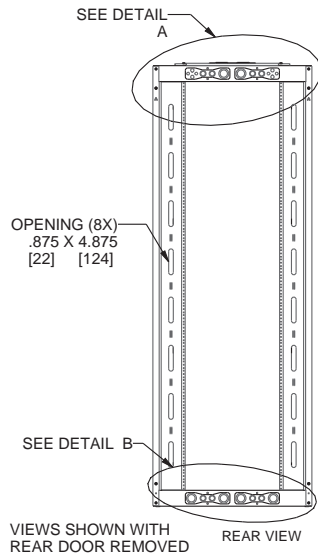

VIEWS SHOWN WITH REAR DOOR REMOVED

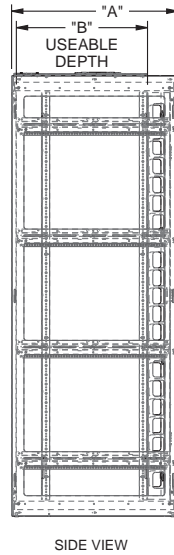

SIDE VIEW

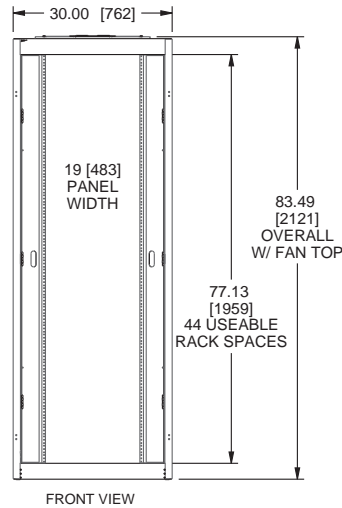

FRONT VIEW

**DIMENSIONAL NOTES:**  
 - SPN-44-XXX ADDS .625 [16] PER SIDE TO OVERALL WIDTH.  
 - CBS-DRK-XX ADDS .75 [19] TO OVERALL HEIGHT.  
 - DXFD-44 ADDS .92 [23] TO OVERALL DEPTH.  
 - REMOVAL OF FAN TOP REDUCES HEIGHT BY .375 [10].

MODEL #.	REAR DOOR	RAIL TYPE	A	B	C	D	E
DRK19-44-31	YES	10-32 THREADED	31.40 [798]	24.25 [616]	27.26 [692]	29.29 [744]	26.51 [673]
DRK19-44-31LRD	NO	10-32 THREADED					
DRK19-44-31PRO	YES	CAGE NUT					
DRK19-44-31PROLRD	NO	CAGE NUT					
DRK19-44-31K*	YES	10-32 THREADED	36.00 [914]	28.85 [733]	31.86 [809]	33.89 [861]	31.11 [790]
DRK19-44-36	YES	10-32 THREADED					
DRK19-44-36LRD	NO	10-32 THREADED					
DRK19-44-36PRO	YES	CAGE NUT					
DRK19-44-36PROLRD	NO	CAGE NUT	42.00 [1067]	34.85 [885]	37.86 [962]	39.89 [1013]	37.11 [943]
DRK19-44-42	YES	10-32 THREADED					
DRK19-44-42LRD	NO	10-32 THREADED					
DRK19-44-42PRO	YES	CAGE NUT					
DRK19-44-42PROLRD	NO	CAGE NUT					

\*INCLUDES PLEXI FRONT DOOR, LEVELING FEET, REMOVABLE SIDE PANELS

WHAT GREAT SYSTEMS ARE BUILT ON.™

A brand of Legrand

**Middle Atlantic Products**  
 middleatlantic.com | middleatlantic.ca

# DRK Series

## BASIC DIMENSIONS

NOTE:  
ALL DIMENSIONS IN FORMAT:  
INCHES [MILLIMETERS]

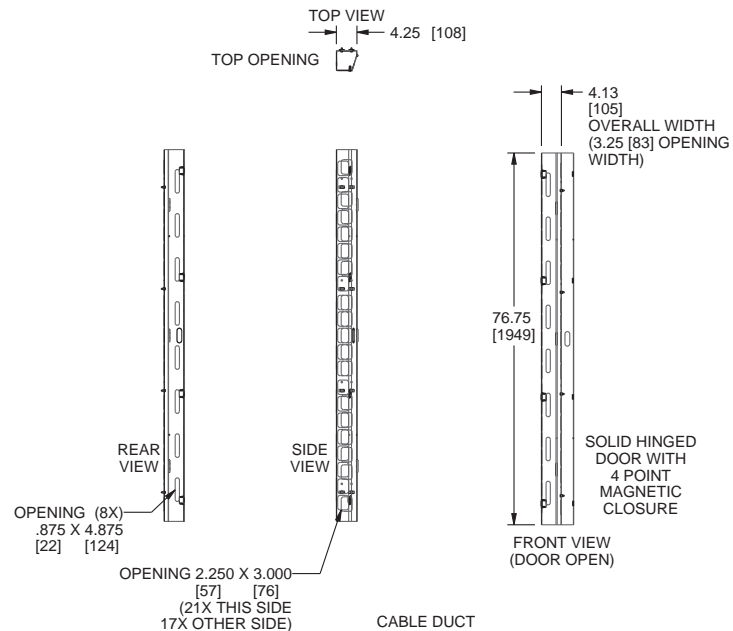
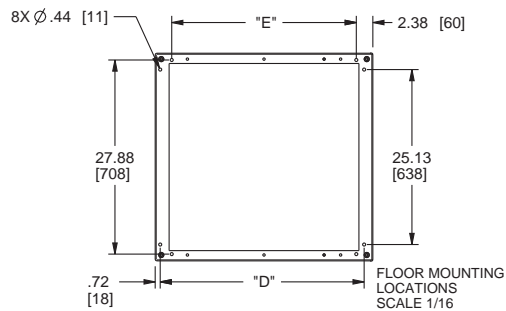
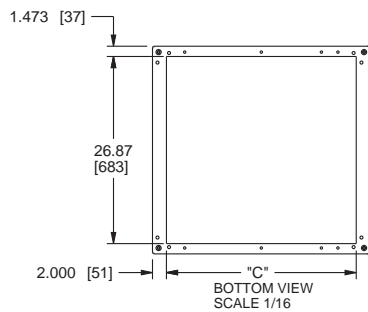

WHAT GREAT SYSTEMS ARE BUILT ON.™

A brand of legrand

Middle Atlantic Products  
middleatlantic.com | middleatlantic.ca