

Cylinder Parts: Bored, Auxiliary and Integra Locks

Cylinders and Components

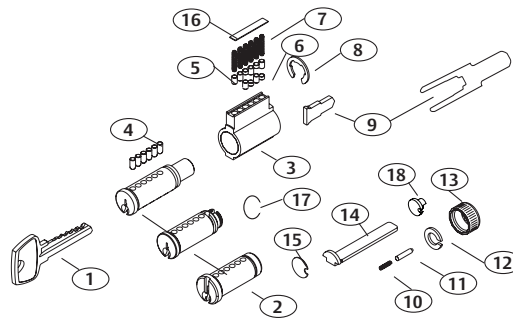

Hotel Function Not Shown



Item	Description	Lock Line	Part Number	Comment
1	6 Pin Key Blank		See Table Page 16	
2	Plug Plug Plug Plug Plug & Pin Assembly Plug & Ring Assembly	7600 470, 480, 1655, 7500 460 5500*, 8X 7, 8, 9* Knobs 6, 7 Lever, 8L*, 10, 11, 6500, 7500, 758, 858	13-0090 13-0874 13-0904 13-0920 13-3425 13-3142	New 7600 Only
3	Shell Only Cylinder Shell & Slide Assembly Without Pins & Springs	7600 7, 8L*, 10, 11 Levers, 758, 858 7, 8*, 9* Knobs 6, 6500 460, 470, 480, 1655 5500*, 8X	13-1139 13-3257 13-2048 13-3257 - Effective 9/03 13-3493 13-3514	7600 (No Slide) Illustration Shows Slide Disassembled
4	Bottom Pin	All Cylinders	See Table Page 14	
5	Top Pin	All Cylinders	13-0059	Pin No. 10 (Length .200)
6	Master Pin	All Cylinders	See Table Page 14	
7	Compression Spring	All Cylinders	13-0265	
8	Plug Retainer Plug Retainer Ring	5* 7, 8*, 9 Knob manufactured prior to March 2005	01-0870 06-0166	
	Plug Retainer Ring	6, 7 Lever, 8L*, 10, 11, 6500 and 8 line* knob manufactured after April 2005	13-0205	
	Plug Retainer Ring	5500, 8X	01-0870	
9	60-70 Tail Piece 70 Tail Piece 60 Tail Piece 70 Tail Piece 70 Tail Piece 70 Tail Piece 70 Tail Piece 60 Tail Piece Tail Piece Tail Piece Tail Piece Tail Piece Tail Piece Tail Piece Tail Piece	60-70 6500 70-6500 60-7, 10 70-7, 10 70-7, 10 70-7, 10 70-7, 10 60-11 11 7, 8L*, 10, 6500 6 (S & N Knobs) 6 (B Knob) 5500 758, 858 8X	05-0033 05-0034 10-0239 10-0239 10-0240 10-0286 10-0287 11-0171 13-1385 13-0895 13-0907 13-0908 13-0919 13-1230 13-1849	6 Pin Only 7 Pin Only Except 54 Function 6 Pin Except 54 Function 7 Pin Except 54 Function 6 Pin 54 Function 7 Pin 54 Function All Functions Except 50 Function 05, 24, 37, 38-2, 44
10	Cylinder Cap Spring	460, 470, 480, 1655	13-1555 - Effective 6/03 13-0693 - Prior to 6/03	
11	Cylinder Cap Pin	460, 470, 480, 1655	13-1554 - Effective 6/03 13-0691 - Prior to 6/03	
12	Cylinder Tail Washer	464, 474, 484 464, 465, 485, 486, 487, 1655	13-0882 13-0883	
13	Cylinder Endcap	460, 470, 485, 1655 series	13-0875 13-0903	
14	Tail Piece	464, 474, 484 465, 485, 487 475, 486	13-0878 13-0880 13-0881	1-3/4" to 2" (44mm to 51mm) Door Thickness
15	Blocking Piece	460, 470, 480, 1655	13-0884	
16	Slide (Mfg prior June 2008)	7 Old*, 7, 8*, 8L*, 9, 10, 11, 6500 7600	13-0779 13-0816	
16	Slide (Mfg after June 2008)	7, 8*, 8X, 9*, 10, 11, 1655, 6500	13-1341**	
17	Tail Piece Retainer	6, 7, 10, 11, 6500	13-0680	
18	Cam Connector	1655	13-1813	

* Discontinued Product
** See page 11 for Details

Key Blanks/Key Sections, Bitting Lists Cylinders and Components

5 Pin		6 Pin		7 Pin	
Key Blank	Key Section	Key Blank	Key Section	Key Blank	Key Section
265	U R	6265	U R S		LD LH LM LDH LDM LHM LN RD RH RM RDH RDM RHM RN
270	LD LH LM LDH LDM LHM LN RD RH RM RDH RDM RHM RN	6270	HD HH HM HHM HDH HDM HN RD RH RM RDH RDM RHM RN	7270	LD LH LM LDH LDM LHM LN RD RH RM RDH RDM RHM RN
273	CD CH CM CDH CHM CN	6273	CD CH CM CDH CHM CN	7273	CD CH CM CDH CHM CN
275	S				
275	LA LB LC LE LF LG LJ LK LL RA RB RC RE RF RG RJ RK RL	6275	HA HB HC HE HF HG HJ HK HL RA RB RC RE RF RG RJ RK RL	7275	LA LB LC LE LF LG LJ LK LL RA RB RC RE RF RG RJ RK RL
278	CA CB CC CE CF CG CJ CK CL CR	6278	CA CB CC CE CF CG CJ CK CL CR	7278	CA CB CC CE CF CG CJ CK CL CR

For Multiplex Masterkey Systems (L keyway family shown, others similar)

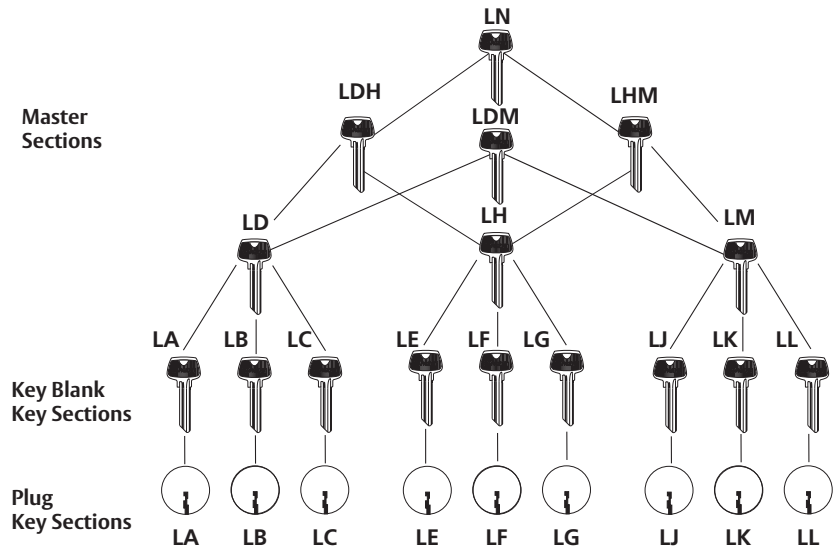

Multi Keyway Systems

- L – System Stock Keyways
- C – System Hotel Keyway (Furnished in Large Bow only)
- H – System Contract Master Key Systems
- R – System Contract MasterKey Systems

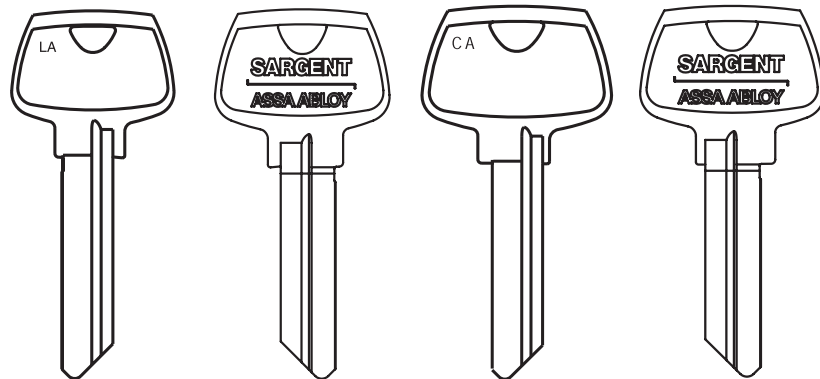

Standard 6 pin

Large Bow approximately 15% larger than standard bow. Provided for SARGENT "C" family as standard.

Single Keyway Sections

- R Section *
- S Section
- U Section *
- CR Section

* Cylinders ordered in either U or R single section only. Offered as 1 bitted for field keying

Restricted Keyways: Restricted keyways are SARGENT (factory) controlled geographically to limit sales and prevent unauthorized key duplication.

For availability of restricted keyways and key sections, contact SARGENT Key Records Department.

Orders for restricted keyway systems, key blanks and cylinders, require a letter of authorization from the system owner.

Copyright © 2006, 2008-2017, Sargent Manufacturing Company, an ASSA ABLOY Group company. All rights reserved. Reproduction in whole or in part without the express written permission of Sargent Manufacturing Company is prohibited.

90622:1 04/01/17