

Multi-Technology Ceiling Occupancy Sensor



GENERAL OPERATION

Occupancy sensors have two tasks: 1) Keeping the lights ON while the room is occupied, and 2) Saving energy by keeping the lights OFF while the room is unoccupied.

Passive Infrared (PIR) is an excellent and precise technology for initially turning the lights ON, but lacks sensitivity for minor motion at distances. Ultrasonic (U/S) technology provides maximum sensitivity with continuous reflective high frequency waves. This is optimal for keeping the lights ON.

Leviton's multi-technology sensor combines the benefits of both PIR and U/S technologies for unrivaled performance and reliability.

APPLICATIONS

- Cafeterias
- Computer rooms
- Day care centers
- Workspaces
- Offices with cubicles
- Restrooms
- Storage rooms
- Classrooms
- Conference rooms
- Filing rooms
- Open warehouses
- Open areas
- Stairwells
- Executive, open and private offices

FEATURES

- Self-adjusting: internal microprocessor continually analyzes, evaluates and adjusts the sensitivity and time delay. Performance is kept at a maximum and user complaints are eliminated.
- Custom off-white color matched for shaded ceilings
- Fast, simple installation: easy ceiling mount, three wire connection (low voltage) and twist-lock sensor attachment for 360° rotation and flexibility
- Maximum reliability, low cost: digital circuitry uses a minimum of components
- Small motion sensitivity: the ultrasonic technology provides excellent small motion sensitivity
- Timer setting feature: automatic—30sec-30min. Test mode—6sec with auto exit programming.
- Non-volatile memory: learned and adjusted settings saved in protected memory are not lost during power outages
- Walk-through: provides increased energy savings by decreasing the time delay to 2.5min when someone momentarily walks through the monitored space
- Wide coverage: units from 500 to 2,000 sq. ft. available
- Power base (OPB15) available for line voltage applications
- Ambient light recognition: a light sensor prevents lights from turning on when the room is adequately lit by natural light
- Ultrasonic (U/S) components: one or two U/S transducers and one or two narrow bandwidth receivers each 16mm in diameter. Frequency—Crystal controlled to ±.005%.
- Device: rugged, high-impact, injection molded plastic, off -white. Color coded leads 6" (16.24 cm).

HOW THE OSCxx-M AUTOMATICALLY ADAPTS

Condition	Example	Self-Adaptive Reaction
Timer Left In Test Mode - The sensor remains in an 6 sec. test mode.	An installer accidentally leaves the sensor in the 6 sec. timer test mode and the lights may go off or on every 6 sec.	The sensor automatically resets the timer to 10 min after 15 min of test mode.
False-On - The sensor incorrectly turns the lights on.	The sensor detects movement in the corridor or hall way and the room lights turn on.	After an initial movement is sensed, if another movement is not sensed within the timer setting then the delayed off time setting is automatically reduced.
False-Off - The sensor incorrectly turns the lights off.	The sensor does not detect movement because an occupant sits virtually motionless at a desk and the lights turn off.	If motion is sensed within a short period after the lights go off, then the current delayed off-time setting is increased.

Leviton Manufacturing Co., Inc. Global Headquarters

201 North Service Road, Melville, NY 11747-3138 tech line 800-824-3005 fax 800-832-9538

©2016 Leviton Manufacturing Co., Inc. All rights reserved. Subject to change without notice.

PRODUCT DATA

DIP SWITCH SETTINGS			
SWITCH	BANK A	SWITCH FUNCTIONS	SWITCH SETTINGS
		OFF	ON
A1	N/A	Multi-Tech	Single Tech
A2	N/A	PIR	Ultrasonic
A3	Manual Mode	Auto Adapting Enabled	Auto Adapting Disabled
A4	Walk-Thru Disable	Walk-Thru Enabled	Walk-Thru Disabled
		BANK B	
B1	Override to On	Auto Mode	Lights forced On
B2	Override to Off	Auto Mode	Lights forced Off
B3	Test Mode	OFF'ON'OFF	Enter/Exit Test Mode
B4	LED Disable	LEDs Enabled	LEDs Disabled

*Bold items are factory defaults

SPECIFICATIONS

ELECTRICAL	
Frequency	OSC05-M0W, OSC10-M0W: 40kHz OSC20-M0W: 32Khz
Power Requirements	24 VDC, from OSPxx Power Pack or OPB15 Power Base
Power Consumption	OSC05: 25mA, OSC10: 35mA, OSC20: 30mA
Output	24 VDC active high logic control signal with short circuit protection
CONTROLS	
Ultrasonic Sensitivity	0-100%; green knob (factory setting: 50%)
Infrared Sensitivity	0-100%; red knob; (factory setting: 75%)
Light Sensor	20 to 3,000 Lux; blue knob; factory set at 100% (*grey wire required)
Time Delay	30sec-30min; black knob (factory setting: 10min)
INDICATORS	
Green LED	U/S motion technology
Red LED	Infrared motion technology
ENVIRONMENTAL	
Operating Temperature Range	32-104°F (0-40°C)
Relative Humidity	0-95% non-condensing, for indoor use only
OTHER	
Mounting Height	8-12 feet
Listings	CUL/US Certified, meets energy code requirements for ASHRAE Standard 90.1 and CA Title 24
Warranty	Limited Five-Year Warranty
ORDERING INFORMATION	
CAT NO.	DESCRIPTION
OSC05-M0W	Multi-Technology Ceiling Sensor, 500 sq. feet of coverage
OSC10-M0W	Multi-Technology Ceiling Sensor, 1,000 sq. feet of coverage
OSC20-M0W	Multi-Technology Ceiling Sensor, 2,000 sq. feet of coverage

NAFTA compliant and Made in USA models available

DIMENSIONS

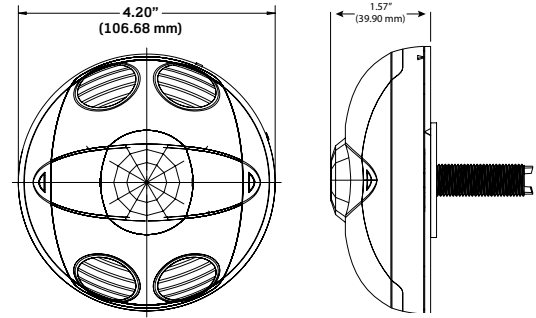

FIELD-OF-VIEW

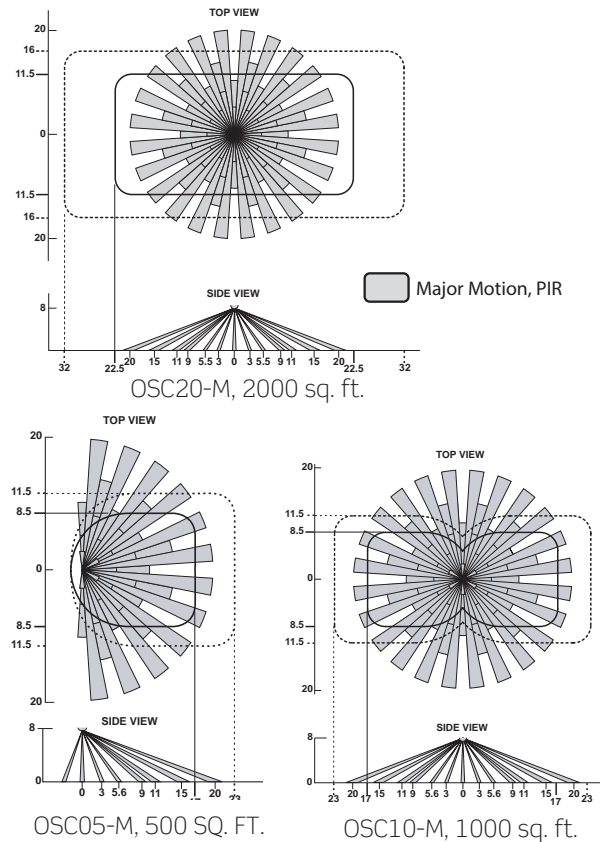

PHYSICAL WIRING

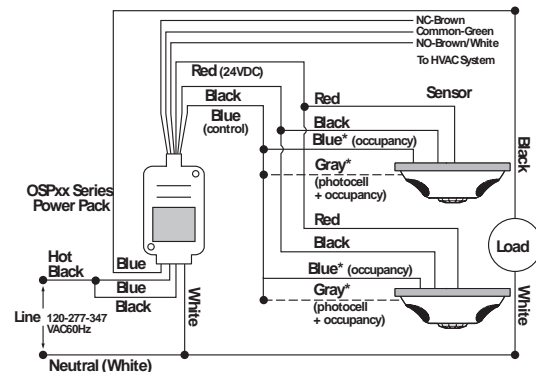

Leviton Manufacturing Co., Inc. Global Headquarters

201 North Service Road, Melville, NY 11747-3138 tel 800-323-8920 fax 800-832-9538 tech line (8:30AM-7:00PM ET Mon-Fri) 800-824-3005

Leviton Manufacturing Co., Inc. Energy Management, Controls and Automation

20497 SW Teton Avenue, Tualatin, OR 97062 tel 800-736-6682 fax 503-404-5594 tech line (6:00AM-4:00PM PT Mon-Fri) 800-959-6004

Visit our Website at: www.leviton.com/sensors

©2016 Leviton Manufacturing Co., Inc. All rights reserved. Subject to change without notice.

G-8357A/F16-aa
REV JUN 2016