

TX6A™ Category 6A UTP Field Term RJ45 Plug

PANDUIT®

SPECIFICATION SHEET

specifications

The TX6A™ Category 6A UTP Field Term RJ45 Plug is a simple-to-attach plug for field termination of 4-pair unshielded twisted pair cable. Providing Category 6A performance the TX6A™ plug is also compatible with Category 6 and 5e systems. The two-piece TX6A™ plug terminates 4-pair, 22 - 26 AWG, 100 ohm unshielded twisted pair cable and uses proven TG-style forward motion termination technology to optimize performance by maintaining cable pair geometry while eliminating conductor untwist.



applications

The simple-to-attach TX6A™ Field-Term Plug is ideal for connecting the increasing number of network-powered devices requiring a plug connection to the network and where field attachment of the plug to UTP cable is desired. Typical applications include:

- Wireless access points (WAPs)
- Power over Ethernet (PoE) LED lighting
- IP security cameras and motion sensors
- Building access control points
- Network-attached Audio/Video equipment
- Other PoE or HDBASE-T powered network devices

technical information

Category 6A/Class E_A performance:	Exceeds ANSI/TIA 568-C.2 Category 6A and ISO 11801 Class E _A Channel performance requirements with up to two field term plugs in channel. Meets or exceeds proposed TIA Modular Plug Terminated Link requirements with up to two field term plugs in link
Cable compatibility:	Compatible with 4-pair, 22–26 AWG solid or stranded unshielded twisted pair cable with conductor insulation diameters of 0.060 in. maximum and overall cable O.D. 0.200 in. to 0.330 in
FCC and ANSI compliance:	Meets ANSI/TIA-1096-A (formerly FCC Part 68)
IEC compliance:	IEC 60603-7, IEC 60529 (IP 20)
RoHS compliance:	Compliant
PoE compliance:	Supports IEEE 802.3af / 802.3at (PoE/PoE+) and proposed 802.3bt type 3 and type 4 (PoE++) applications
Plug mating cycles:	Rated to 2500 mating cycles
UL rated:	UL 1863 (Use as communications circuit accessory) UL 2043 (Suitable for use in air-handling spaces)
Operating temperature:	-10°C to 65°C (14°F to 149°F)
Storage temperature:	-40°C to 70°C (-40°F to 158°F)
Required installation tool:	EGJT-1

key features and benefits

Simple two-piece assembly	Field friendly, easier to handle during field installation, saving time and reducing termination error
Slim plug profile	Easily fits in tight port spaces or high-density port configurations
22-26 AWG termination capable	Works with today's most common UTP cables, including emerging power-optimized 22 AWG cabling
TG-style termination technology	Proven electrical performance and quick installation speed from the same forward-motion termination technology used in Panduit's Mini-Com TG modular jacks
Category 6A, 6, and 5e compatibility	High performance capability and wide cable size range enable a single plug for all common UTP cabling systems
Re-termination	Ability to re-terminate up to 20 times with no additional parts, providing convenience and cost-savings in cases when plug must be re-terminated to cable
Compact termination tool	Foldable tool EGJT-1 is lightweight and robust, making it easy to carry anywhere

www.panduit.com

TX6A™ UTP Field Term Plug

Field Term Plug: FP6X88MTG

Field Term Plug, 10 pack: FP6X88MTG-X

UTP Copper Cables Category 6A Copper Cable

Category 6A UTP: PU*6AM04 series

Category 6 Copper Cable

Category 6 UTP: PU*6004 series
PU*6C04 series

Category 5e Copper Cable

Category 5e UTP: PU*5504 series
PU*5C04 series

Tools and Accessories

Termination Tool: EGJT-1

Wire Stripping Tool: CCAST

Wire Snipping Tool: CWST

Optional Test Cord: FP6X88TC

* Cable flame rating:

C = CM

L = LSZH (IEC 60332-1)

P = Plenum/CMP

R = Riser/CMR

Y = EuroClass C (*Only available for 6C04 Series*)

Z = LSZH (IEC 60332-3) (*Not available for 6C04 Series*)

TX6A™ Category 6A UTP Field Term RJ45 Plug

Dimensions

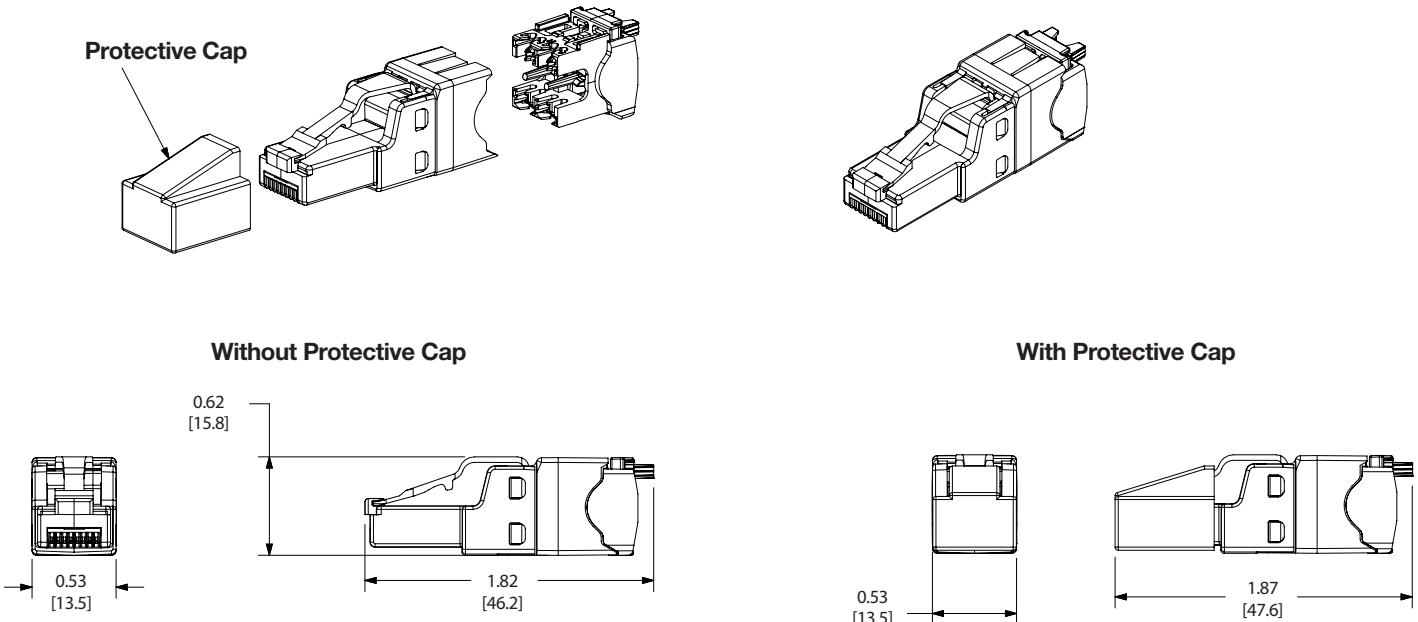

Dimensions are in inches. [Dimensions in brackets are metric.]

WORLDWIDE SUBSIDIARIES AND SALES OFFICES

PANDUIT US/CANADA
Phone: 800.777.3300

PANDUIT EUROPE LTD.
London, UK
Phone: 44.20.8601.7200

PANDUIT SINGAPORE PTE. LTD.
Republic of Singapore
Phone: 65.6305.7575

PANDUIT JAPAN
Tokyo, Japan
Phone: 81.3.6863.6000

PANDUIT LATIN AMERICA
Guadalajara, Mexico
Phone: 52.33.3777.6000

PANDUIT AUSTRALIA PTY. LTD.
Victoria, Australia
Phone: 61.3.9794.9020

For a copy of Panduit product warranties, log on to www.panduit.com/warranty

PANDUIT®

For more information
Visit us at www.panduit.com

© 2017 Panduit Corp.
ALL RIGHTS RESERVED.
COSP412--WW-ENG
7/2017