



**SILENT  
KNIGHT**

by Honeywell

## IntelliKnight® Model EVS-125W

### Intelligent 125 Watt Amplifier

The EVS-125W is an intelligent 125 watt amplifier for use with the 5820XL-EVS. The EVS-125W is used to amplify the audio message for distribution throughout the facility. Since it is designed as a self-contained distributed amplifier it can be conveniently located near the area of protection to reduce wiring demands.

For more information about the EVS-125W, or to locate your nearest source, please call 800-328-0103.

#### Description

Each EVS-125W is capable of producing 125-watts of audio power. Up to four EVS-125Ws can be used on the voice evacuation system. The EVS-125W has its own power supply with battery backup and four speaker circuits which can be expanded to eight speaker circuits with the optional EVS-CE4. The EVS-125W is fully supervised by the main panel for trouble conditions.

#### Features

- SBUS addressable, up to four EVS-125Ws per system.
- Each EVS-125W is supervised and has four onboard audio circuits expandable to eight with the EVS-CE4.
- EVS-125W uses an easy to install wire harness to connect the ECS-CE4 audio circuit expander.
- The EVS-125W has it's own power supply and backup battery.
- Six-wire connection to EVS system: Two-wires for the voice bus and four-wires for the SBUS connections.
- 120 VAC or 240 VAC operation.
- UL 864 and UL 2572.

#### Listings

- UL 864 and UL 2572

Meets the requirements for NFPA 72 Local Protective Signaling Systems & Emergency Communication Systems.

Other Listings:  
CSFM (pending)



**Model EVS-125W**

#### Installation

The EVS-125W can be surface or flush mounted.

#### Compatibility

The EVS-125W is compatible with the following voice evacuation components:

- 5820XL-EVS Voice Integration Panel with Fire Alarm Control

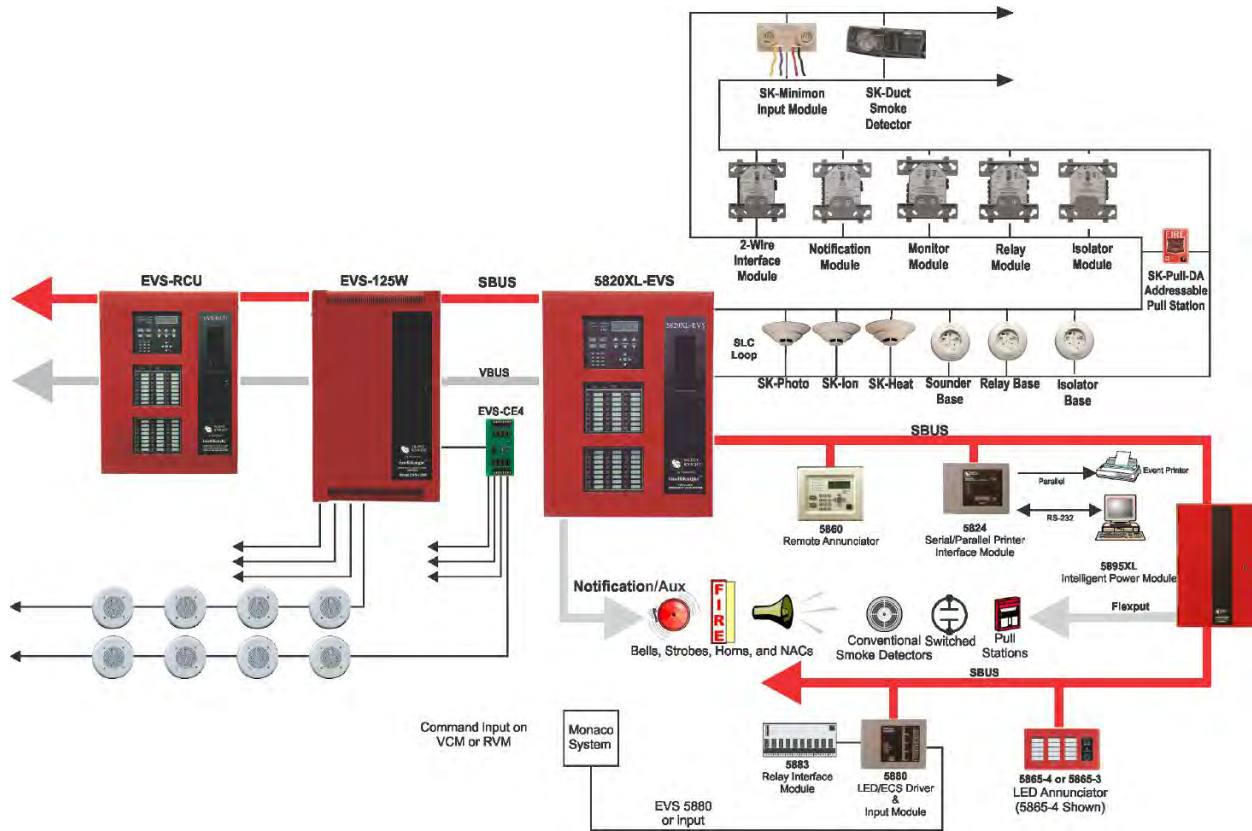

## Specifications

### Physical

Flush Mount Dimensions:  
 14.5"W x 24.75"H x 3.4"D  
 (36.8 W x 62.9 H x 8.7 D cm)

Overall Dimensions:  
 16"W x 26.25"H x 4.1"D  
 (40.6 W x 66.7 H x 10.5 D cm)

Color: Red

### Environmental

Operating Temperature: 32°F – 120°F (0°C – 49°C)  
 Humidity: 10% – 93% non-condensing

### Electrical

Primary AC: 120 VAC @ 60 Hz  
 Standby Current: 375 mA  
 Alarm Current: 700 mA  
 Total Power: 125 W @ 25 VRMS

- Circuit 1: Rated at 100 W each
- Circuit 2-8: Rated at 50 W each
- EVS-CE4 Circuits 5-8: Rated at 50 W each

Main EVS Panel SBUS Standby & Alarm: 10 mA  
 Battery Charging Capacity: 7 – 35 AH

Battery Size: 18 AH max allowed in cabinet. Use RBB accessory cabinet for larger batteries up to 35 AH per system.

### Voice Integration Wiring:

Six conductor  
 Two voice bus  
 Four SBUS

## Ordering Information

EVS-125W Intelligent 125 Watt Amplifier

### Accessories

EVS-CE4 Adds four additional audio circuits to the EVS-125W.

RBB Remote Battery Box Accessory Cabinet. Use for backup batteries up to 35 AH.

AB55 Remote Battery Box Accessory Cabinet Use for back batteries up to 55AH and too large to fit into EVS-50W Cabinet.



This document is not intended to be used for installation purposes. We try to keep our product information up-to-date and accurate. We cannot cover all specific applications or anticipate all requirements. All specifications are subject to change without notice. For more information, contact Silent Knight 12 Clintonville Road, Northford, CT 06472 Phone: (203) 484-7161, Fax: (203) 484-7118. For Technical Support, Please call 800-446-6444.  
[www.silentknight.com](http://www.silentknight.com)

Made in America

PN 350606 Rev A  
 © 2013 Honeywell International Inc.