

Panasonic®

Installation Guide

Included Installation Instructions

Network Camera

Model No. **WV-SW598A / WV-SW397B**
Rain wash coating Rain wash coating

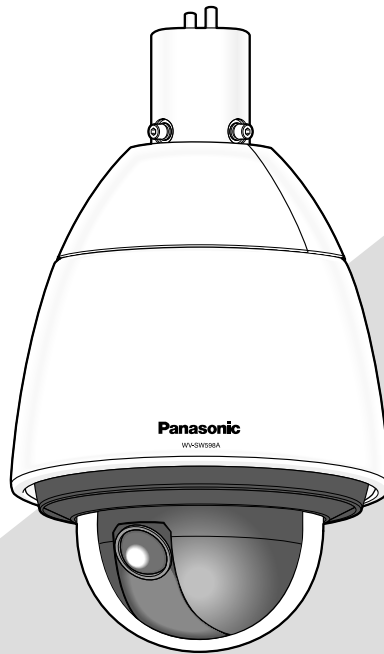

Before attempting to connect or operate this product,
please read these instructions carefully and save this manual for future use.



The model number is abbreviated in some descriptions in this manual.
This manual uses the WV-SW598A as an example in the explanations.

For Europe

We declare under our sole responsibility that the product to which this declaration relates is in conformity with the standard or other normative document following the provisions of Directive 2004/108/EC.

Wir erklären in alleiniger Verantwortung, daß das Produkt, auf das sich diese Erklärung bezieht, mit der folgenden Norm oder normativen Dokument übereinstimmt. Gemäß den Bestimmungen der Richtlinie 2004/108/EC.

Nous déclarons sous notre propre responsabilité que le produit auquel se réfère la présente déclaration est conforme à la norme spécifiée ou à tout autre document normatif conformément aux dispositions de la directive 2004/108/CE.

Nosotros declaramos bajo nuestra única responsabilidad que el producto a que hace referencia esta declaración está conforme con la norma u otro documento normativo siguiendo las estipulaciones de la directiva 2004/108/CE.

Noi dichiariamo sotto nostra esclusiva responsabilità che il prodotto a cui si riferisce la presente dichiarazione risulta conforme al seguente standard o altro documento normativo conforme alle disposizioni della direttiva 2004/108/CE.

Wij verklaren als enige aansprakelijke, dat het product waarop deze verklaring betrekking heeft, voldoet aan de volgende norm of ander normatief document, overeenkomstig de bepalingen van Richtlijn 2004/108/EC.

Vi erklærer os eneansvarlige for, at dette produkt, som denne deklaration omhandler, er i overensstemmelse med standard eller andre normative dokumenter i følge bestemmelserne i direktiv 2004/108/EC.

Vi deklarerar härmed vårt fulla ansvar för att den produkt till vilken denna deklaration hänvisar är i överensstämmelse med standarddokument eller annat normativt dokument som framställs i direktiv 2004/108/EC.

Ilmoitamme yksinomaisella vastuullamme, että tuote, jota tämä ilmoitus koskee, noudattaa seuraavaa standardia tai muuta ohjeellista asiakirjaa, jotka noudattavat direktiivin 2004/108/EC sääöksiä.

Vi erklærer oss alene ansvarlige for at produktet som denne erklæringen gjelder for, er i overensstemmelse med følgende norm eller andre normgivende dokumenter som følger bestemmelsene i direktiv 2004/108/EC.

WARNING:

- To prevent injury, this apparatus must be securely attached to the wall/ceiling in accordance with the installation instructions.
- All work related to the installation of this product should be made by qualified service personnel or system installers.
- The installation shall be carried out in accordance with all applicable installation rules.
- The connections should comply with local electrical code.
- Batteries (battery pack or batteries installed) shall not be exposed to excessive heat such as sunlight, fire or the like.

CAUTION:

- Any changes or modifications not expressly approved by the party responsible for compliance could void the user's authority to operate the equipment.
- The network camera is only intended for a connection to an ethernet or PoE network without routing to the outside plant.

For U.S.A

This product contains a CR Coin Cell Lithium Battery which contains Perchlorate Material - special handling may apply. See www.dtsc.ca.gov/hazardouswaste/perchlorate/

For Canada

CAN ICES-3(A)/NMB-3(A)

For U.S.A

NOTE: This equipment has been tested and found to comply with the limits for a Class A digital device, pursuant to Part 15 of the FCC Rules. These limits are designed to provide reasonable protection against harmful interference when the equipment is operated in a commercial environment. This equipment generates, uses, and can radiate radio frequency energy and, if not installed and used in accordance with the instruction manual, may cause harmful interference to radio communications. Operation of this equipment in a residential area is likely to cause harmful interference in which case the user will be required to correct the interference at his own expense.

FCC Caution: To assure continued compliance, (example - use only shielded interface cables when connecting to computer or peripheral devices). Any changes or modifications not expressly approved by the party responsible for compliance could void the user's authority to operate this equipment.

For U.S.A

The model number and serial number of this product may be found on the surface of the unit. You should note the model number and serial number of this unit in the space provided and retain this book as a permanent record of your purchase to aid identification in the event of theft.

Model No. _____

Serial No. _____

Contents

| | |
|---|----|
| Important safety instructions..... | 4 |
| Limitation of liability..... | 5 |
| Disclaimer of warranty..... | 5 |
| Preface | 5 |
| About notations | 5 |
| Main functions | 6 |
| About the user manuals | 7 |
| System requirements for a PC | 7 |
| Trademarks and registered trademarks..... | 8 |
| Copyright..... | 8 |
| Network security | 8 |
| Precautions | 9 |
| Precautions for installation..... | 13 |
| Major operating controls | 15 |
| Initialize the camera..... | 17 |
| Insert/remove an SD memory card* | 18 |
| Installations/Connections..... | 20 |
| Configure the network settings | 31 |
| Troubleshooting..... | 33 |
| Specifications..... | 36 |
| Standard accessories..... | 39 |
| Optional accessories..... | 39 |

* SDXC/SDHC/SD memory card is described as SD memory card.

Important safety instructions

- 1) Read these instructions.
- 2) Keep these instructions.
- 3) Heed all warnings.
- 4) Follow all instructions.
- 5) Do not install near any heat sources such as radiators, heat registers, stoves, or other apparatus (including amplifiers) that produce heat.
- 6) Only use attachments/accessories specified by the manufacturer.
- 7) Use only with the cart, stand, tripod, bracket, or table specified by the manufacturer, or sold with the apparatus. When a cart is used, use caution when moving the cart/apparatus combination to avoid injury from tip-over.



- 8) Unplug this apparatus during lightning storms or when unused for long periods of time.
- 9) Refer all servicing to qualified service personnel. Servicing is required when the apparatus has been damaged in any way, such as power-supply cord or plug is damaged, liquid has been spilled or objects have fallen into the apparatus, the apparatus has been exposed to rain or moisture, does not operate normally, or has been dropped.

Limitation of liability

THIS PUBLICATION IS PROVIDED "AS IS" WITHOUT WARRANTY OF ANY KIND, EITHER EXPRESS OR IMPLIED, INCLUDING BUT NOT LIMITED TO, THE IMPLIED WARRANTIES OF MERCHANTABILITY, FITNESS FOR ANY PARTICULAR PURPOSE, OR NON-INFRINGEMENT OF THE THIRD PARTY'S RIGHT.

THIS PUBLICATION COULD INCLUDE TECHNICAL INACCURACIES OR TYPOGRAPHICAL ERRORS. CHANGES ARE ADDED TO THE INFORMATION HEREIN, AT ANY TIME, FOR THE IMPROVEMENTS OF THIS PUBLICATION AND/OR THE CORRESPONDING PRODUCT (S).

Disclaimer of warranty

IN NO EVENT SHALL Panasonic System Networks Co., Ltd. BE LIABLE TO ANY PARTY OR ANY PERSON, EXCEPT FOR REPLACEMENT OR REASONABLE MAINTENANCE OF THE PRODUCT, FOR THE CASES, INCLUDING BUT NOT LIMITED TO BELOW:

- (1) ANY DAMAGE AND LOSS, INCLUDING WITHOUT LIMITATION, DIRECT OR INDIRECT, SPECIAL, CONSEQUENTIAL OR EXEMPLARY, ARISING OUT OF OR RELATING TO THE PRODUCT;
- (2) ANY INCONVENIENCE, LOSS, OR DAMAGE CAUSED BY INAPPROPRIATE USE OR NEGLIGENT OPERATION OF THE USER;
- (3) ALL MALFUNCTIONS OR TROUBLES FROM UNAUTHORIZED DISASSEMBLE, REPAIR OR MODIFICATION OF THE PRODUCT BY THE USER, REGARDLESS OF THE CAUSE OF THE MALFUNCTION OR TROUBLE;
- (4) INCONVENIENCE OR ANY LOSS ARISING WHEN IMAGES ARE NOT DISPLAYED, DUE TO ANY REASON OR CAUSE INCLUDING ANY FAILURE OR PROBLEM OF THE PRODUCT;
- (5) ANY PROBLEM, CONSEQUENTIAL INCONVENIENCE, OR LOSS OR DAMAGE, ARISING OUT OF THE SYSTEM COMBINED BY THE DEVICES OF THIRD PARTY;
- (6) ANY CLAIM OR ACTION FOR DAMAGES, BROUGHT BY ANY PERSON OR ORGANIZATION BEING A PHOTOGENIC SUBJECT, DUE TO VIOLATION OF PRIVACY WITH THE RESULT OF THAT SURVEILLANCE-CAMERA'S PICTURE, INCLUDING SAVED DATA, FOR SOME REASON, BECOMES PUBLIC OR IS USED FOR ANY PURPOSE;
- (7) LOSS OF REGISTERED DATA CAUSED BY ANY FAILURE.

Preface

The network camera WV-SW598A or WV-SW397B is designed to operate using a PC on a network (10BASE-T/100BASE-TX).

By connecting to a network (LAN) or the Internet, images and audio from the camera can be monitored on a PC via a network.

Note:

- It is necessary to configure the network settings of the PC and its network environment to monitor images from the camera on the PC. It is also necessary to install a web browser on the PC.
-

About notations

The following notations are used when describing the functions limited for specified models.

The functions without the notations are supported by all models.

<Outdoor Vandal resistant & waterproof FULL-HD model> Rain wash coating

SW598A: The functions with this notation are available when using the model WV-SW598A.

<Outdoor Vandal resistant & waterproof HD model> Rain wash coating

SW397B: The functions with this notation are available when using the model WV-SW397B.

Main functions

H.264 dual stream and JPEG (MJPEG) triple encoding

H.264 dual stream output and JPEG (MJPEG) output can be simultaneously provided.

* H.264 stream1: 1920x1080/ max. 30 fps (SW598A)
1280x720/ max. 30 fps (SW397B)

H.264 stream2: 640x360/ max. 30 fps

Super Dynamic (MEGA Super Dynamic)

(☞ Operating Instructions (included in the CD-ROM))

MEGA Super Dynamic compensates brightness on a pixel-to-pixel basis so that it produces clearer images even if objects have various illumination intensities.

Day & Night function

Images will be displayed clear even at night since the camera will be automatically switched from the color mode to the black and white mode under low illumination condition.

30x optical zoom and high accuracy preset position function

A single camera provides wide area monitoring.

In 1280x720 mode up to 45x HD Extra Optical Zoom is possible. (SW397B)

In 640x360 mode up to 90x Extra Optical Zoom is possible. (SW598A)

The camera can be installed not only on the ceiling but also on the wall

When using a mounting bracket (option or custom-made), pendant-type installation on a ceiling or mounting on a wall is available.

Dome cover with rain wash coating

The rain wash coating is a special coating applied to the surface of the dome cover that makes it hard for water droplets to adhere to the dome cover.

* The rain wash coating is only effective against water (rain water) and is not intended to be used to protect the surface of the dome cover from other substances such as oil.

Power over Ethernet Plus function (Power over Ethernet Plus power reception. Referred to from here on as PoE+.)

Power can be supplied to the camera by simply connecting it to an IEEE802.3at compliant PoE+ (Power over Ethernet Plus) device with a LAN cable. Furthermore, by using a tested PoE injector, power can be supplied to the camera in extremely low temperature outdoor environments that get as cold as -50°C $\{-58^{\circ}\text{F}\}$.

* For information on tested PoE injectors (60 W), contact your dealer or access the following website.

<http://security.panasonic.com/pss/security/support/info.html>

SDXC/SDHC/SD memory card slot equipped

It is possible to save H.264 videos and JPEG images on the SDXC/SDHC/SD memory card manually at an alarm occurrence, during the period of the schedule, or from a web browser. It is also possible to save JPEG images at a network failure occurrence (download is possible).

(Recommended SDXC/SDHC/SD memory cards ☞ page 39)

Auto tracking function with smooth changing between panning, tilting and zoom

It is possible to perform smooth changing between panning, tilting and zoom.

* The accuracy with the auto tracking function depends on the installation location. Make sure that the installation location is appropriate in advance.

The camera conforms to the IP66^{*1} and Type 4X (UL50)^{*2}, is compliant with NEMA 4X^{*3} ratings, and provides high dust resistance and waterproof performance. (SW598A)

The camera conforms to the IP66^{*1} and Type 4 (UL50)^{*2}, is compliant with NEMA 4^{*3} ratings, and provides high dust resistance and waterproof performance. (SW397B)

Waterproofing treatment is not required for the camera body (waterproofing treatment is required for cable connections).

*1 IP66 rating: The applicable product has "Dust tight (6)" protection against foreign solids and has "Powerful water jets (6)" protection against water (IEC60529).

*2 UL50 is a waterproofing standard regulated by UL, and Type 4X indicates the waterproofing class.

*3 NEMA: Dust resistance and waterproof performance standards set by National Electrical Manufacturers Association (United States).

About the user manuals

There are 2 sets of operating instructions for the WV-SW598A, WV-SW397B as follows.

- Installation Guide: Explains how to install and connect devices, as well as how to connect and configure the network.
- Operating Instructions (included in the CD-ROM): Explains how to perform the settings and how to operate this camera.

Adobe® Reader® is required to read these operating instructions on the provided CD-ROM.

When the Adobe Reader is not installed on the PC, download the latest Adobe Reader from the Adobe web site and install it.

The external appearance and other parts shown in this manual may differ from the actual product within the scope that will not interfere with normal use due to improvement of the product.

English screens are used in these operating instructions.

System requirements for a PC

| | |
|--------------------|--|
| CPU: | Intel® Core™ 2 Duo 2.4 GHz or faster recommended |
| Memory: | A minimum of 1 GB memory (32-bit), 2 GB (64-bit) are required when using Microsoft® Windows® 8.1, Microsoft® Windows® 8, Microsoft® Windows® 7 A minimum of 1 GB memory is required when using Microsoft®, Windows Vista® |
| Network interface: | 10BASE-T/100BASE-TX 1 port |
| Audio interface: | Sound card (when using the audio function) |
| Monitor: | Image capture size: 1024x768 pixels or more Color: 24-bit True color or better |
| OS: | Microsoft® Windows® 8.1 Microsoft® Windows® 8 Microsoft® Windows® 7 Microsoft® Windows Vista® |
| Web browser: | Windows® Internet Explorer® 11 (32-bit) Windows® Internet Explorer® 10 (32-bit) Windows® Internet Explorer® 9 (32-bit) Windows® Internet Explorer® 8 (32-bit) Windows® Internet Explorer® 7 (32-bit) |
| Others: | CD-ROM drive (It is necessary to read the operating instructions and use the software on the provided CD-ROM.) Adobe® Reader® (It is necessary to view the PDF file on the provided CD-ROM.) |

IMPORTANT:

- For information on the operation verification of the supported operating systems and web browsers, refer to our web-site at <http://security.panasonic.com/pss/security/support/info.html>.
- When using a PC that does not meet the above requirements, displaying of images may become slower or the web browser may become inoperable.
- Audio may not be heard if a sound card is not installed on a PC. Audio may be interrupted depending on the network environment.
- Microsoft Windows RT and Microsoft Windows 7 Starter are not supported.
- When using Microsoft Windows 8.1 and Microsoft Windows 8, use it in the desktop. The software cannot be used in the Modern UI design.

Note:

- For further information about PC system requirements and precautions for when using Microsoft Windows 8.1, Microsoft Windows 8, Microsoft Windows 7, Microsoft Windows Vista, or Windows Internet Explorer, click "Manual" - "Open" from the supplied CD-ROM and refer to "Notes on Windows® / Internet Explorer® versions".
-

Trademarks and registered trademarks

- Microsoft, Windows, Windows Vista, Windows Media, Internet Explorer, and DirectX are either registered trademarks or trademarks of Microsoft Corporation in the United States and/or other countries.
- Microsoft product screen shot(s) reprinted with permission from Microsoft Corporation.
- Intel and Intel Core are trademarks of Intel Corporation in the U.S. and other countries.
- Adobe, Acrobat Reader, and Reader are either registered trademarks or trademarks of Adobe Systems Incorporated in the United States and/or other countries.
- SDXC Logo is a trademark of SD-3C, LLC.
- iPad, iPhone, and iPod touch are trademarks of Apple Inc., registered in the U.S. and other countries.
- Android is a trademark of Google Inc.
- All other trademarks identified herein are the property of their respective owners.

Copyright

Distributing, copying, disassembling, reverse compiling and reverse engineering of the software provided with this product are all expressly prohibited. In addition, exporting any software provided with this product violating export laws is prohibited.

Network security

As you will use this unit connected to a network, your attention is called to the following security risks.

- ① Leakage or theft of information through this unit
- ② Use of this unit for illegal operations by persons with malicious intent
- ③ Interference with or stoppage of this unit by persons with malicious intent

It is your responsibility to take precautions such as those described below to protect yourself against the above network security risks.

- Use this unit in a network secured by a firewall, etc.
- If this unit is connected to a network that includes PCs, make sure that the system is not infected by computer viruses or other malicious entities (using a regularly updated anti-virus program, anti-spyware program, etc.).
- Protect your network against unauthorized access by restricting users to those who log in with an authorized user name and password.
- Apply measures such as user authentication to protect your network against leakage or theft of information, including image data, authentication information (user names and passwords), alarm mail information, FTP server information and DDNS server information.
- After the unit is accessed by the administrator, make sure to close the browser.
- Change the administrator password periodically.
- Do not install the camera in locations where the camera or the cables can be destroyed or damaged by persons with malicious intent.

Precautions

Refer installation work to the dealer.

Installation work requires technique and experience. Failure to observe this may cause fire, electric shock, injury, or damage to the product. Be sure to consult the dealer.

Stop the operation immediately when something is wrong with this product.

When smoke goes up from the product, the smell of smoke comes from the product, or the exterior of the product has deteriorated, continued use will cause a fire or fall of the product resulting in injury, or damage to the product.

In this case, turn the power off immediately and contact qualified service personnel for service.

Do not attempt to disassemble or modify this product.

Failure to observe this may cause fire or electric shock. Consult the dealer for the repair or inspections.

Do not insert any foreign objects.

Fire or electrical shock may be caused if water or any foreign objects, such as metal objects, enter inside the unit. Turn the power off immediately and contact qualified service personnel for service.

Select an installation area that can support the total weight.

Selecting an inappropriate installation surface may cause this product to fall down or topple over, resulting in injury or accidents. Installation work shall be started after sufficient reinforcement.

Periodic inspections shall be conducted.

Rust on the metal parts or screws may cause a fall of the product resulting in injury or accidents. Consult the dealer for the inspections.

Do not use this product in an inflammable atmosphere.

Failure to observe this may cause an explosion resulting in injury.

Avoid installing this product in the locations where salt damage occurs or corrosive gas is produced.

Otherwise, the mounting portions will deteriorate and accidents such as a fall of the product may occur.

The measures of protection against a fall of this product shall be taken.

Failure to observe this may cause a drop resulting in injury or accidents. Be sure to install the safety wire.

The exclusively designed mount bracket shall be used.

Failure to observe this may cause a drop resulting in injury or accidents. Use the exclusively designed mount bracket for installation.

The screws and bolts must be tightened to the specified torque.

Failure to observe this may cause a drop resulting in injury or accidents.

Do not install this product in locations subject to vibration.

Loosening of mounting screws or bolts may cause a fall of the product resulting in injury or accidents.

Do not strike or give a strong shock to this product.

Failure to observe this may cause fire or injury.

Turn the power off when do wiring of this product.

Failure to observe this may cause electric shock. In addition, short circuit or wrong wiring may cause fire.

Do not touch the main body while this product is panning/tilting.

Fingers may be caught up in the moving part, and that may result in injury.

Keep SDXC/SDHC/SD memory cards away from infants and children.

Otherwise, they may swallow the cards by mistake. In this case, consult a doctor immediately.

Do not install or clean the camera, or touch this product, the power cable or the connected cables during thunder storms.

Failure to observe this may cause electric shock.

Install this product in a location high enough to avoid people and objects from bumping the product.

Failure to observe this may cause injury.

Do not hang down from this product or use this product as a pedestal.

Failure to observe this may cause a drop resulting in accidents.

Do not damage the power cable.

Do not damage, fabricate, twist, stretch, bundle, or forcibly bend the power cable. Do not place heavy objects on it, and keep it away from heat sources.

Use of a damaged power cable may cause electric shock, short circuit, or fire.

Consult the dealer for repair.

Do not install this product on a place that is greatly influenced by wind.

Installation on a place where the wind speed is 60 m {196.85 feet} or more per second may cause a fall of the product resulting in injury or accidents.

The measures of protection against snowfall shall be taken.

Weight of snow may cause a fall of the product resulting in injury or accidents.

Protect the product against snowfall by installing it under eaves.

Correctly perform all wiring

Short circuits in the wiring or incorrect wiring may cause fire or electrical shock.

Turn the power off when cleaning this product.

Failure to observe this may cause injury.

Do not rub the edges of metal parts with your hand.

Failure to observe this may cause injury.

[Precautions for use]**This product has no power switch.**

When turning off the power, disconnect the power supply from the 24 V AC power supply or the PoE+ device.

To keep on using with stable performance

Do not use this product in hot and humid conditions for a long time. Failure to observe this causes component degradation resulting in life shortening of this product.

Do not expose this product to direct heat sources such as a heater.

Handle this product with care.

Do not drop this product, nor apply shock or vibration to the product. Failure to observe this may cause trouble.

Do not give a strong shock to the dome cover.

It may cause damage or water exposure.

About the battery

A battery is installed inside the camera.

Do not leave the battery exposed in environments of excessive heat as a result of sunlight or fire.

About the PC monitor

When displaying the same image on the PC monitor for a long time, the PC monitor may be damaged.

It is recommended to use a screen-saver.

When an error is detected, this product will restart automatically.

This product will be inoperable for around 2 minutes after the restart just as when the power is turned on.

Product disposal/transfer

Data saved on this product or a storage device used with this product may lead to personal information leakage.

When it is necessary to dispose or give this product to someone, even when for repair, make sure that there is no data on this product.

When disposing a storage device, it is recommended that all stored data is deleted using a PC and then physically dismantled.

Do not touch the dome cover with your bare hands.

The rain wash coating is applied to the surface of the dome cover. Do not directly touch the surface of the dome cover or wipe it with a cloth or other product. Failure to observe this may reduce the effectiveness of the rain wash coating.

Cleaning this product body

Be sure to turn off the power before cleaning.

- When cleaning the dome cover, wash away any dirt or other unwanted substances by pouring or spraying clean water from a hose or spray bottle (do not wipe the dome cover with a cloth or other product). Do not use benzine, thinner, alcohol, or any other types of solvents or detergents.

IMPORTANT:

- Improper cleaning of the dome cover may cause the rain wash coating to become less effective. In this case, in order to have effective rain wash coating, a new dome cover must be purchased to replace the existing dome cover. Consult with your dealer or construction contractor.

IMPORTANT:

- The camera position may be moved inadvertently while cleaning the camera body. Restart the product or refresh the camera position (position refresh) to correct the camera position. Refer to the Operating Instructions on the provided CD-ROM for further information.
-

Transmission interval

Image transmission interval may become slow depending on the network environment, PC performance, shooting subject, access number, etc.

Periodically images on the screen appear to be distorted

When the camera is installed in a location where it is subject to small vibrations (for example, when it is installed near devices that vibrate), images may appear distorted and stretched lengthways. This phenomenon is a characteristic of image pickup devices that use CMOS sensors and is caused by the relationship between the periodic movements of the camera and the timing that the image sensor reads images. This is not a problem with the camera. To reduce the possibility of this phenomenon occurring, install the camera in a secure location.

What to do if "WARMING UP-PLEASE WAIT" appears on the display.

This message indicates that the temperature inside the camera has become extremely low.

In such a case, wait until the heater unit of the camera raises the internal temperature (for around 2 hours or more in low temperatures below -10°C { 14°F }), and turn on the power again.

About SD memory card

- Before removing the SD memory card, make sure to select "Not use" for "SD memory card" on the [SD memory card] tab of "Basic" page on the setup menu first. (☞ Operating Instructions (included in the CD-ROM)) Refer to page 18 for descriptions of how to insert/remove an SD memory card.
- When using an unformatted SD memory card, format it using this product. Recorded data on the SD memory card will be deleted when formatted. If an unformatted SD memory card or an SD memory card formatted with other devices is used, this product may not work properly or performance deterioration may be caused. Refer to the Operating Instructions on the provided CD-ROM for how to format an SD memory card.
- When some SD memory cards are used with this product, the product may not work properly or performance deterioration may be caused. Use the SD memory cards recommended in page 39.

Panasonic will not make restitution of any content which could not be recorded or edited properly due to malfunction of this product or the SD memory card and also assumes no responsibility for the loss of any recorded or edited content and or the direct or indirect damage due to this loss.

Code label

The code labels (accessory) are required at inquiry for trouble. Use caution not to lose these labels. It is recommended to paste one of the labels onto the CD-ROM case.

About the MOS image sensor

- When continuously shooting a bright light source such as a spotlight, the color filter of the MOS image sensor may become deteriorated and this may cause discoloration. Even when changing the fixed shooting direction after continuously shooting a spotlight for a certain period, the discoloration may remain.
- When shooting fast-moving subjects or performing panning/tilting operations, objects crossing the shooting area may look to be bending askew.

AVC Patent Portfolio License

THIS PRODUCT IS LICENSED UNDER THE AVC PATENT PORTFOLIO LICENSE FOR THE PERSONAL USE OF A CONSUMER OR OTHER USES IN WHICH IT DOES NOT RECEIVE REMUNERATION TO (i) ENCODE VIDEO IN COMPLIANCE WITH THE AVC STANDARD ("AVC VIDEO") AND/OR (ii) DECODE AVC VIDEO THAT WAS ENCODED BY A CONSUMER ENGAGED IN A PERSONAL ACTIVITY AND/OR WAS OBTAINED FROM A VIDEO PROVIDER LICENSED TO PROVIDE AVC VIDEO. NO LICENSE IS GRANTED OR SHALL BE IMPLIED FOR ANY OTHER USE. ADDITIONAL INFORMATION MAY BE OBTAINED FROM MPEG LA, L.L.C. SEE [HTTP://WWW.MPEGLA.COM](http://www.mpegla.com)

Consumable parts

The following are consumables: Replace them in accordance with their operating lifetimes. Their operating lifetimes vary depending on the usage environment and conditions. The operating lifetimes below are just guides for when using the camera at $+35^{\circ}\text{C}$ { 95°F }.

- Lens unit, panning motor, tilting motor, flat cable for tilting: Approx. 3.7 million operations (Approx. 20000 hours)
Cooling fan: Approx. 52000 hours
Slip ring: Approx. 3.7 million operations (Approx. 20000 hours)

About the automatic status detection function

When this product malfunctions due to exogenous noise, etc. for 30 seconds or more, the product will automatically reset and will return to normal state. When the product is reset, initialization will be carried out as when the power of the product is turned on. When the product repeatedly resets, exogenous noise level around the product may be high and that may cause malfunction. Contact your dealer for instructions.

About the dehumidifying device

This product has dehumidifying device to keep the inside at low moisture level, preventing condensation and quickly dissipating dew if produced.

Dew may be produced depending on the conditions of temperature, humidity, winds, and rain, and it may take time to dehumidify.

Lens and pan/tilt head

If a lens and pan/tilt head are not performed for a long period of time, the grease coating inside these parts may become sticky. That may obstruct the parts from moving. To prevent this, move the lens or pan/tilt head periodically. Or perform position refresh periodically in the manner described in "Position refresh".

Position refresh

During the use for a long period of time, the preset positions may become inaccurate. When "Position refresh" is set for the created schedule, the camera position will be corrected periodically.

Refer to the Operating Instructions on the provided CD-ROM for how to perform the settings.

Tilt angles and the zoom ratio

This product contains a function to prevent image deterioration when using a tilt angle higher than horizontal (0° to -15°). However, when this product is used at a tilt angle higher than about -5° , depending on the zoom rate used, images may become distorted or the upper parts of the images may become dark. In this case, adjust the zoom rate or tilt angle as necessary.

Equipment classification and power source indication label

Remove the main sunshield rear cover of this product to refer to the indication label for the equipment classification and power source, etc.

: **Direct current symbol**

: **Alternating current symbol**

Precautions for installation

Panasonic assumes no responsibility for injuries or property damage resulting from failures arising out of improper installation or operation inconsistent with this documentation.

Power supply

This product has no power switch.

When turning off the power, turn off a power supply or remove a power cable. When the power cable of the product is connected to the power supply device, the power will be supplied to the product. When the product is supplied, the product will perform panning, tilting, zooming and focusing.

Before cleaning the product, make sure that the power cable is not connected to the main power supply.

Installation area for this product

Select an appropriate place for the installation area (such as a strong wall or ceiling) in your particular environment.

- When hanging the camera from a ceiling, use the WV-Q121B (option) ceiling mount bracket.
- When installing on a wall, use wall mount bracket WV-Q122 (option).
- When pendant-mounting on a ceiling on a bracket that is custom-made, use the attachment pipe.
- When this product and camera mount bracket are mounted on a ceiling or a wall, use the screws described in page 20. The screws that secure the product are not supplied. Prepare them according to the material and strength of the area where the product is to be installed.
- Do not mount the product on a plaster board or a wooden section because they are too weak. If the product is unavoidably mounted on such a section, the section shall be sufficiently reinforced.

When using the camera in combination with an attachment pipe and attaching to a locally procured bracket

- Locally procure a M6 eye bolt (stainless steel). Recommended tightening torque: 2.45 N m {1.8 lbf-ft}
- In order to prevent the camera from falling, procure a bracket that can be attached a safety wire.
- Connect the M6 eye bolt and locally procured bracket together with the safety wire.
- Check that the surface that the attachment pipe and locally procured bracket are to be attached to can bear the weight of the bracket and camera.

Mounting method for this product

This product is designed to be used as a pendant mount camera. If the product is mounted on a desktop or at a slant, it may not work correctly and its lifetime may be shortened.

Protection from lightning

When cables are used outdoors, there is a chance that they may be affected by lightning. In such a case, install a lightning arrester close to the camera, and make the length of the network cable between the camera and lightning arrester as short as possible to prevent the camera from being damaged by lightning.

Do not place this product in the following places:

- Locations where a chemical agent is used such as a swimming pool
- Locations subject to moisture or oil smoke such as a kitchen
- Locations that have a specific environment that is subject to an inflammable atmosphere or solvents
- Locations where a radiation, an X-ray, a strong radio wave or a strong magnetic field is generated
- Locations where corrosive gas is produced, locations where it may be damaged by briny air such as sea-shores
- Locations where the temperature is not within the specified range (☞ page 36)
- Locations subject to vibrations, such as on vehicles, marine vessels, or above product lines (This product is not designed for on-vehicle use.)
- Locations subject to condensation as the result of severe changes in temperature (In case of installing the product in such locations, the dome cover may become foggy or condensation may be caused on the cover.)

Screw tightening

- The screws and bolts must be tightened with an appropriate tightening torque according to the material and strength of the installation area.
- Do not use an impact driver. Use of an impact driver may damage the screws or cause tightening excessively.
- When a screw is tightened, make the screw at a right angle to the surface. After tightening the screws or bolts, perform checks to ensure that the tightening is sufficient enough so that there is no movement or looseness.

Remove the Protection Cover from the dome cover after the installation is complete.

Make sure to remove this product if it will no longer be used.

When noise disturbance may happen

Conduct the power distribution work to keep a distance of 1 m {3.28 feet} or more from the 120 V (for U.S. and Canada) or 220 V - 240 V (for Europe and other countries) power line. Or conduct the electric conduit work separately.

Radio disturbance

When this product is used near TV/radio antenna, strong electric field or magnetic field (near a motor, a transformer or a power line), images may be distorted and noise may be produced.

Take notice of humidity.

Install this product when the humidity is low. If this product is installed during rainfall or when there is high humidity, the inside may be exposed to moisture and the dome cover may become foggy.

Heater unit

This product is equipped with an internal heater unit for use in cold climates. The product can be used in temperatures as low as $-30\text{ }^{\circ}\text{C}$ $\{-22\text{ }^{\circ}\text{F}\}$ when connected to a PoE+ hub and $-50\text{ }^{\circ}\text{C}$ $\{-58\text{ }^{\circ}\text{F}\}$ when connected to a 24 V AC power supply or a tested PoE injector. The heater unit turns on automatically when the temperature inside the product drops below $+10\text{ }^{\circ}\text{C}$ $\{50\text{ }^{\circ}\text{F}\}$. However, in an extremely low-temperature environment below $-30\text{ }^{\circ}\text{C}$ $\{-22\text{ }^{\circ}\text{F}\}$, snow and frost may not be defrosted from the dome cover. When using the product in cold climates, take notice of the ambient and internal temperatures of the product.

When this product is installed and operated in low temperatures below $-10\text{ }^{\circ}\text{C}$ $\{14\text{ }^{\circ}\text{F}\}$, normal images may not be obtained immediately after startup. In such a case, wait around 2 hours or more, and turn on the power again.

Influence on images and their quality

This product has no wiper unit. Under the following conditions, image quality may deteriorate or images may not be viewed properly.

(1) Influence by rainfall

Due to the wind that accompanies rainfall, images may be less viewable.

(2) Influence by snowfall

Due to the wind that accompanies snowfall, snow may fall on the dome cover. Images may not be able to be viewed through the areas of the dome that have snow on it. (The visibility may vary depending on the amount and type of snow.)

(3) Influence by dust in the air or gas emission from vehicles

Depending on the installation environment, dome cover may become dirty due to dust in the air or gas emission from vehicles. This may degrade the quality of images.

Check before installation

Compatibility of devices is restricted. Before installation, check the ratings and dimensions of the devices to be used.

Contact your dealer for details.

Router

When connecting this product to the Internet, use a broadband router with the port forwarding function (NAT, IP masquerade).

Refer to the Operating Instructions on the provided CD-ROM for further information about the port forwarding function.

PoE+ (Power over Ethernet Plus)

Use a PoE+ hub/device that is compliant with IEEE802.3at standard.

It is impossible to supply the power to this product from a PoE hub that is compliant with IEEE802.3af standard.

Time & date setting

It is necessary to set the time & date before putting this product into operation. Refer to the Operating Instructions on the provided CD-ROM for descriptions of how to perform the settings.

Major operating controls

<Main body>

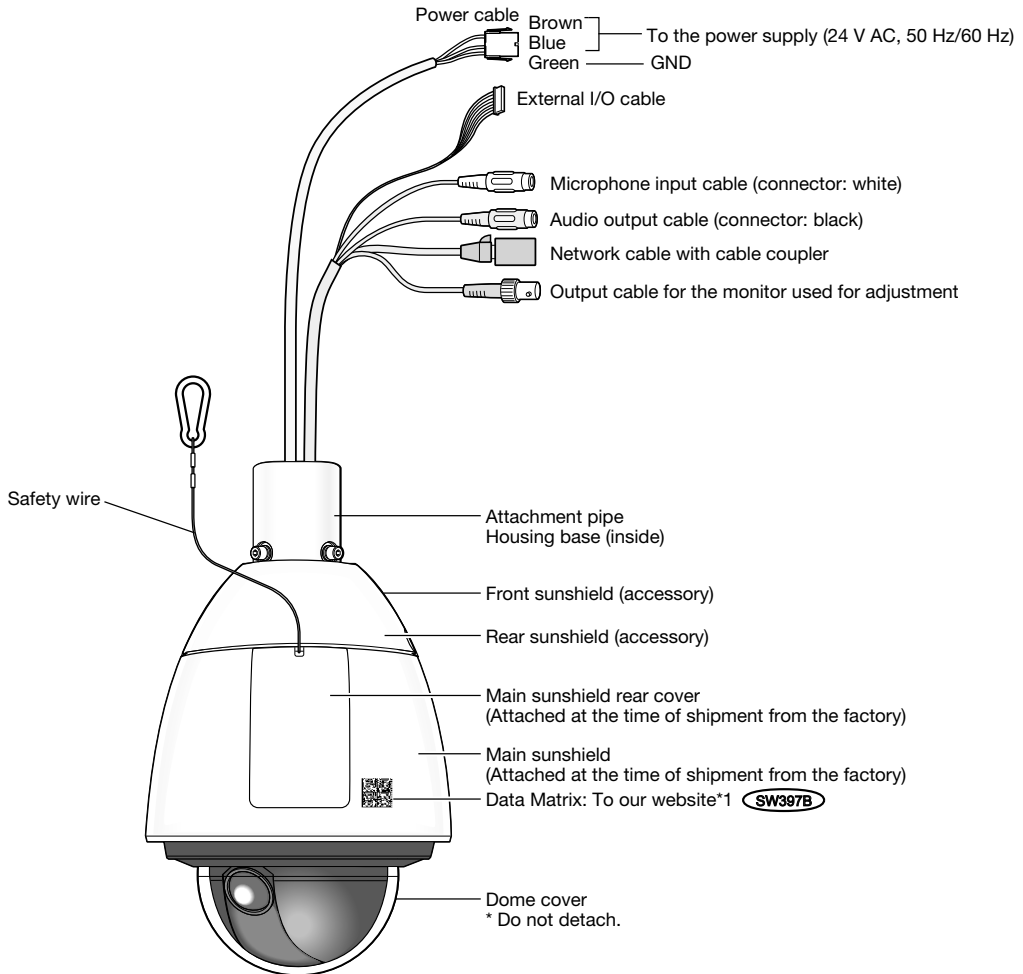

*1 Data Matrix is our website address converted into a two-dimensional barcode. Depending on the scanning application used, the Data Matrix may not be able to be read correctly. In this case, access the site by directly entering the following URL.

http://security.panasonic.com/pss/security/support/qr_sp_select.html

<Rear view of the main body with the main sunshield rear cover detached>

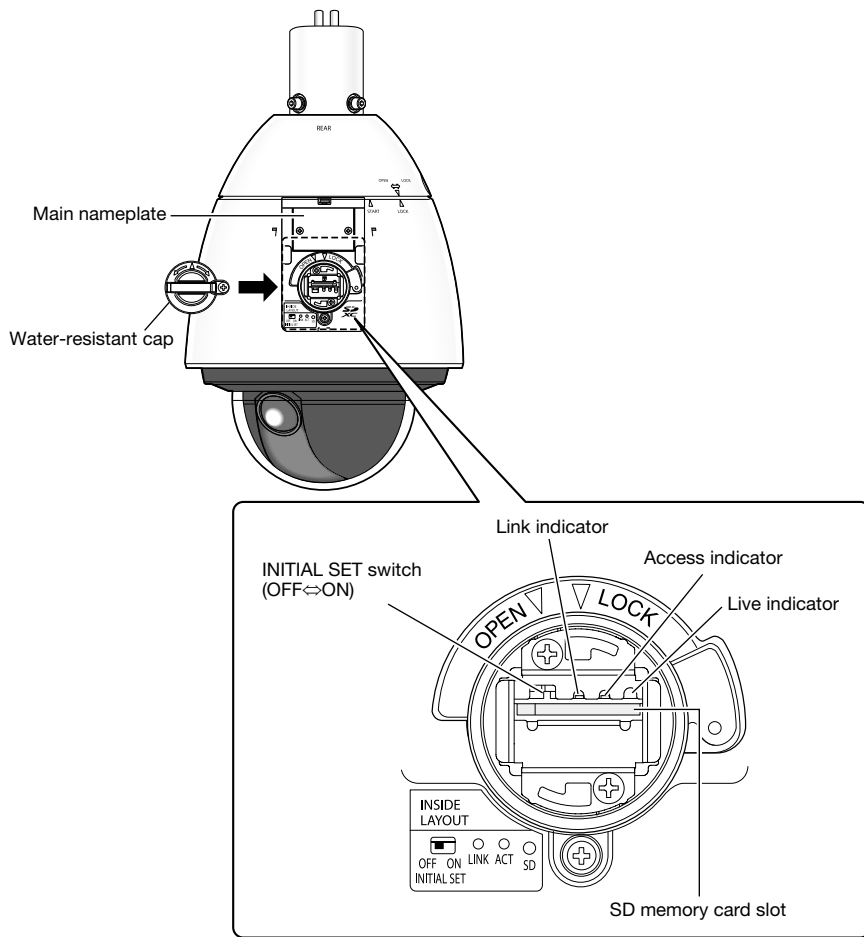

Initialize the camera

Use the INITIAL SET switch to reset the settings of the camera to the default.

IMPORTANT:

- The settings including the network settings will be initialized. Note that the preset position settings and the CRT key (SSL encryption key) used for the HTTPS protocol will not be initialized.

Step 1

Pull out the water-resistant cap by following steps 1 - 3 of the “How to insert an SD memory card” section (☞ page 18).

Step 2

Move the INITIAL SET switch to the right (ON).
The factory default is OFF.

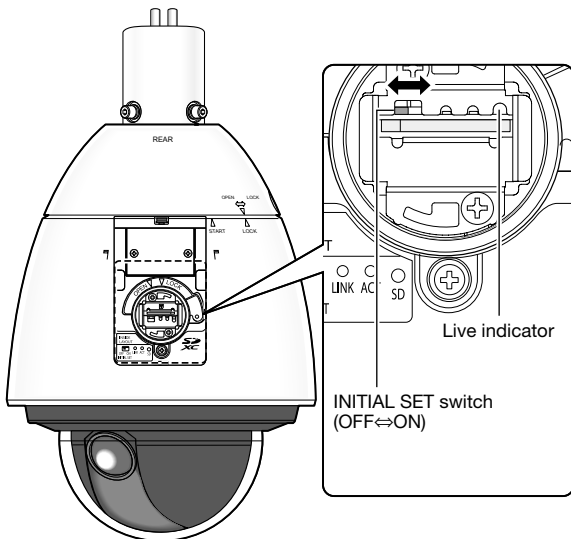

Step 3

Move the INITIAL SET switch to the right, and then turn on the power of the camera. The camera will start up and all the settings including the network settings will be initialized. The live indicator will light orange → light off → blink orange → light orange. The initialization will be complete when the live indicator lights orange. Before initializing the settings, it is recommended to write down the settings in advance.

IMPORTANT:

- Do not turn off the power of the camera during initialization. Otherwise, it may fail to initialize and may cause malfunction.

Step 4

Turn off the power of the camera.

Step 5

Move the INITIAL SET switch to the left (OFF).
(Refer to the illustration in Step 2)

IMPORTANT:

- If the Initial set switch is positioned to the “ON” side, the camera cannot enter the normal operation mode. Be sure to return the INITIAL SET switch to the “OFF” position.

Step 6

Return the water-resistant cap and the main sunshield rear cover to the original state by following steps 5 - 7 of the “How to insert an SD memory card” section (☞ page 19).

Step 7

Turn on the power of the camera. (☞ page 13: Power supply)
When the power is supplied, the camera will enter the normal operation mode.

Insert/remove an SD memory card

How to insert an SD memory card

IMPORTANT:

- When inserting an SD memory card, make sure the direction.

Step 1

Pull out the main sunshield rear cover on the rear of the camera by pressing the tab on the top of the sunshield.

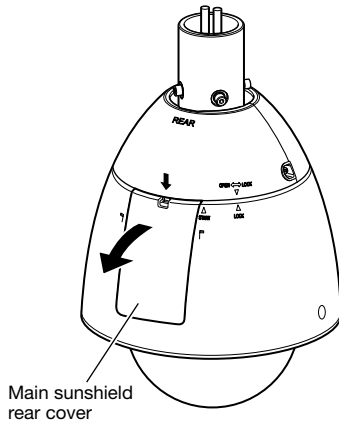

Step 2

Remove the locking screw of the water-resistant cap.

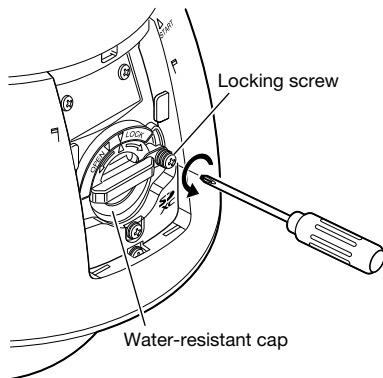

Step 3

Turn the water-resistant cap to the "OPEN" side, and pull out the cap.

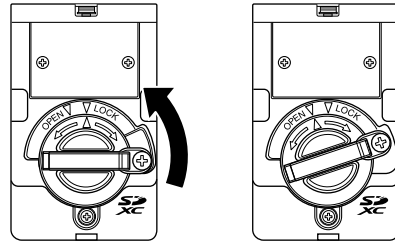

Step 4

Insert an SD memory card into the SD memory card slot. Push the memory card straight into the slot until a click is heard.

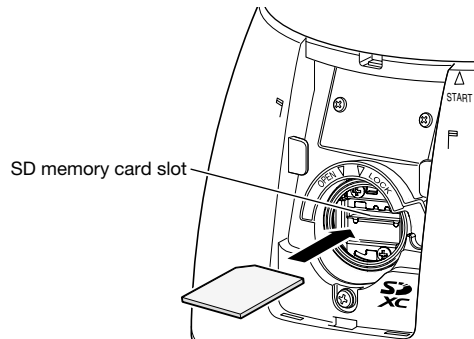

Step 5

Align “△” of the water-resistant cap to “OPEN ▽” of the camera. Then, turn the water-resistant cap toward “▽ LOCK” until the water-resistant cap is secured to the camera.

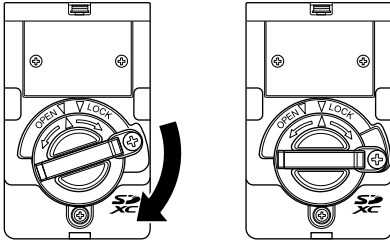

Step 6

Secure the water-resistant cap with the locking screw.
(Recommended tightening torque: 0.69 N·m {0.51 lbf-ft})

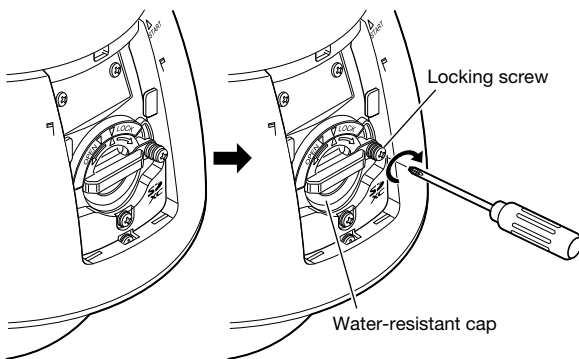

Step 7

First, insert the tab on the bottom of the main sunshield rear cover into the main body, and then push the tab on the top of the main sunshield rear cover into the main body until a click is heard.

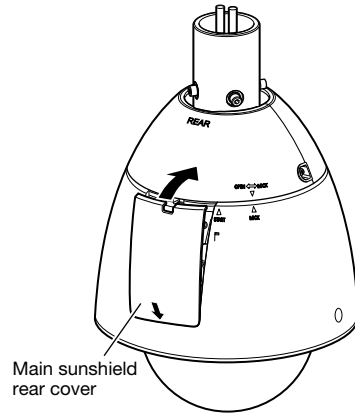

Step 8

Turn on the power of the camera, and select “Use” for “SD memory card” on the [SD memory card] tab of the “Basic” page on the setup menu. (☞ Operating Instructions (included in the CD-ROM))

Step 9

Format the SD memory card by clicking the [Execute] button of “Format” on the [SD memory card] tab of the “Basic” page on the setup menu. (☞ Operating Instructions (included in the CD-ROM))

How to remove the SD memory card

IMPORTANT:

- Before removing the SD memory card, make sure to select “Not use” for “SD memory card” on the [SD memory card] tab of “Basic” page on the setup menu first.
(☞ Operating Instructions (included in the CD-ROM))

Step 1

Remove the water-resistant cap by following steps 1 - 3 of the “How to insert an SD memory card” section (☞ page 18).

Step 2

Push the SD memory card to release the lock. The SD memory card will come up from the slot.

Step 3

Return the parts to the original state by following steps 5 - 7 of the “How to insert an SD memory card” section (☞ page 19).

Installations/Connections

Caution:

- ONLY CONNECT 24 V AC CLASS 2 POWER SUPPLY (UL 1310/CSA 223) or LIMITED POWER SOURCE (IEC/EN/UL/CSA 60950-1).

Before installation, prepare the following

- When mounting this camera to a ceiling, mount it using the ceiling mount bracket (WV-Q121B) (option) or a custom-made ceiling mount bracket and the attachment pipe (attached to the camera). Refer to page 22 for the specifications of the custom-made ceiling mount bracket.
- When mounting the camera to a wall, use the wall mount bracket WV-Q122 (option).
- * When using the ceiling mount bracket (WV-Q121B) or the wall mount bracket (WV-Q122), do not use the attachment pipe, use the 4 hexagon screws (M6) removed from the attachment pipe and directly fix the housing base to the ceiling mount bracket or the wall mount bracket.
- * If you do not use the wall mount bracket (WV-Q122) and instead use a custom-made wall mount bracket, follow the above directions for the ceiling mount bracket and mount the camera using the attachment pipe.

Refer to the installation guide of the bracket to be used for details on the installation procedures of the bracket and the camera.

IMPORTANT:

- When using the ceiling mount bracket (WV-Q121B) or the wall mount bracket WV-Q122, the hexagon screws (M6) that are accessories of these brackets cannot be used as the mounting screws for this camera. Use the hexagon screws (M5) attached to the housing base.
- When using the ceiling mount bracket (WV-Q121B), use 4 M10 size screws that have a pull-out capacity of at least 1411 N {317 lbf}.
- When using the wall mount bracket (WV-Q122), use 4 M8 size screws that have a pull-out capacity of at least 823 N {185 lbf}. When using the wall mount bracket (WV-Q122A), use 4 M10 size screws that have same pull-out capacity.
- When using a custom-made mount bracket, use screws and anchors that are capable of supporting the combined weight of the camera (approx. 5 kg {11.02 lbs}) and the mount bracket.
- Select screws and anchors that match the type of ceiling or wall that the camera will be mounted to.

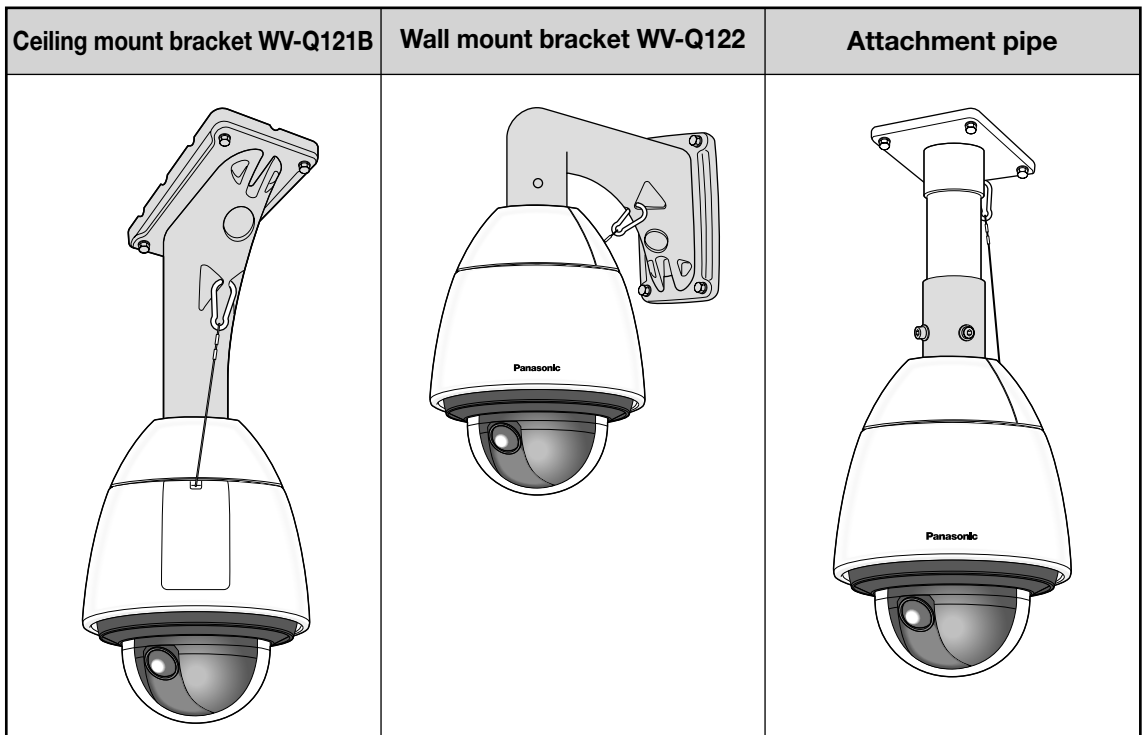

How to detach the housing base

Before attaching the camera to the ceiling mount bracket, the wall mount bracket or a custom-made mount bracket, detach the housing base and attachment pipe from the camera so that installation and connections can be performed.

Step 1

Remove the fixing screws (3 pcs.*) that are securing the housing base and the camera.

The removed screws will be required when attaching the camera to the housing base. Use caution not to lose these screws.

* Special screw (Fixing screw): These screws are hexagon screws. Use an M5 hexagon wrench.

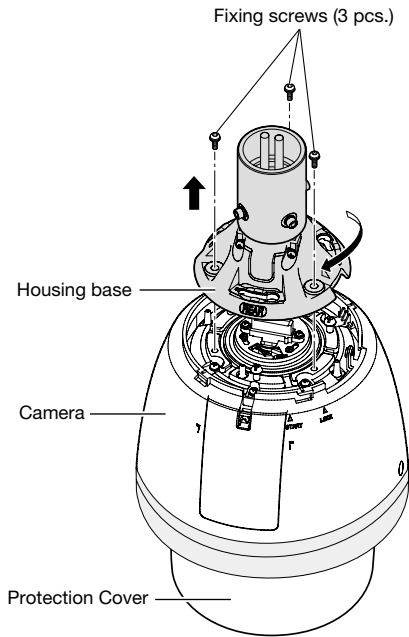

Step 2

To separate the housing base from the camera, turn the housing base to the direction of the arrow as illustrated. (Refer to the illustration in Step 1)

Step 3

Remove the attachment pipe from the housing base by loosening 4 screws.

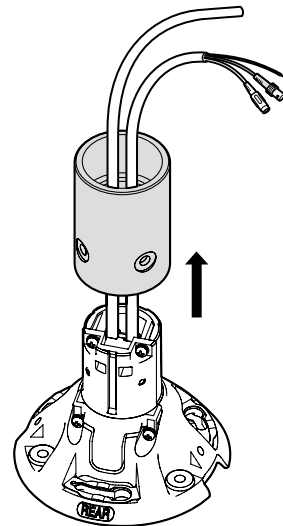
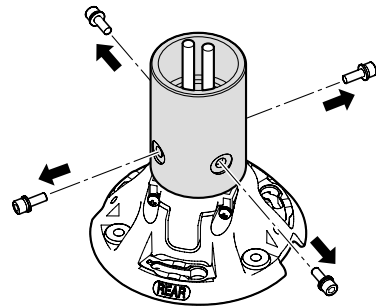

Note:

- If the front and rear sunshields (accessory) are attached to the camera, detach them by performing steps 5 - 7 of "Installation" in the reverse order. (☞ pages 24 and 25)

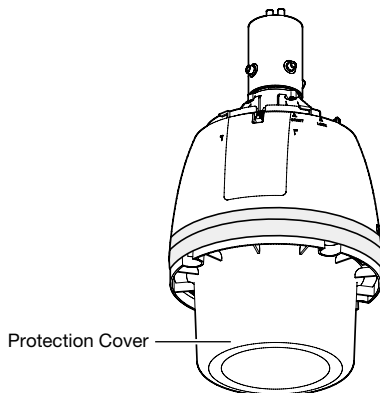

IMPORTANT:

- Remove the Protection Cover from the camera after the installation is complete.

Installation

Before starting installation/connection, make sure that the power cable is not connected to the main power supply. Refer to the "Precautions for installation" section before starting installation/connection. (☞ page 13)

Step 1

Install the mounting bracket.

When using the ceiling mount bracket (WV-Q121B) or the wall mount bracket WV-Q122 (option).

Pass the cables from the housing base through the ceiling mount bracket or the wall mount bracket and connect the cables from the housing base with the cables from the ceiling or wall. Refer to page 26 for how to connect the cables. Refer to the installation guide of each bracket for details on the installation procedure. Take care of the direction to install the mount bracket so that the camera can be mounted at the front of the bracket.

When using the mount bracket (custom-made).

The figure shows an example of the camera mounted on a ceiling with a bracket.

When waterproofing, use waterproof material to fill in gaps and holes between the attachment pipe and the mount bracket.

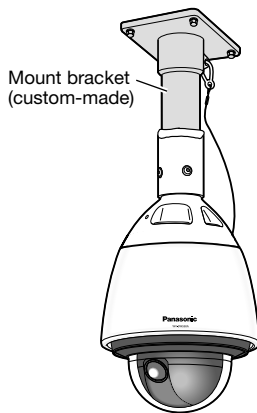

- ① Prepare a ceiling mount bracket.

R 1-1/2, 11crest, deep 30 MAX
(taper pipe thread)

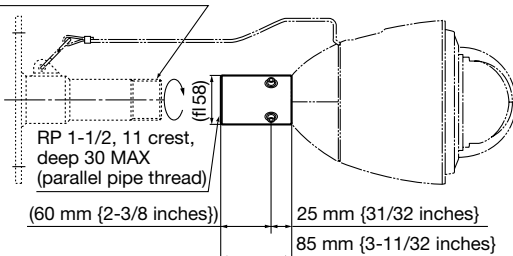

- ② Fix the attachment pipe to the bracket.
- ③ Fill the gap between the bracket and attachment pipe with waterproof material such as silicon clay.

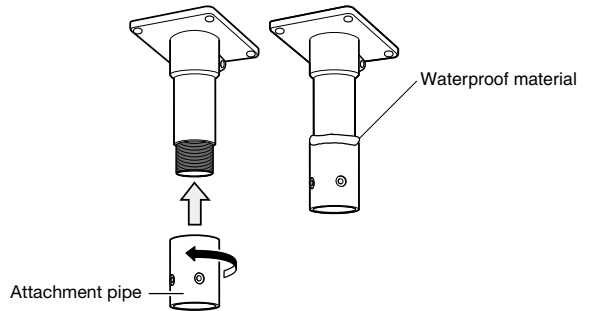

- ④ Pass the cables from the housing base through the mount bracket (custom-made)
- ⑤ Connect the cables from the housing base with the cables from the ceiling or wall. Refer to page 26 for how to connect the cables.

Step 2

Fix a bracket to the installation surface on the ceiling or wall by using appropriate bolts, nuts or the like (not supplied).

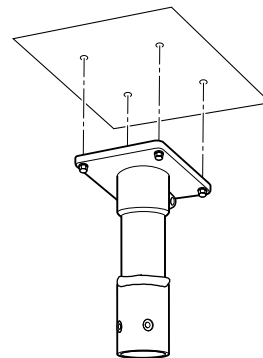

Step 3

Insert the SD memory card into the SD memory card slot. Refer to page 18 for how to insert the SD memory card.

Step 4

Mount the camera to the bracket.

- ① Attach the housing base to the mount bracket using the hexagon screws (M5, 4 pcs.) attached to the housing base*.

(Recommended tightening torque: 2.45 N·m {1.81 lbf·ft})

The "REAR" mark of the housing base shall be directed to the wire hook section.

* Special screw: These screws are hexagon screws. Use an M5 hexagon wrench.

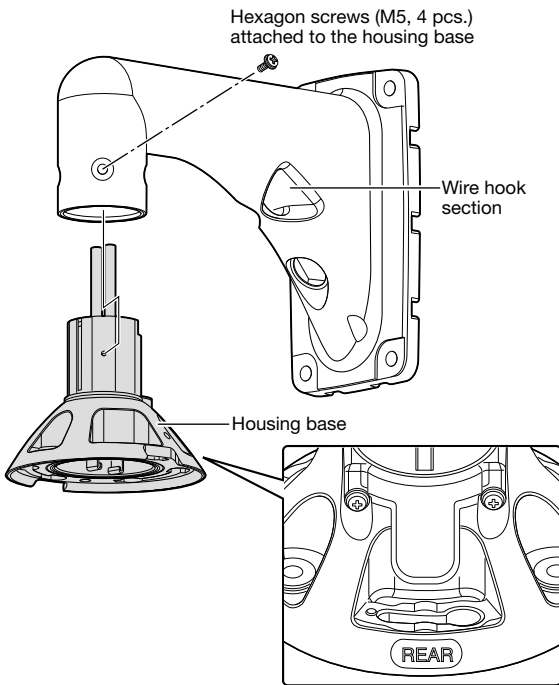

- ② Make sure that the projection of the plate spring on the upper side of the camera is located on the "START" position. If not, turn the plate clockwise to locate the projection at the "START" position.

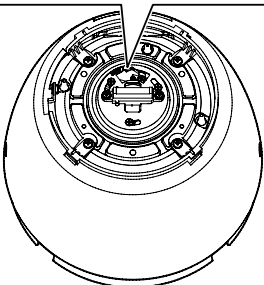
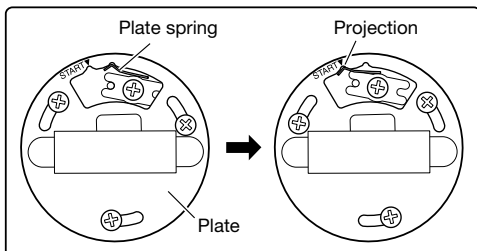

- ③ Connect the safety wire (comes with the camera) to the mount bracket.

Refer to the operating instructions of each mount bracket for further information about where to connect the safety wire.

When using the ceiling mount bracket (WV-Q121B) (option) or the wall mount bracket WV-Q122, connect the safety wire near to the camera as shown in the example below.

<Installation example>

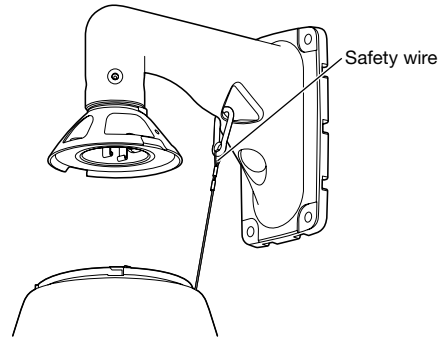

- ④ Attach the camera to the housing base. When attaching the camera to the housing base, the positioning pin on the upper side of the camera shall be on the "REAR" side. Make sure that the camera is securely attached to the mount bracket by turning the camera to the direction of the arrow as illustrated. Then, secure the camera to the mount bracket with the screws* removed when detaching the housing base. (Recommended tightening torque: 2.45 N·m {1.81 lbf·ft})

* Special screw (Fixing screw): These screws are hexagon screws. Use an M5 hexagon wrench.

Overhead view

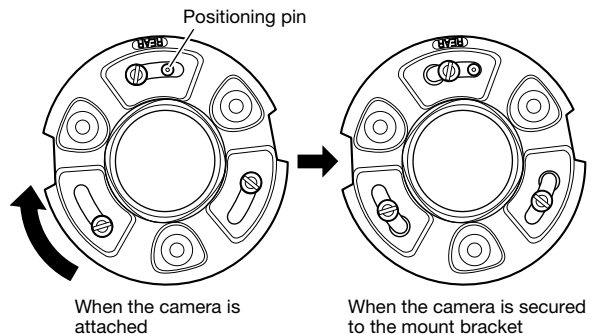

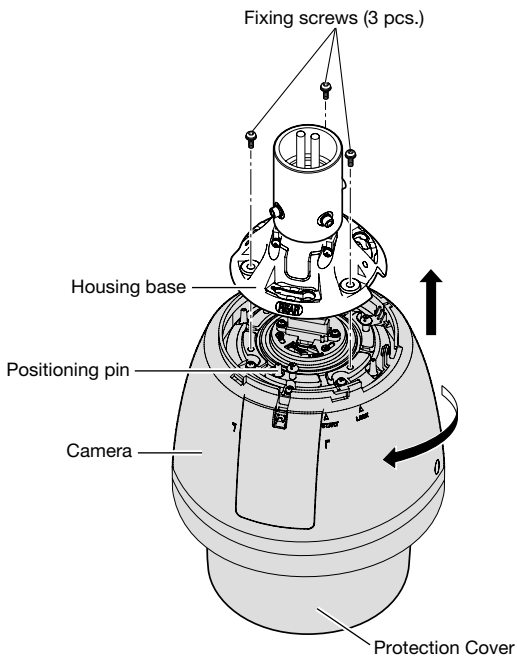

Step 5

Attach the front and rear sunshields (accessory) to the camera.

- Put the fingers on the dents of the front and rear sunshields to detach the hooks. The sunshields will be divided into two parts.

For loss prevention, one side of the front and rear sunshields are linked together with a wire.

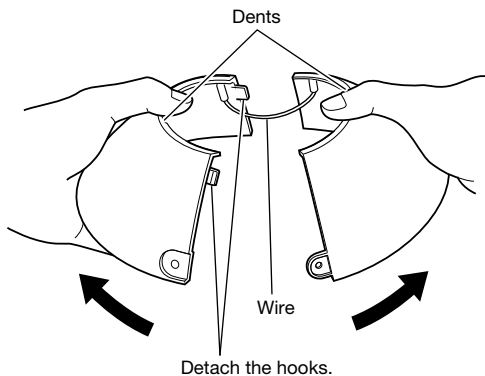

- Locate the front and rear sunshields to the position that covers the housing base.

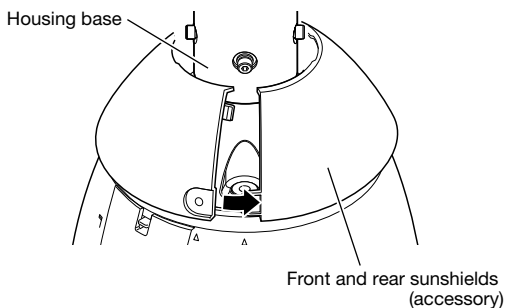

- Joint both sides of front and rear sunshields. Joint the hook and dent on the linked side, and then joint the other side.

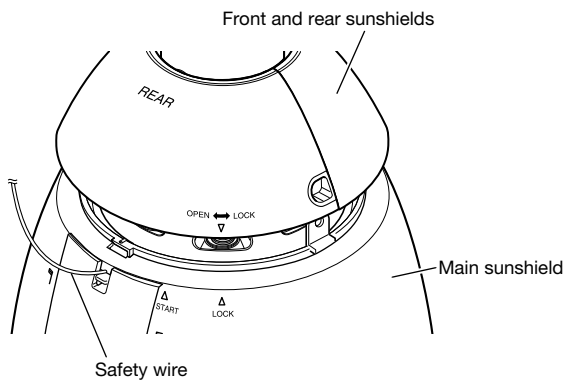

IMPORTANT:

- Joint both sides of the front and rear sunshields before fitting in the main sunshield.
- Do not trap the safety wire inside.
- The safety wire is designed to support only the weight of the camera when the camera falls. Do not put an excessive weight that the safety wire cannot support.

Step 6

Fit the front and rear sunshields in the main sunshield. Align "▽" of the rear sunshield to "△ START" of the main sunshield. Then, turn the front and rear sunshields toward "△ LOCK" until a click is heard.

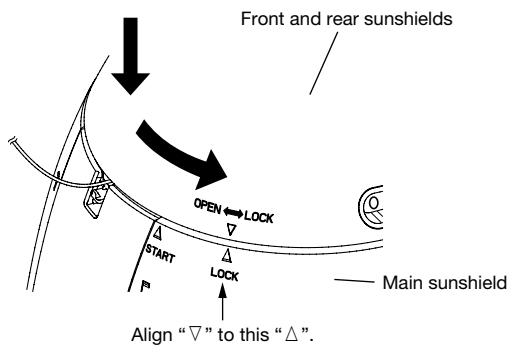

Step 7

Fix the front and rear sunshields on the camera using the front/rear sunshields fixing screw (accessory).
(Recommended tightening torque: 0.72 N·m {0.53 lbf·ft})

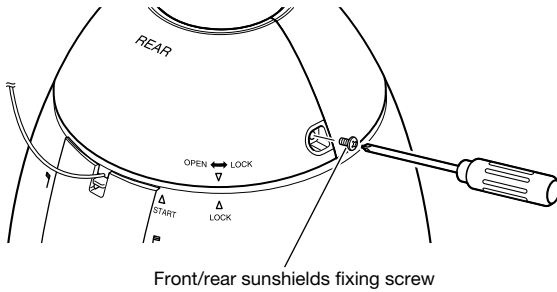

Note:

- When removing the front and rear sunshields, perform steps 5 - 7 in the reverse order. (Refer to pages 24 and 25)

Step 8

After the installation is completed, remove the tape wrapped around the camera while holding the Protection Cover, and then take off the Protection Cover.

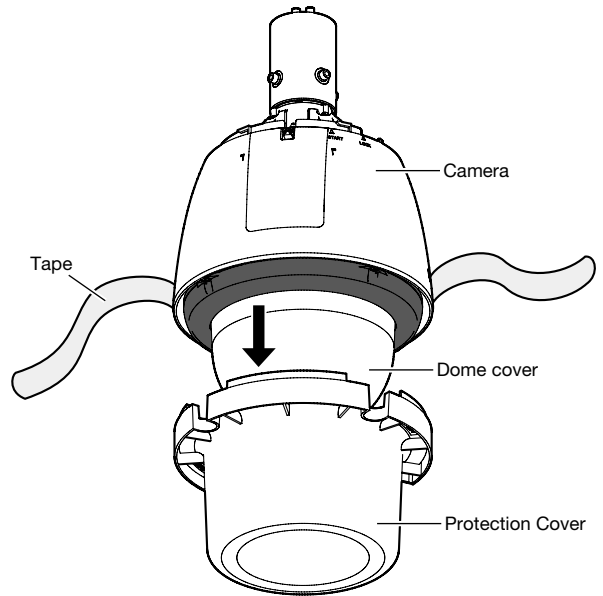

Precautions

- The rain wash coating is applied to the surface of the dome cover. Do not directly touch the surface of the dome cover or wipe it with a cloth or other product. Also, prevent sweat dropping on or spitting on the cover. Failure to observe this may reduce the effectiveness of the rain wash coating.
- When cleaning the dome cover, wash away any dirt or other unwanted substances by pouring or spraying clean water from a hose or spray bottle*1 (do not wipe the dome cover with a cloth or other product). Do not use benzine, thinner, alcohol, or any other types of solvents or detergents.
- Improper cleaning of the dome cover may cause the rain wash coating to become less effective. In this case, in order to have effective rain wash coating, a new dome cover must be purchased to replace the existing dome cover. Consult with your dealer.
- Attach the "Caution label" carried by the camera to the surface of the production (Refer to the illustration).

Protection Cover
PGKV1116

取扱注意ラベル Caution label 使用注意标签

製品外観などに貼付けてください
Please put on the side of the product.
请贴至产品外观处

ドームカバーに触れないこと
Do not touch the dome cover.
请勿触摸球形罩



*1 Note that foreign objects may be mixed into water depending on the container, and it may result in reducing the effectiveness of the rain wash coating. Do not use the spray bottle equipped with a handle or a function to adjust the way of spraying, since the lubricant agent may be mixed into water.

Connection

Caution:

- Before starting connections, make sure that the power connection (24 V AC power cord or LAN cable) is disconnected. Failure to observe this may cause fire, electric shock, injury, or damage to the product.
- A READILY ACCESSIBLE DISCONNECT DEVICE SHALL BE INCORPORATED TO THE EQUIPMENT POWERED BY 24 V AC POWER SUPPLY.

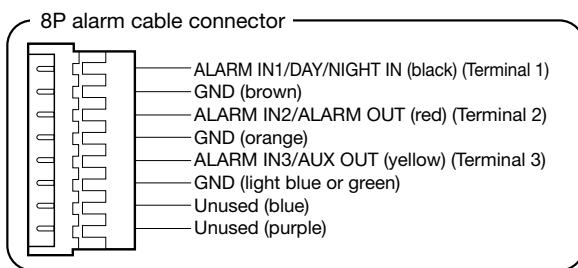
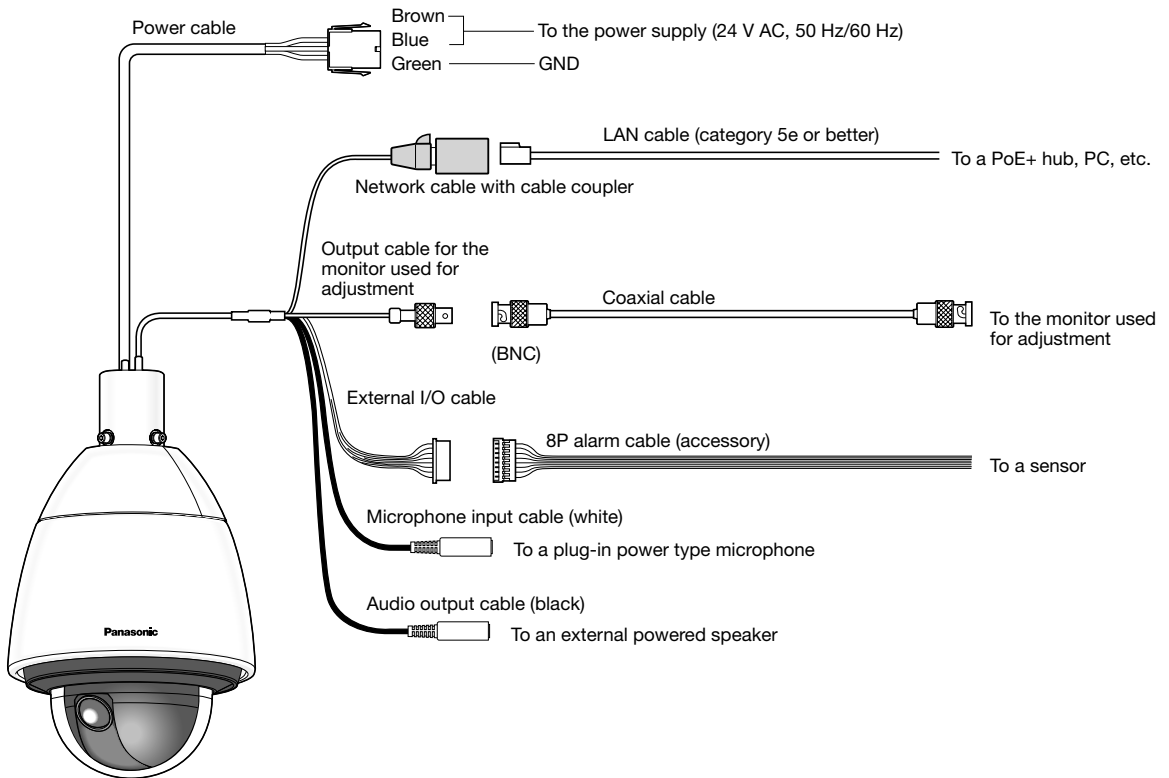

• Output cable for the monitor used for adjustment

The video output is set to NTSC in the default settings of the camera. If you want to change the video output setting to PAL, refer to the Operating Instructions on the provided CD-ROM.

• Power cable

Connect the power cable to the 24 V AC power supply using the 24 V AC power supply connector kit (accessory).

IMPORTANT:

- The power supply of 24 V AC shall be insulated against 120 V AC (for U.S. and Canada) or 220 V - 240 V AC (for Europe and other countries).
- Do not cut or process the network cable since the power is superimposed when using a PoE+ device for power supply. Besides, do not put an excessive weight on connected sections.
- The network camera is only intended for a connection to an ethernet or PoE+ network without routing to the outside plant.

• **24 V AC power supply connector kit (accessory)**

Recommended specification of cable (wire)

| AWG size (stranded wire) | #24 (0.22 mm ²) | #22 (0.33 mm ²) | #20 (0.52 mm ²) | #18 (0.83 mm ²) |
|--------------------------|-----------------------------|-----------------------------|-----------------------------|-----------------------------|
| Length of cable | 20 m {65.62 feet} | 30 m {98.43 feet} | 45 m {147.64 feet} | 75 m {246.06 feet} |

Power supply connector housing (accessory)

| Pin No. | Signal |
|---------|------------------------|
| 1 | 24 V AC LIVE (Brown) |
| 2 | 24 V AC NEUTRAL (Blue) |
| 3 | Ground (Green) |
| 4 | Not use |

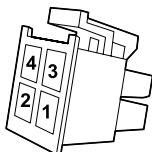

• **How to assemble the 24 V AC power supply connector kit**

Remove approx. 3 mm {1/8 inches} of the outer jacket of the cable and twist the cable core to prevent the short circuit first.

Insert the tip of the cable into the point A of the contact (accessory), and hold the cable using the cable clamp.

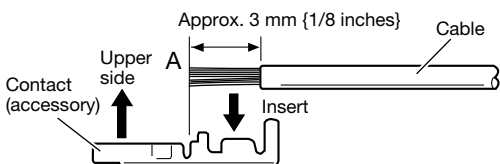

Procure either of the following tools for clamping.

Molex manual clamp tool:

57027-5000 (for UL1015), 57026-5000 (for UL1007)

After clamping the contact (accessory) and the cable, insert the contact properly into the power supply connector housing (accessory).

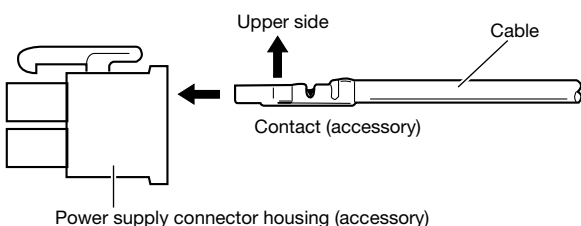

IMPORTANT:

- Conduct the electric conduit work after processing the power supply connector and making sure that the camera is operating normally.

• **Network cable**

Connect a LAN cable (category 5e or better) to the network connector.

IMPORTANT:

- Use all 4 pairs (8 pins) of the LAN cable.
- The maximum cable length is 100 m {328 feet}.
- Make sure that the PoE+ device in use is compliant with IEEE802.3at standard.
- When connecting both of the 24 V AC power supply and the PoE+ device for power supply, 24 V AC will be used for power supply.
- * If a 24 V AC power supply and a PoE+ hub or router are used at the same time, network connections may not be possible. In this case, disable the PoE+ settings. Refer to the operating instructions of the PoE+ hub or router in use.
- * Depending on the PoE+ device used, if you stop the 24 V AC power supply after operating it and a PoE+ hub or router at the same time, the power supply may stop, causing the camera to restart.
- When disconnecting the LAN cable once, reconnect the cable after around 2 seconds. When the cable is quickly connected, the power may not be supplied from the PoE+ device.

• **Output cable for the monitor used for adjustment**

Connect a coaxial cable (BNC) (only for checking if images are displayed on the monitor).

This output is provided only for checking the adjustment of the angular field of view on the video monitor when installing the camera or when servicing.

IMPORTANT:

- The monitor out connector for adjustment is provided only for checking the adjustment of the angular field of view on the monitor used for adjustment when installing the camera or when servicing. It is not provided for recording/monitoring use.
- Black bands may appear at the top and bottom or right and left of the screen. (That does not affect the adjustment because the angular field of view is not changed.)

• External I/O cable

IMPORTANT:

- Off, input, and output of the external I/O terminal 2 and 3 can be switched by configuring the setting. The default of EXT I/O terminal 2 and 3 is "Off". It is possible to determine whether or not to receive input from EXT I/O terminal 2 and 3 (ALARM IN2, 3) by selecting "Off", "Alarm input", "Alarm output" or "AUX output" for "Terminal alarm 2" or "Terminal alarm 3" on the [Alarm] tab on the "Alarm" page. Refer to the Operating Instructions on the provided CD-ROM for further information.
 - When using the EXT I/O terminals as the output terminals, ensure they do not cause signal collision with external signals.
-

<Ratings>

- ALARM IN1/ DAY/NIGHT IN, ALARM IN2, ALARM IN3
Input specification: No-voltage make contact input (4 V - 5 V DC, internally pulled up)
OFF: Open or 4 V - 5 V DC
ON: Make contact with GND (required drive current: 1 mA or more)
- ALARM OUT, AUX OUT
Output specification: Open collector output (maximum applied voltage: 20 V DC)
Open: 4 V - 5 V DC by internal pull-up
Close: Output voltage 1 V DC or less (maximum drive current: 50 mA)

• Microphone/line input cable

Connect a monaural mini plug (ø3.5 mm).

- Input impedance: Approx. 2 k Ω (unbalanced)
- Recommended cable length:
Less than 1 m {3.28 feet} (for microphone input)
Less than 10 m {32.8 feet} (for line input)
- Recommended microphone: Plug-in power type (option)
- Supply voltage: 2.5 V \pm 0.5 V
- Recommended sensitivity of microphone: -48 dB \pm 3 dB (0 dB=1 V/Pa, 1 kHz)
- Input level for the line input: Approx. -10 dBV

• Audio output cable

Connect a stereo mini plug (ø3.5 mm). (Audio output is monaural.) Use an external speaker with amplifier.

- Output impedance: Approx. 600 Ω (unbalanced)
- Recommended cable length: Less than 10 m {32.8 feet}
- Output level: -20 dBV

IMPORTANT:

- Connect/disconnect the audio cables and turn on the power of the camera after turning off the power of the audio output devices. Otherwise, loud noise may be heard from the speaker.
 - Make sure that the stereo mini plug is connected to this cable. When a monaural mini plug is connected, audio may not be heard.
When connecting a monaural speaker with amplifier, use an optional conversion cable (mono-stereo).
-

Connection example

(Refer to page 26 for how to connect the cables.)

When connecting with a PC directly

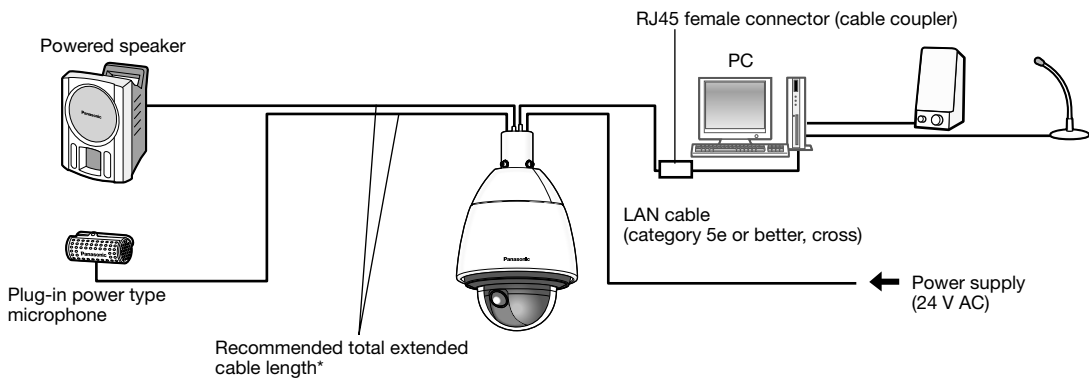

<Required cable>

LAN cable (category 5e or better, cross)

* Recommended cable length from the speaker: less than 10 m {32.8 feet}
Recommended cable length from the microphone: less than 1 m {3.28 feet}

Connecting to a network using a PoE+ hub when the temperature is $-30\text{ }^{\circ}\text{C}$ $\{-22\text{ }^{\circ}\text{F}\}$ or less

* When connecting to a network using a PoE+ hub when the temperature is $-30\text{ }^{\circ}\text{C}$ $\{-22\text{ }^{\circ}\text{F}\}$ or less, use a 24 V AC power supply or a tested PoE injector.

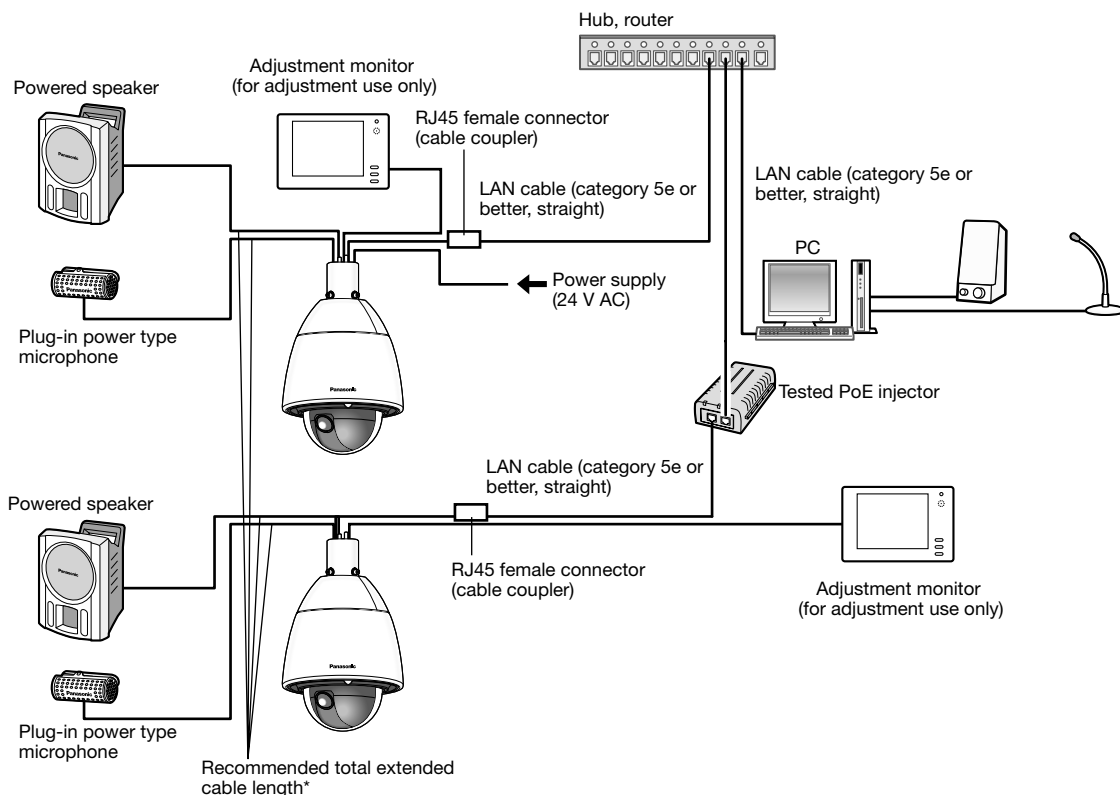

<Required cable>

LAN cable (category 5e or better, straight)

* Recommended cable length from the speaker: less than 10 m {32.8 feet}

Recommended cable length from the microphone: less than 1 m {3.28 feet}

IMPORTANT:

- The adjustment monitor used for adjustment is used for checking the adjustment of the angular field of view when installing the camera or when servicing. It is not provided for recording/monitoring use.
- Depending on the adjustment monitor, some characters (camera title, preset ID, etc.) may not be displayed on the screen.
- Use a switching hub or a router which is compliant with 10BASE-T/100BASE-TX or better. (When supplying the power to a hub or router, apply PoE+ (IEEE802.3at compliant).) It is impossible to supply the power to this product from a PoE hub or router that is compliant with IEEE802.3af standard.
- If a PoE+ hub is not used, each network camera must be connected to a 24 V AC power supply.
- When using 24 V AC, power supply from a PoE+ hub or router is not required.

Configure the network settings

Configuring the camera so that it can be accessed from a PC

The following are descriptions for when the camera with default settings is configured. If you are using firewall software on your PC, the Setup Program may not be able to find any cameras on your network. Configure the setting of the camera after temporarily invalidating the firewall software. Contact the network administrator or your Internet service provider for information about configuring the settings of the network.

1 Insert the provided CD-ROM into the CD-ROM drive of your PC.

- The License Agreement will be displayed. Read the Agreement and choose “I accept the term in the license agreement”, and click [OK].
- The launcher window will be displayed. If the launcher window is not displayed, double click the “CDLauncher.exe” file on the CD-ROM.



Note:

- Refer to “Using the CD-ROM” in the Operating Instructions on the provided CD-ROM for further information about CDLauncher.
-

2 Click the [Run] button next to [IP Setting Software].

[Panasonic IP Setting] screen will be displayed. Click the [Network Settings] button after selecting the MAC address/IP address of the camera to be configured.

3 Select the camera you want to configure, and click [Access Camera].

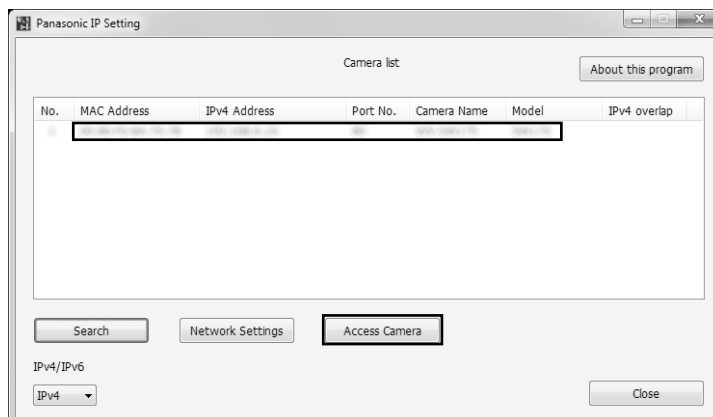

Note:

- When cameras are displayed in [Panasonic IP Setting] screen, click the camera with same MAC address as the MAC address printed on the camera that you want to configure.
-

4 If the installation screen of the viewer software “Network Camera View 4S” is displayed, follow the instructions of the wizard to start the installation. (The viewer software is installed from the camera.)

- The “Live” page will be displayed.
- If you cannot install the viewer software “Network Camera View 4S” or if images are not displayed, click the [Install] button next to [Viewer Software] on the launcher window to install the software.
- Perform the [Time & date] settings in the “Setup” - “Basic” page before using the camera.

Note:

- When no image is displayed on the “Live” page, refer to the Troubleshooting in the Operating Instructions on the provided CD-ROM.
 - It is possible to enhance the network security by encrypting the access to cameras using the HTTPS function. Refer to the Operating instructions on the provided CD-ROM for how to configure the HTTPS settings.
 - Click the [Setup] button on the “Live” page, the user authentication window will be displayed. Enter the default user name and password as follows, and log in.
User name: admin
Password: 12345
 - When changing settings related to the network settings, such as connection mode, IP address, and subnet mask, click the [Network Settings] button in [Panasonic IP Setting] screen as shown in step 3, then change each setting.
 - Due to security enhancements in “IP Setting Software”, “Network settings” of the camera to be configured cannot be changed when around 20 minutes have passed after turning on the power of the camera. (When the effective period is set to “20 min” in the “Easy IP Setup accommodate period”.)
However, settings can be changed after 20 minutes for cameras in the initial set mode.
 - “Network Camera Recorder with Viewer Software Lite” which supports live monitoring and recording images from multiple cameras is available. For further information, refer to our website (<http://security.panasonic.com/pss/security/support/info.html>).
-

Troubleshooting

Before asking for repairs, check the symptoms with the following table.

Contact your dealer if a problem cannot be solved even after checking and trying the solution in the table or a problem is not described below.

| Symptom | Cause/solution | Reference pages |
|---|--|---|
| Power is not turned on. | When using a PoE+ device for power supply <ul style="list-style-type: none"> • Are the PoE+ (IEEE802.3at compliant) device and the RJ-45 female connector (cable coupler) connected using a LAN cable (category 5e or better)? Check whether the connection is appropriately established. • Depending on the PoE+ device, the power supply will stop when the demanded power exceeds its total power limit for all PoE+ ports. Refer to the operating instructions of the PoE+ device in use. • When connecting both of the 24 V AC power supply and the PoE+ device for power supply, the network connection may not be established. Turn down the power supply from the PoE+ device. | 26 – 27 |
| | When using AC power supply <ul style="list-style-type: none"> • Is the power cable connected firmly to power that meets the required specifications? Check whether the connection is appropriately established. • Is the power supply connector housing attached to the camera firmly? Check if it is attached correctly and firmly. | 26 27 |
| The camera does not move to the preset positions accurately. | <ul style="list-style-type: none"> • When the preset positions become inaccurate during use, it is possible to correct the positions by executing the position refresh function. In addition, when "Position refresh" is set for the created schedule, the camera position will be corrected periodically. In some situations, reconfigure the preset positions. | Operating Instructions (included in the CD-ROM) |
| When the camera is panning/tilting, the camera stops panning/tilting and mechanical noise comes from the camera. | <ul style="list-style-type: none"> • The camera position may have become inaccurate. Carry out the refresh position function from the [Default reset] tab of the "Maintenance" page of the setup menu. | Operating Instructions (included in the CD-ROM) |
| The camera starts panning unpredictably. | <ul style="list-style-type: none"> • This may be caused by noise. Check the exogenous noise level around the camera. | 11 |
| When the power is turned on, the live indicator lights or blinks orange. | <ul style="list-style-type: none"> • Is the LAN cable connected appropriately? Connect the LAN cable appropriately. • Is the hub or router connected to the camera operating appropriately? Check if the hub or router in use is operating appropriately. • Isn't the LAN cable connected to the camera broken? Replace the cable with another one. | 27 |

| Symptom | Cause/solution | Reference pages |
|--|--|---|
| Live indicator keeps on blinking orange approx. in 2 seconds intervals. | <ul style="list-style-type: none"> UPnP™ error has occurred since the power is not supplied to the router. Turn on the power of the router. Wait until the connections are established. | - |
| | <ul style="list-style-type: none"> An error has occurred during the port update by the UPnP function. If the router in use does not support the UPnP function, perform the port forwarding setting for the router. In addition, deactivate the setting of auto port forwarding for the camera. | Operating Instructions (included in the CD-ROM) |
| | <ul style="list-style-type: none"> UPnP function of the router is disabled. Refer to the operating instructions of the router to enable the UPnP function. | - |
| Live indicator never lights up. | <ul style="list-style-type: none"> Is "Off" selected for "Link/Access LED" on the "Basic" page? Select "On" or "On(Access)" for the indicator setting. | Operating Instructions (included in the CD-ROM) |
| Live indicator keeps on blinking red. | <ul style="list-style-type: none"> The camera may be out of order. Contact your dealer. Refer to the readme file on the provided CD-ROM for further information after checking the displayed contents of the "Maintenance" page - the [Status] tab - "Self check" of the setup menu. | - |
| Live indicator lights red. | <ul style="list-style-type: none"> Isn't the write protect switch of the inserted SD memory card set to "LOCK"? Unlock the write protect switch of the SD memory card. Hasn't the inserted SD memory card been formatted on a PC? Use an SD memory card formatted on the camera. Or install the software to format the SD memory card on the PC. Refer to our website (http://security.panasonic.com/pss/security/support/info.html) for further information about the supported software. Isn't the inserted SD memory card faulty? Replace the card with a normal one. | Operating Instructions (included in the CD-ROM) |
| Audio input contains noise. | <ul style="list-style-type: none"> Check the following. <ul style="list-style-type: none"> Grounding of the camera, a switching hub or peripheral devices are not done. The camera is used near an electrical power line. The camera is used near a device which produces strong magnetic field or radio waves (such as near a TV/radio antenna, a motor of an air conditioning system, a transformer, etc.) <p>When audio input still contains noise even after checking the above possibilities, use a powered microphone or connect audio output with low output impedance.</p> | 13 |
| The power cable insulation is damaged. | <p>The power cable and connectors are worn out. This may result in electric shock or a fire. Unplug the power cable from the AC outlet immediately, and refer to qualified service personnel.</p> | - |
| The power cable, plug and connectors get hot during use. | | |
| The power cable gets hot when bent or stretched. | | |

| Symptom | Cause/solution | Reference pages |
|---|---|-----------------|
| It is hard to see images with the camera when there are raindrops on the dome cover. | The effectiveness of the rain wash coating may have been reduced. Refer to "Cleaning this product body" in "Precautions for use" and clean the dome cover. If the situation does not improve contact your dealer. | 10 |

About the live indicator

The live indicator will light or blink as follows depending on the camera status.

| Operation status | | Indicator status |
|--|--|---|
| When the power is turned on | Before the network connection is established | Lights orange → Lights off → Blinks orange → Lights orange |
| | When the network connection is established | Lights orange → Lights off → Blinks orange → Blinks green → Lights green |
| During the standby or connection (Cable is not connected.) | | Lights orange |
| During the standby or connection (Cable is connected.) | | Lights green |
| During the upgrade process | | Blinks orange |
| During the initialization | | Lights orange → Lights off → Blinks orange → Lights orange |
| Port forwarding error caused by the UPnP function | | Blinks orange (in 2 seconds intervals (on for 1 second / off for 1 second)) |
| Trouble happening on the camera | | Blinks red |
| Failure in writing data on the SD memory card | | Lights red |

Specifications

• Basic

| | |
|----------------------------------|--|
| Power source *1: | AC 24 V, PoE+ device (IEEE802.3at compliant) or Tested PoE injector (60 W) |
| Power consumption *1: | AC 24 V: 3.5 A/Approx. 55 W Tested Power over Ethernet (Injector: 60 W) DC 54 V: 1.0 A/Approx. 50 W PoE+ DC 54 V: 470 mA/Approx. 25 W (Class4 device) |
| Operating environment | |
| Ambient operating temperature: | -50 °C to +55 °C {-58 °F to +131 °F} (AC 24 V/ Tested PoE injector (60 W)) -30 °C to +55 °C {-22 °F to +131 °F} (PoE+ device) (Power On range: -30 °C to +55 °C {-22 °F to +131 °F}) (AC 24 V/ PoE+ device/ Tested PoE injector (60 W)) |
| Ambient operating humidity: | 10 % to 90 % (no condensation) |
| Storage environment | |
| Storage temperature: | -50 °C to +70 °C {-58 °F to +158 °F} |
| Storage humidity: | 10 % to 95 % (no condensation) |
| Monitor output (for adjustment): | VBS: 1.0 V [p-p]/75 Ω, composite (BNC) An NTSC or PAL monitor can be connected to the camera (the monitor type can be changed by the software). |
| External I/O terminals: | ALARM IN 1 (DAY/NIGHT IN)/ ALARM IN 2 (ALARM OUT)/ ALARM IN 3 (AUX OUT) (x1 each) DAY/NIGHT IN, ALARM OUT, and AUX OUT can be used by changing the settings of Terminal 1, Terminal 2, and Terminal 3. |
| Microphone/line input: | ø3.5 mm monaural mini jack Input impedance: Approx. 2 kΩ (unbalanced) |
| For microphone input: | Applicable microphone: Plug-in power type Supply voltage: 2.5 V ±0.5 V Recommended sensitivity of microphone: -48 dB±3 dB (0 dB=1 V/Pa, 1 kHz) |
| For line input: | Input level: Approx. -10 dBV |
| Audio output: | ø3.5 mm stereo mini jack (monaural output): Output impedance: Approx. 600 Ω (unbalanced) Output level: -20 dBV |
| Water resistance *2: | SW598A Main body: IP66 (IEC60529), Type 4X (UL50), NEMA 4X SW397B Main body: IP66 (IEC60529), Type 4 (UL50), NEMA 4 |
| Shock resistance: | Compliant with IK10 (IEC62262) |
| Dimensions: | Maximum ø229 mm x 392 (H) mm {ø9-1/32 inches x 15-7/16 inches (H)}, |
| Mass: | Approx. 5.0 kg {11.02 lbs} |
| Finish: | Main body: Aluminum die cast Natural silver Sunshields*3: ASA resin coating Natural silver Dome cover section: Polycarbonate resin (Rain wash coating) SW598A Polycarbonate resin SW397B |

*1 Refer to our website (<http://security.panasonic.com/pss/security/support/info.html>) for further information about Power source and Power consumption information.

*2 Only when installation work is properly performed according to the instructions in this book and appropriate waterproof treatment is performed.

*3 It is impossible to remove the main sunshield.

• Camera

| | |
|--------------------------------|---|
| Image sensor: | Approx. 1/3 type MOS image sensor |
| Effective pixels: | Approx. 2.4 megapixels |
| Scanning area: | 5.35 mm (H) × 3.34 mm (V) {7/32 inches (H) × 1/8 inches (V)} |
| Scanning system: | Progressive |
| Minimum illumination: | <p>SW598A</p> <p>Color: 0.15 lx {0.014 foot-candle} (F1.6, Auto slow shutter: Off (1/30 s), AGC: High) 0.009 lx {0.00084 foot-candle} (F1.6, Auto slow shutter: max. 16/30 s, AGC: High)*</p> <p>BW: 0.018 lx {0.00167 foot-candle} (F1.6, Auto slow shutter: Off (1/30 s), AGC: High) 0.001 lx {0.00011 foot-candle} (F1.6, Auto slow shutter: max. 16/30 s, AGC: High)*</p> <hr style="border-top: 1px dashed black;"/> <p>SW397B</p> <p>Color: 0.10 lx {0.0092 foot-candle} (F1.6, Auto slow shutter: Off (1/30 s), AGC: High) 0.007 lx {0.00065 foot-candle} (F1.6, Auto slow shutter: max. 16/30 s, AGC: High)*</p> <p>BW: 0.013 lx {0.00121 foot-candle} (F1.6, Auto slow shutter: Off (1/30 s), AGC: High) 0.001 lx {0.00009 foot-candle} (F1.6, Auto slow shutter: max. 16/30 s, AGC: High)*</p> <p>* Converted value</p> |
| Super-Dynamic: | On/Off |
| Dynamic range: | 52 dB typ. (Super Dynamic: On) |
| Face SD: | On/Off |
| Gain (AGC): | On (High)/ On (Mid)/ On (Low)/ Off |
| Adaptive black stretch: | On/Off |
| Back light compensation (BLC): | On/Off (Super Dynamic: Off) |
| Fog compensation: | On/Off (Super Dynamic and Adaptive black stretch: Off) |
| Light control mode setting: | Outdoor scene/ Indoor scene (50 Hz)/ Indoor scene (60 Hz)/ Fix shutter |
| Shutter speed: | Off (1/30), 3/100, 3/120, 2/100, 2/120, 1/100, 1/120, 1/250, 1/500, 1/1000, 1/2000, 1/4000, 1/10000 |
| Auto slow shutter: | Off (1/30 s), max. 2/30 s, max. 4/30 s, max. 6/30 s, max. 10/30 s, max. 16/30 s |
| Color/BW: | On/ Off/ AUTO1/ AUTO2/ AUTO3 |
| White balance: | ATW1/ ATW2/ AWC |
| Digital noise reduction: | High/Low |
| Image stabilizer: | On/Off |
| Privacy zone: | Gray/Mosaic/Off (up to 32 zones available) |
| Camera title on screen: | On/Off Up to 20 characters (alphanumeric characters, marks) Character size: Large/ Middle/ Small |
| Video Motion Detection (VMD): | On/Off, 4 areas available |
| Image hold: | On/Off |

• Lens

| | |
|----------------------------|---|
| Zoom ratio: | 30x 45x with HD Extra Optical Zoom (Resolution 1280x720) SW397B 90x with Extra Optical Zoom (Resolution 640x360) SW598A |
| Digital (electronic) zoom: | 12x (Max 1080x combined with Extra Optical Zoom: Resolution 640x360) |
| Focal length: | 4.3 mm - 129.0 mm {3/16 inches - 5-3/32 inches} |
| Maximum aperture ratio: | 1:1.6 (WIDE) - 4.7 (TELE) |
| Focus range: | 2.0 m - ∞ |
| Aperture range: | F1.6 (WIDE) - Close |
| Angular field of view: | [16:9 mode] Horizontal: 2.6 ° (TELE) - 63 ° (WIDE) Vertical: 1.5 ° (TELE) - 37 ° (WIDE) [4:3 mode] Horizontal: 1.9 ° (TELE) - 46 ° (WIDE) Vertical: 1.5 ° (TELE) - 37 ° (WIDE) |

• Panning/tilting platform

| | |
|---------------------------------|---|
| Panning range: | 360 ° Endless panning |
| Panning speed: | Manual: Approx. 0.065 °/s - 120 °/s, Preset: Up to approx. 300 °/s |
| Tilting range: | Operational range: -15 ° - 195 ° (level – downward – level) Recommended range*1: 0 ° - 180 ° Selectable tilting angle: 10 ° / 5 ° / 3 ° / 0 °*2 / -3 °*2 / -5 °*2 / -10 °*2 / -15 °*2 |
| Tilting speed: | Manual: Approx. 0.065 °/s - 120 °/s, Preset: Up to approx. 300 °/s |
| Number of the preset positions: | 256 |
| Auto mode: | Auto track/ Auto pan/ Preset sequence/ 360 map-shot/ Patrol |
| Self return: | 10 s/ 20 s/ 30 s/ 1 min/ 2 min/ 3 min/ 5 min/ 10 min/ 20 min/ 30 min/ 60 min |
| Map shot: | 360 map-shot/Preset map-shot |

*1 The recommended range is a guide for the range of angles at which images can be completely viewed. If the camera is tilted to an angle higher than in this range, parts of the image may not be able to be viewed.

*2 If "0 °", "-3 °", "-5 °", "-10 °", or "-15 °" is selected, the area hidden by the camera housing may increase when the tilt angle of the camera is almost level. When "-15 °" is selected for "Tilt Angle", the upper half of images will be hidden.

• Network

| | |
|---------------------------|---|
| Network: | 10BASE-T/100BASE-TX, RJ45 connector |
| Resolution: SW598A | <ul style="list-style-type: none"> When "2 mega pixel [16:9]" is selected for "Image capture mode" <ul style="list-style-type: none"> H.264 1920x1080/640x360/320x180, max. 30 fps JPEG (MJPEG) 1920x1080/640x360/320x180, max. 30 fps When "1.3 mega pixel [16:9]" is selected for "Image capture mode" <ul style="list-style-type: none"> H.264 1280x720/640x360/320x180, max. 30 fps JPEG (MJPEG) 1280x720/640x360/320x180, max. 30 fps When "1.3 mega pixel [4:3]" is selected for "Image capture mode" <ul style="list-style-type: none"> H.264 1280x960/VGA/QVGA, max. 30 fps JPEG (MJPEG) 1280x960/VGA/QVGA, max. 30 fps |
| SW397B | <ul style="list-style-type: none"> When "16:9" is selected for "Aspect ratio" <ul style="list-style-type: none"> H.264 1280x720/640x360/320x180, max. 30 fps JPEG (MJPEG) 1280x720/640x360/320x180, max. 30 fps When "4:3" is selected for "Aspect ratio" <ul style="list-style-type: none"> H.264 1280x960/800x600/VGA/QVGA, max. 30 fps JPEG (MJPEG) 1280x960/800x600/VGA/QVGA, max. 30 fps |

| | |
|---|---|
| Image compression method: H.264*1 | Image quality: Low/ Normal/ Fine Transmission type: Unicast/Multicast Video bit rate: (Constant bit rate/VBR/Best effort/Advanced VBR) 64 kbps/ 128 kbps/ 256 kbps/ 384 kbps/ 512 kbps/ 768 kbps/ 1024 kbps/ 1536 kbps/ 2048 kbps/ 3072 kbps/ 4096 kbps/ 6144 kbps/ 8192 kbps/ 10240 kbps/ 12288 kbps/ 14336 kbps (Frame rate) 1 fps/ 3 fps/ 5 fps/ 7.5 fps/ 10 fps/ 12 fps/ 15 fps/ 20 fps/ 30 fps JPEG (MJPEG) |
| JPEG (MJPEG) | Image quality: 0 SUPER FINE/ 1 FINE/ 2/ 3/ 4/ 5 NORMAL/ 6/ 7/ 8/ 9 LOW (10 steps: 0-9) Transmission type: PULL/ PUSH Transmission interval: 0.1 fps - 30 fps (JPEG frame rate will be restricted when displaying both JPEG and H.264 images.) |
| Audio compression method: | G.726 (ADPCM) 32 kbps/ 16 kbps, G.711 64 kbps, AAC-LC*2 |
| Bandwidth control: | Unlimited/ 64 kbps/ 128 kbps/ 256 kbps/ 384 kbps/ 512 kbps/ 768 kbps/ 1024 kbps/ 2048 kbps/ 4096 kbps/ 8192 kbps |
| Protocol: | IPv6: TCP/IP, UDP/IP, HTTP, HTTPS, FTP, SMTP, DNS, NTP, SNMP, DHCPv6, RTP, MLD, ICMP, ARP IPv4: TCP/IP, UDP/IP, HTTP, HTTPS, RTSP, RTP, RTP/RTCP, FTP, SMTP, DHCP, DNS, DDNS, NTP, SNMP, UPnP, IGMP, ICMP, ARP |
| OS*3: | Microsoft Windows 8.1 Microsoft Windows 8 Microsoft Windows 7 Microsoft Windows Vista |
| Browser: | Windows Internet Explorer 11 (32-bit) Windows Internet Explorer 10 (32-bit) Windows Internet Explorer 9 (32-bit) Windows Internet Explorer 8 (32-bit) Windows Internet Explorer 7 (32-bit) |
| Maximum concurrent access number: | 14 (Number of sessions that can connect to cameras at the same time) * Depends on network conditions |
| FTP client: | Alarm image transmission, FTP periodic transmission (When the FTP transmission is failed, backup on an optional SD memory card is available.) |
| Multi-screen: | Up to 16 camera images can be displayed simultaneously on a multi-screen. (Including the camera itself) |
| Compatible SDXC/SDHC/ SD memory card*4*5: | Manufactured by Panasonic (SD speed class 4 or higher) SDXC memory card: 64 GB, 128 GB SDHC memory card: 4 GB, 8 GB, 16 GB, 32 GB SD memory card: 2 GB (except miniSD card and microSD card) |
| Cellular phone compatibility: | JPEG image, panning/tilting/zoom/focus control, AUX control (by access level) |
| Mobile terminal compatibility: (As of October, 2015)*6 | iPad, iPhone, iPod touch (iOS 4.2.1 or later) Android™ mobile terminals |

*1 Transmission for 2 streams can be individually set.

*2 AAC-LC (Advanced Audio Coding - Low Complexity) is only used when recording audio on an SD memory card.

*3 For further information about PC system requirements and precautions for when using Microsoft Windows 8.1, Microsoft Windows 8, Microsoft Windows 7, Microsoft Windows Vista, or Windows Internet Explorer, click "Manual" - "Open" from the supplied CD-ROM and refer to "Notes on Windows® / Internet Explorer® versions".

*4 Refer to our website (<http://security.panasonic.com/pss/security/support/info.html>) for latest information about the compatible SD memory cards.

*5 When repeatedly recording images on an SD memory card using the auto overwrite function, make sure to use an SD memory card with high reliability and durability.

*6 For further information about compatible devices, refer to our website (<http://security.panasonic.com/pss/security/support/info.html>).

Standard accessories

| | |
|--|-------|
| Installation Guide (this document) | 1 pc. |
| Warranty card | 1 pc. |
| CD-ROM*1 | 1 pc. |
| Code label*2 | 1 pc. |

The following parts are used during installation procedures.

| | |
|--|------------------------|
| Front and rear sunshields | 1 pc. each |
| Front/rear sunshield fixing screw | 2 pcs. (incl. 1 spare) |
| 8P alarm cable | 1 pc. |
| 24 V AC power supply connector kit..... | 1 pc. |
| (Power supply connector housing: 1 pc., Contact: 3 pcs.) | |
| Protection Cover*3 | 1 pc. |
| Cable coupler (used with the network cable)..... | 1 pc. |

*1 The CD-ROM contains the operating instructions and different kinds of tool software programs.

*2 This label may be required for network management. The network administrator shall retain the code label.

*3 The Protection Cover is used when sending the camera for repairs, and when moving or transporting the camera. Keep it for future use.

Optional accessories

| | |
|------------------------------------|-----------------------|
| Ceiling Mount Bracket | WV-Q121B |
| Wall Mount Bracket | WV-Q122A |
| User License Accessory (For H.264) | BB-HCA8A BB-HCA8CE |

Disposal of Old Equipment and Batteries

Only for European Union and countries with recycling systems



These symbols on the products, packaging, and/or accompanying documents mean that used electrical and electronic products and batteries must not be mixed with general household waste. For proper treatment, recovery and recycling of old products and used batteries, please take them to applicable collection points in accordance with your national legislation.

By disposing of them correctly, you will help to save valuable resources and prevent any potential negative effects on human health and the environment.

For more information about collection and recycling, please contact your local municipality.

Penalties may be applicable for incorrect disposal of this waste, in accordance with national legislation.



Note for the battery symbol (bottom symbol)

This symbol might be used in combination with a chemical symbol. In this case it complies with the requirement set by the Directive for the chemical involved.

For U.S. and Canada:

**Panasonic System Communications
Company of North America,
Unit of Panasonic Corporation of North America**
www.panasonic.com/business/
For customer support, call 1.800.528.6747
Two Riverfront Plaza, Newark, NJ 07102-5490

Panasonic Canada Inc.
5770 Ambler Drive, Mississauga, Ontario, L4W 2T3 Canada
(905)624-5010
www.panasonic.ca

For Europe and other countries:

Panasonic Corporation
<http://www.panasonic.com>

Panasonic System Networks Co., Ltd.
Fukuoka, Japan

Authorised Representative in EU:



Panasonic Testing Centre
Panasonic Marketing Europe GmbH
Winsbergring 15, 22525 Hamburg, Germany