

REVISION HISTORY				
ZONE	REV	DESCRIPTION	DATE	APPROVED
All	9	Re-Designed Cover and Base	10/18/2016	RLC

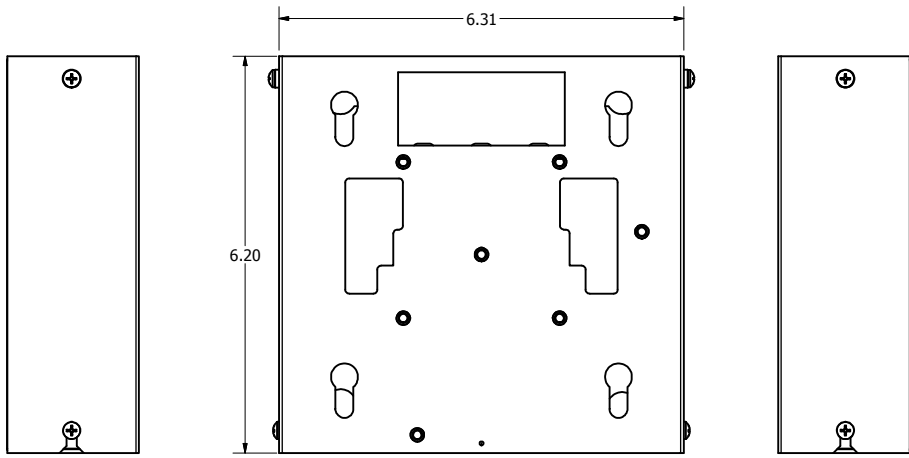

FRONT VIEW

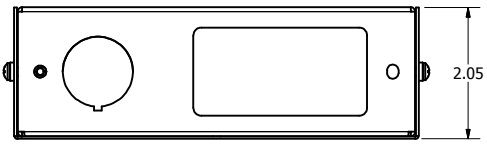
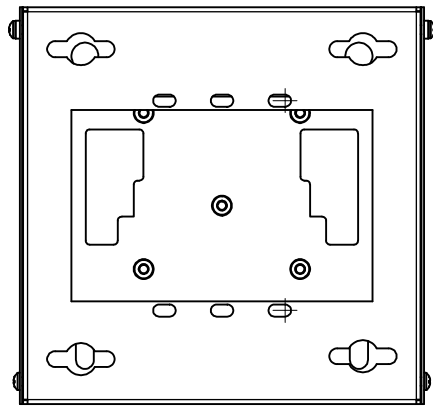

BACK VIEW

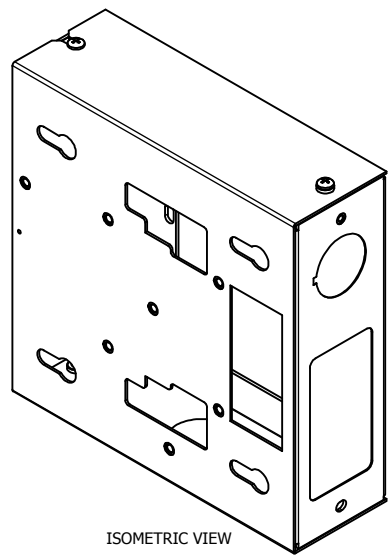

ISOMETRIC VIEW

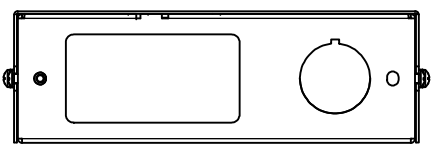

NOTE:
 -Material: Cover: 20 Gauge Steel
 Base: 16 Gauge Steel
 -Finish: White Powder Coat

NOTE: All materials used in the construction of Oberon products must be RoHS compliant and meet RoHS2 Directive 2011/65/EU. Contact Oberon engineering if RoHS compliant materials are not available.

DRAWN	RLC	3/2/2016	Oberon, Inc. - 1315 S. Allen St. - State College, PA 16801	
CHECKED	RLC	1/15/2016	TITLE	
QA			Model 900-00	
MFG	RLC	1/15/2016	SIZE	DWG NO
APPROVED	RLC	1/15/2016	C	2555
TOLERANCE:	.0 = +/- .030		SCALE	SHEET 1 OF 1
	.00 = +/- .015			
	.000 = +/- .005			