

# Tsunami® GX-824

## Carrier Grade 24 GHz Unlicensed Microwave Backhaul

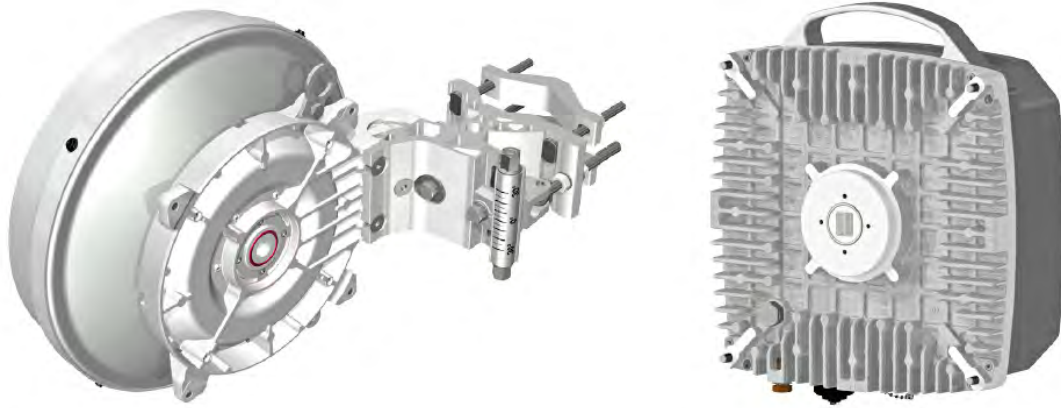

### Point-to-Point (PtP) unlicensed microwave product operating in the 24 GHz band.

Proxim Wireless is a leader and an early innovator in wireless technology providing high-speed, long-range and mobile broadband wireless solutions.

Tsunami® GX-824, is a very high throughput, extremely reliable and cost-effective, all outdoor unlicensed point-to-point (PtP) microwave solution operating in the 24 GHz band. With its capacity up to 900 Mbps full duplex (1.8 Gbps aggregate), hitless ACM and modulation schemes up to 1024QAM, Tsunami® GX-824 brings new dimension to microwave links market and can be used as adequate alternative to 60 and 80 GHz millimeter wave links.

### Features

- 24 GHz Unlicensed Frequency bands
- 3.5 to 112 MHz channels
- Transmission capacity up to 900 Mbps
- 1.8 Gbps for 2+0 configuration
- Two Gigabit Ethernet + one SM/MM fiber interfaces
- Jumbo packets up to 10,240 Bytes
- Modulation type QPSK to 1024 QAM
- Hitless adaptive coding & modulation
- Forward error correction (FEC)
- Automatic TX power control (ATPC)
- All-Outdoor design with 1, 2, 3 or 4 foot antennas (30, 60, 90 or 120 cm)
- Full overvoltage protection of ODU unit

### Applications

- Local / Metropolitan / Wide area networks
- IPTV distribution
- Multimedia applications
- Last miles

### Management

- Proprietary GX-824 Manager
- Software configurable
- Independent diagnostic channel
- SNMP protocol
- WEB interface
- Command line interface
- System configuration 1+0, 1+1 or 2+0

### Ethernet

- QoS support (VLAN p-bit / DSCP / port priority)
- Full support of VLAN and QinQ (802.1Q,802.1ad)
- Two independent Ethernet lines through radio link
- Ethernet port shutdown when the radio link is bad

### Ethernet

- Full over voltage protection
- DIN rail or rack mount compatible
- Compact 1U rack unit for 3 injectors
- GX-824-POEINJ surge protected PoE injector and GX-824-PSU-ACDC 48 VDC power supply are not included in with link (to be ordered separately)

PRODUCT MODELS		PART NUMBER
GX-824-SM-LNK-A30	Tsunami GX-824 Link, 920 Mbps FD, Gigabit Eth + SM Fiber, 1 ft – 30 cm antenna	952-00315
GX-824-MM-LNK-A30	Tsunami GX-824 Link, 920 Mbps FD, Gigabit Eth + MM Fiber, 1 ft – 30 cm antenna	952-00316
GX-824-SM-LNK-A60	Tsunami GX-824 Link, 920 Mbps FD, Gigabit Eth + SM Fiber, 2 ft – 60 cm antenna	952-00317
GX-824-MM-LNK-A60	Tsunami GX-824 Link, 920 Mbps FD, Gigabit Eth + MM Fiber, 2 ft – 60 cm antenna	952-00318
GX-824-SM-LNK-A90	Tsunami GX-824 Link, 920 Mbps FD, Gigabit Eth + SM Fiber, 3 ft – 90 cm antenna	952-00319
GX-824-MM-LNK-A90	Tsunami GX-824 Link, 920 Mbps FD, Gigabit Eth + MM Fiber, 3 ft – 90 cm antenna	952-00320
GX-824-SM-LNK-A120	Tsunami GX-824 Link, 920 Mbps FD, Gigabit Eth + SM Fiber, 4 ft – 120 cm antenna	952-00321
GX-824-MM-LNK-A120	Tsunami GX-824 Link, 920 Mbps FD, Gigabit Eth + MM Fiber, 4 ft – 120 cm antenna	952-00322

INTERFACES	
ETHERNET	Two Gigabit Ethernet 1000Base-T (RJ45) Auto MDIX ports with 10k jumbo frame support One Optic Fiber 1000Base-SX / 1000Base-LX / 1000Base-BX port
MANAGEMENT	Diagnostic channel with Ethernet / RS-232 interface Antenna alignment voltage (BNC)
ANTENNA	Integrated with the ODU

RADIO & TRANSMISSION																																																																																	
MODULATION	QPSK, 8PSK, 16QAM, 32QAM, 64QAM, 128QAM, 256QAM, 1024QAM with Hitless adaptive coding & modulation (ACM)																																																																																
FREQUENCY BANDS	Frequency Range 24.000 to 24.250GHz																																																																																
CHANNEL BANDWIDTH	Wideband support. Configurable from 3.5 to 112 MHz																																																																																
TX POWER	From -27 to +5 dBm																																																																																
TX POWER CONTROL	Automatic Transmit Power Control (ATPC)																																																																																
RX SENSITIVITY	<table border="1"> <thead> <tr> <th>Channel Size (MHz)</th> <th>3.5 MHz</th> <th>7 MHz</th> <th>14 MHz</th> <th>28 MHz</th> <th>56 MHz</th> <th>80 MHz</th> <th>112 MHz</th> </tr> </thead> <tbody> <tr> <td>QPSK</td> <td>-94</td> <td>-91</td> <td>-88</td> <td>-85</td> <td>-83</td> <td>-81</td> <td>-79</td> </tr> <tr> <td>8PSK</td> <td>-91</td> <td>-88</td> <td>-85</td> <td>-81</td> <td>-79</td> <td>-77</td> <td>-75</td> </tr> <tr> <td>16QAM</td> <td>-88</td> <td>-85</td> <td>-82</td> <td>-78</td> <td>-76</td> <td>-75</td> <td>-73</td> </tr> <tr> <td>32QAM</td> <td>-84</td> <td>-82</td> <td>-79</td> <td>-75</td> <td>-73</td> <td>-71</td> <td>-69</td> </tr> <tr> <td>64QAM</td> <td>-81</td> <td>-79</td> <td>-76</td> <td>-72</td> <td>-70</td> <td>-68</td> <td>-66</td> </tr> <tr> <td>128QAM</td> <td>-78</td> <td>-76</td> <td>-73</td> <td>-69</td> <td>-67</td> <td>-65</td> <td>-63</td> </tr> <tr> <td>256QAM</td> <td>-75</td> <td>-73</td> <td>-70</td> <td>-66</td> <td>-64</td> <td>-62</td> <td>-60</td> </tr> <tr> <td>512QAM</td> <td>-71</td> <td>-70</td> <td>-67</td> <td>-64</td> <td>-60</td> <td>-58</td> <td>-56</td> </tr> <tr> <td>1024QAM</td> <td>-68</td> <td>-65</td> <td>-63</td> <td>-60</td> <td>-57</td> <td>-54</td> <td>-52</td> </tr> </tbody> </table>	Channel Size (MHz)	3.5 MHz	7 MHz	14 MHz	28 MHz	56 MHz	80 MHz	112 MHz	QPSK	-94	-91	-88	-85	-83	-81	-79	8PSK	-91	-88	-85	-81	-79	-77	-75	16QAM	-88	-85	-82	-78	-76	-75	-73	32QAM	-84	-82	-79	-75	-73	-71	-69	64QAM	-81	-79	-76	-72	-70	-68	-66	128QAM	-78	-76	-73	-69	-67	-65	-63	256QAM	-75	-73	-70	-66	-64	-62	-60	512QAM	-71	-70	-67	-64	-60	-58	-56	1024QAM	-68	-65	-63	-60	-57	-54	-52
Channel Size (MHz)	3.5 MHz	7 MHz	14 MHz	28 MHz	56 MHz	80 MHz	112 MHz																																																																										
QPSK	-94	-91	-88	-85	-83	-81	-79																																																																										
8PSK	-91	-88	-85	-81	-79	-77	-75																																																																										
16QAM	-88	-85	-82	-78	-76	-75	-73																																																																										
32QAM	-84	-82	-79	-75	-73	-71	-69																																																																										
64QAM	-81	-79	-76	-72	-70	-68	-66																																																																										
128QAM	-78	-76	-73	-69	-67	-65	-63																																																																										
256QAM	-75	-73	-70	-66	-64	-62	-60																																																																										
512QAM	-71	-70	-67	-64	-60	-58	-56																																																																										
1024QAM	-68	-65	-63	-60	-57	-54	-52																																																																										
ERROR CORRECTION	Reed-Solomon FEC and Convolutional Interleaver																																																																																
FREQUENCY STABILITY	<10 ppm																																																																																

ANTENNAS OPTION	Dual Polarity Antennas
	1 foot – 30 centimeters, 35.5 dBi
	2 foot – 60 centimeters, 41 dBi
	3 foot – 90 centimeters, 44 dBi
	4 foot – 120 centimeters, 46 dBi

MANAGEMENT	
LOCAL	RS-232 interface
REMOTE	Proprietary GX-824 Manager, telnet (CLI)
SNMP	SNMP v1, Enterprise MIB
OTHER	Spectrum Analyzer

SECURITY	
ENCRYPTION	AES 256 bits

NETWORK	
MODES	1+0, 1+1 SD/FD (protected) or 2+0 (true aggregate)
CONFIGURATION SCHEME	1+0, 1+1 SD/FD (protected) or 2+0 (true aggregate)
THROUGHPUT CAPACITY	900 Mbps full duplex (1800 Mbps true aggregate)
LATENCY	<90 μs @ 900 Mbps
QOS	4 queues based on physical port, 802.1p tag or IP DiffServ
VLAN	802.1Q (4096 VLAN IDs) and QinQ

POWER	
POWER INPUT	48 VDC (support from 36 to 72 VDC)
MAX POWER CONSUMPTION	Up to 27 W

ENVIRONMENTAL SPECS	
OPERATING TEMPERATURE	31 to +131 °F (-35 to +55°C)
RELATIVE HUMIDITY	100%
IP RATING, WIND LOADING	IP65, 70 Mph (112 km/h) Operational, 125 Mph (200 km/h) Survival

PHYSICAL SPECS	
DIMENSIONS	5.2 x 10 x 11.8 in. (133 x 255 x 301 mm)
WEIGHT	11.2 lbs (5.1 kg) without antenna

PACKAGE CONTENTS	
	<ul style="list-style-type: none"> <li>Two Tsunami® GX-824 ODU</li> <li>Two antennas</li> <li>Two Mounting Kits</li> <li>One Quick Installation Guide</li> </ul>

OPTIONS		PART NUMBER
GX-824-PSU-ACDC	110 – 220 VAC to -48 VDC Power Supply Unit for GX-824	949-00130
GX-824-POEINJ	Surge Protected PoE injector (-48 VDC input) for GX-824	949-00131
GX-824-CAP-SM	SM Fiber weatherproofing cap for GX-824	949-00136
GX-824-CAP-MM	MM Fiber weatherproofing cap for GX-824	949-00137

WARRANTY	
	2 year parts and labor. ServPak Extended Support available