

THIS COPY IS PROVIDED ON A RESTRICTED BASIS AND IS NOT TO BE USED IN ANY WAY DETRIMENTAL TO THE INTERESTS OF PANDUIT CORP.

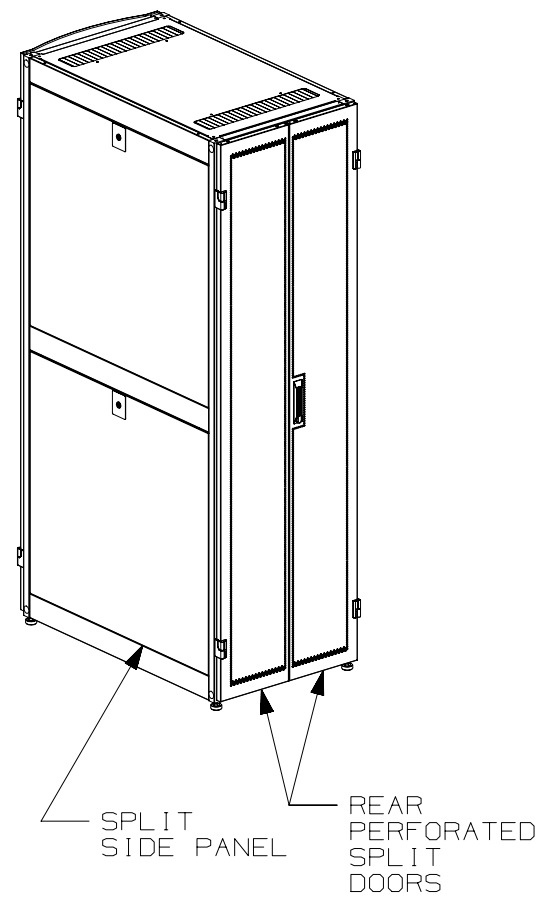
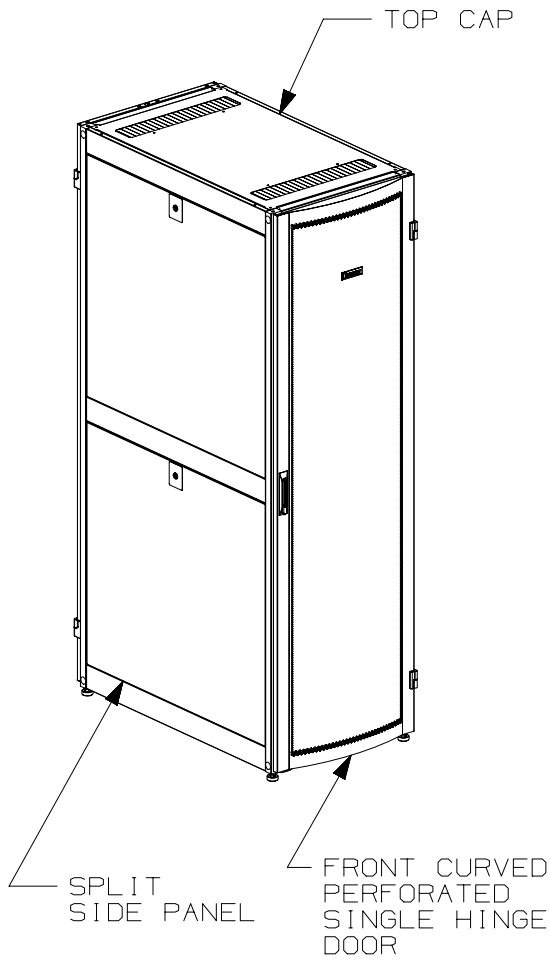

- VISIT OUR ON-LINE CATALOG AT WWW.PANDUIT.COM FOR A LIST OF CURRENT PARTS APPLICABLE FOR USE WITH THIS PRODUCT.
- PRIMARY DIMENSIONS ARE IN MILLIMETERS.
- EQUIPMENT RAILS (E-RAILS) ARE SET TO 738mm [29.1"] FROM THE FACTORY. E-RAILS ARE INFINITELY ADJUSTABLE, FROM A MINIMUM OF 128mm APART, TO A MAXIMUM FOUND IN THE CHART ON SHEET 2.
- CAN BE USED WITH ANY 19" EIA STANDARD COMPONENT IN ADDITION TO ALL PANDUIT HORIZONTAL CABLE MANAGEMENT AND PATCH PANEL PRODUCTS.
- EIA UNIVERSAL STANDARD HOLE PROGRESSION ON EQUIPMENT RAILS
- PARTS SUPPLIED:
 - BASE CABINET
 - FRONT CURVED PERFORATED SINGLE HINGE DOOR, 69% OPEN AREA, OPENS UP TO 165° WHEN GANGED
 - REAR PERFORATED SPLIT DOOR, 69% OPEN AREA, OPENS UP TO 150° WHEN GANGED
 - EQUIPMENT RAILS FRONT & REAR (E-RAILS) (SEE CHART ON SHEET 2)
 - PDU MOUNTING / CABLE MANAGEMENT BRACKETS (CMB)
 - SWIVEL CASTERS
 - LEVELING LEGS
 - INSTRUCTION SHEET
- RACK UNIT SPACING NUMERALS ARE PRINTED ON EQUIPMENT MOUNTING RAILS, NUMBERS UP
- FULLY BONDED STRUCTURE WHEN ASSEMBLED PER INSTRUCTIONS.
- STATIC LOAD RATING 1360 Kg (3000 LBS)
- ROLLING LOAD RATING 500 Kg (1102 LBS)

B

B

A

A

TITLE NET-VERSE D-TYPE CABINET 600 WIDE X 42/45 RU X 1000mm/1200mm DEEP (DN6***B) CUSTOMER DRAWING	
ITEM REVISION NAME 00083FAA/00	
DATASET FILE NAME 00083FAA_DC_00A	
MATERIAL: N/A	
DRAWING NUMBER: 00083FAA-DC	
THIRD ANGLE PROJECTION	
DRAWN BY LEE	DATE 11-16-16
CHK MCIS	SCALE NONE
SHT 1 OF 6	
SIZE A	

00A	11-16-16	LEE	MCIS	RELEASED TO PRODUCTION	V09001BI/03	
REV	DATE	BY	CHK	APR	DESCRIPTION	ECN

D10100DA/16

THIS COPY IS PROVIDED ON A RESTRICTED BASIS AND IS NOT TO BE USED IN ANY WAY DETRIMENTAL TO THE INTERESTS OF PANDUIT CORP.

PART NO.	DESCRIPTION	FRAME HEIGHT	FRAME DEPTH	E-RAIL MAXIMUM SPACING	SIDE PANELS	CABINET UNPACKAGED WEIGHT	CABINET SHIPPING WEIGHT
DN6219B	NET-VERSE D-TYPE CABINET 600mm WIDE X 42RU X 1000mm DEEP	2000.5 (78.76)	1000.0 (39.37)	738 (29.1) WITH CMB 871 (34.3) WITHOUT CMB	00	82 Kg/EACH 180 LBS/EACH	113 Kg/EACH 249 LBS/EACH
DN6212B	NET-VERSE D-TYPE CABINET 600mm WIDE X 42RU X 1000mm DEEP	2000.5 (78.76)	1000.0 (39.37)	738 (29.1) WITH CMB 871 (34.3) WITHOUT CMB	02	121 Kg/EACH 266 LBS/EACH	150 Kg/EACH 331 LBS/EACH
DN6229B	NET-VERSE D-TYPE CABINET 600mm WIDE X 42RU X 1200mm DEEP	2000.5 (78.76)	1200.0 (47.24)	938 (36.9) WITH CMB 1071 (42.2) WITHOUT CMB	00	86 Kg/EACH 190 LBS/EACH	116 Kg/EACH 256 LBS/EACH
DN6222B	NET-VERSE D-TYPE CABINET 600mm WIDE X 42RU X 1200mm DEEP	2000.5 (78.76)	1200.0 (47.24)	938 (36.9) WITH CMB 1071 (42.2) WITHOUT CMB	02	131 Kg/EACH 289 LBS/EACH	164 Kg/EACH 362 LBS/EACH
DN6519B	NET-VERSE D-TYPE CABINET 600mm WIDE X 45RU X 1000mm DEEP	2134.5 (84.04)	1000.0 (39.37)	738 (29.1) WITH CMB 871 (34.3) WITHOUT CMB	00	85 Kg/EACH 188 LBS/EACH	114 Kg/EACH 251 LBS/EACH
DN6512B	NET-VERSE D-TYPE CABINET 600mm WIDE X 45RU X 1000mm DEEP	2134.5 (84.04)	1000.0 (39.37)	738 (29.1) WITH CMB 871 (34.3) WITHOUT CMB	02	125 Kg/EACH 275 LBS/EACH	156 Kg/EACH 344 LBS/EACH
DN6529B	NET-VERSE D-TYPE CABINET 600mm WIDE X 45RU X 1200mm DEEP	2134.5 (84.04)	1200.0 (47.24)	938 (36.9) WITH CMB 1071 (42.2) WITHOUT CMB	00	89 Kg/EACH 196 LBS/EACH	125 Kg/EACH 276 LBS/EACH
DN6522B	NET-VERSE D-TYPE CABINET 600mm WIDE X 45RU X 1200mm DEEP	2134.5 (84.04)	1200.0 (47.24)	938 (36.9) WITH CMB 1071 (42.2) WITHOUT CMB	02	135 Kg/EACH 297 LBS/EACH	175 Kg/EACH 386 LBS/EACH

REV	DATE	BY	CHK	APR	DESCRIPTION	ECN	DRAWN BY	DATE	CHK	SCALE	DRAWING NUMBER	SIZE
00A	11-16-16	LEE	MCIS		SEE SHEET ONE FOR REVISIONS	V09001BI/03	LEE	11-16-16	MCIS	NONE	SHT 2 OF 6	A

TITLE
NET-VERSE D-TYPE CABINET
600 WIDE X 42/45 RU X 1000mm/1200mm DEEP
(DN6***B)
CUSTOMER DRAWING

ITEM REVISION NAME
00083FAA/00

DATASET FILE NAME
00083FAA_DC_00A

MATERIAL:
N/A

DRAWING NUMBER:
00083FAA-DC

THIRD ANGLE PROJECTION

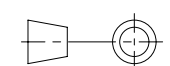

D110100DA/16

THIS COPY IS PROVIDED ON A RESTRICTED BASIS AND IS NOT TO BE USED IN ANY WAY DETRIMENTAL TO THE INTERESTS OF PANDUIT CORP.

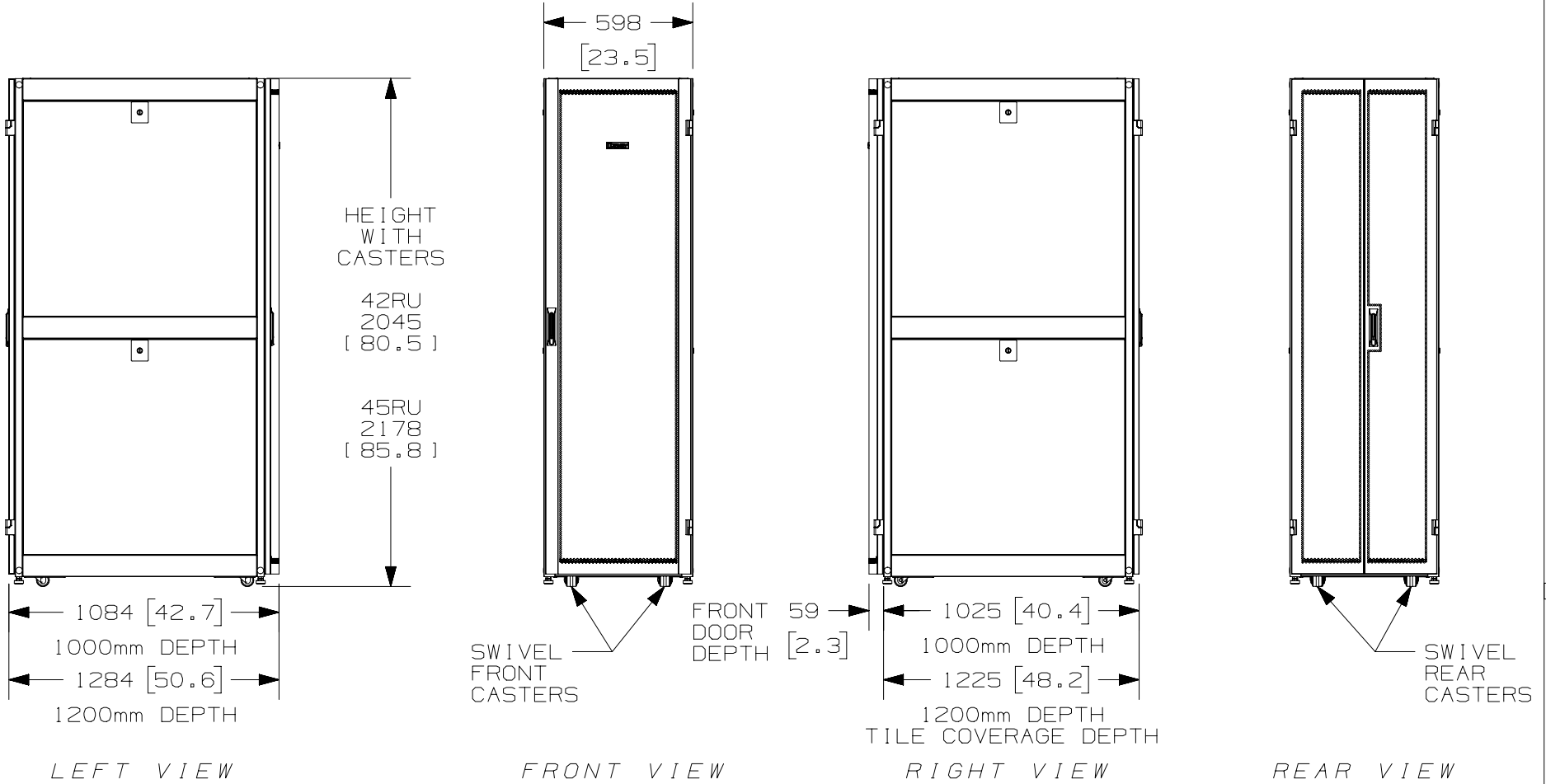

00A	11-16-16	LEE	MCIS		SEE SHEET ONE FOR REVISIONS			V09001BI/03	
REV	DATE	BY	CHK	APR	DESCRIPTION			ECN	

TITLE NET-VERSE D-TYPE CABINET 600 WIDE X 42/45 RU X 1000mm/1200mm DEEP (DN6***B) CUSTOMER DRAWING	
ITEM REVISION NAME 00083FAA/00	
DATASET FILE NAME 00083FAA_DC_00A	
MATERIAL: N/A	
DRAWING NUMBER: 00083FAA-DC	
THIRD ANGLE PROJECTION symbol	THIRD ANGLE PROJECTION
DRAWN BY: LEE	DATE: 11-16-16
CHK: MCIS	SCALE: NONE
	DRAWING NUMBER: SHT 3 OF 6
	SIZE: A

D110100DA/16

2

1

RACK UNITS ARE
NUMBERED AND
INDEXED FOR
IDENTIFICATION

(2)
ADJUSTABLE
FRONT
EQUIPMENT
RAILS

SEE TABLE ON
SHEET 2 FOR
REAR EQUIPMENT
RAIL ADJUSTMENT
RANGE

(2) ADJUSTABLE
REAR EQUIPMENT
RAILS

(2) PDU /
CABLE
MANAGEMENT
BRACKETS

(4) LOCATIONS
TAPPED FOR M12
THREADED ROD
(1) AT TOP OF
EACH VERTICAL
POST

REAR

(2) CABLE
OPENINGS
84mm (3.3") X
476mm (18.7")
WITH BRUSH SEAL

FRONT

TOP VIEW

FRONT

REAR

FRONT DOOR, REAR DOOR,
AND SIDE PANELS NOT SHOWN



A

A

TITLE
NET-VERSE D-TYPE CABINET
600 WIDE X 42/45 RU X 1000mm/1200mm DEEP
(DN6***B)
CUSTOMER DRAWING

ITEM REVISION NAME
00083FAA/00

DATASET FILE NAME
00083FAA_DC_00A

PANDUIT

MATERIAL:
N/A

DRAWING NUMBER:
00083FAA-DC

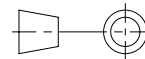

THIRD ANGLE
PROJECTION

00A	11-16-16	LEE	MCIS		SEE SHEET ONE FOR REVISIONS		V09001BI/03		
REV	DATE	BY	CHK	APR	DESCRIPTION		ECN		

DRAWN BY LEE	DATE 11-16-16	CHK MCIS	SCALE NONE	SHT 4 OF 6	SIZE A
-----------------	------------------	-------------	---------------	------------	-----------

2

1

THIS COPY IS PROVIDED ON A RESTRICTED BASIS AND IS NOT TO BE USED IN ANY WAY DETRIMENTAL TO THE INTERESTS OF PANDUIT CORP.

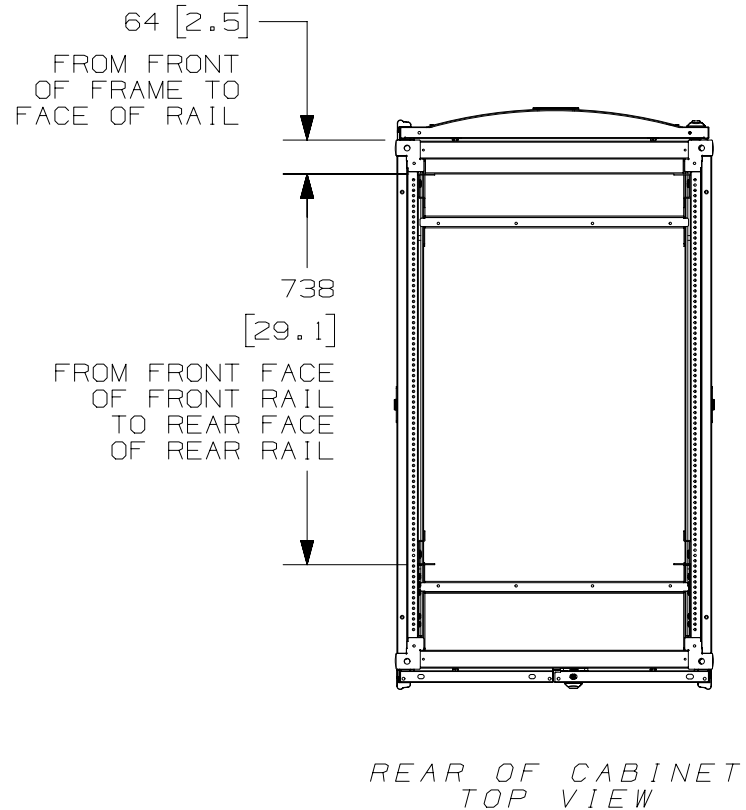
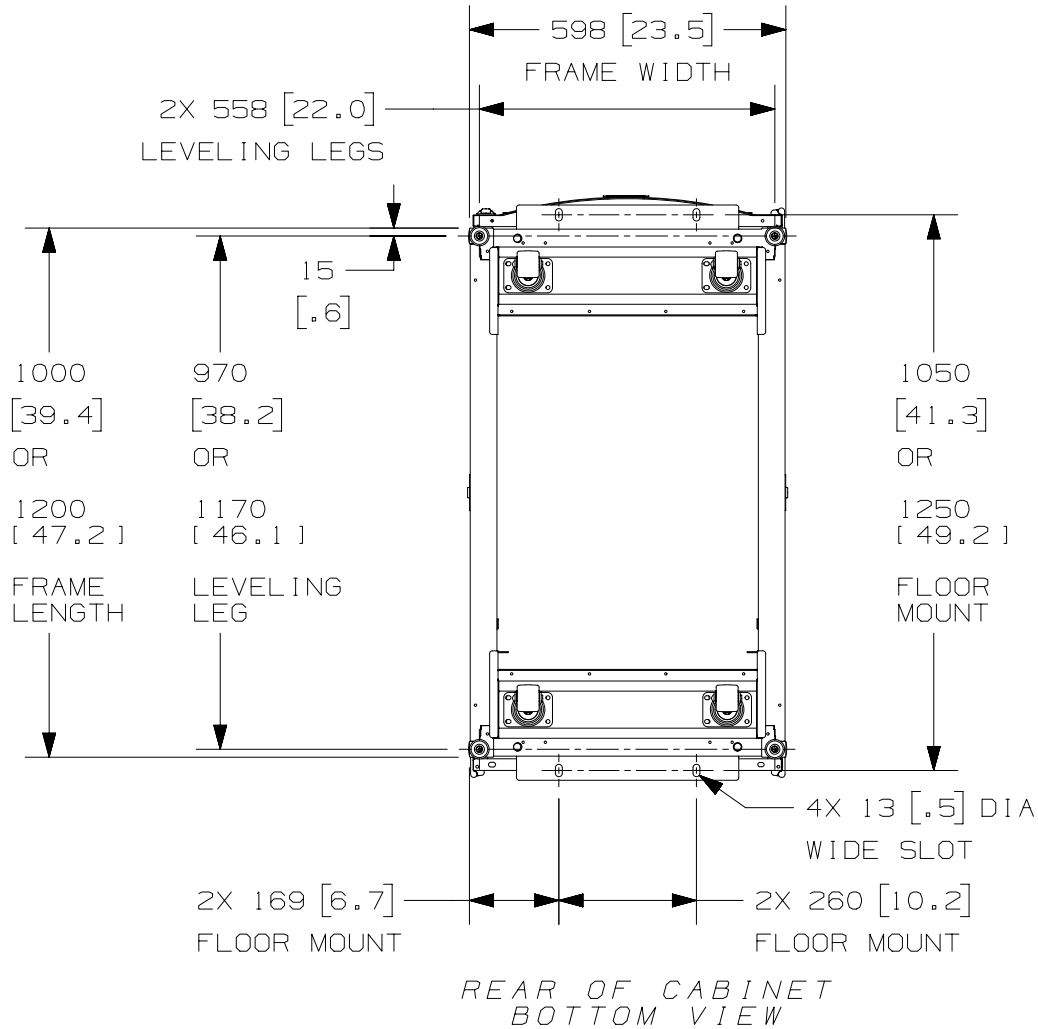

SOME PARTS REMOVED FOR CLARITY

00A	11-16-16	LEE	MCIS		SEE SHEET ONE FOR REVISIONS	V09001BI/03
REV	DATE	BY	CHK	APR	DESCRIPTION	ECN

TITLE NET-VERSE D-TYPE CABINET 600 WIDE X 42/45 RU X 1000mm/1200mm DEEP (DN6***B) CUSTOMER DRAWING					
ITEM REVISION NAME 00083FAA/00	PANDUIT				
DATASET FILE NAME 00083FAA_DC_00A					
MATERIAL: N/A					
DRAWING NUMBER: 00083FAA-DC					
THIRD ANGLE PROJECTION					
DRAWN BY LEE	DATE 11-16-16	CHK MCIS	SCALE NONE	SHT 5 OF 6	SIZE A

D10100DA/16

THIS COPY IS PROVIDED ON A RESTRICTED BASIS AND IS NOT TO BE USED IN ANY WAY DETRIMENTAL TO THE INTERESTS OF PANDUIT CORP.

TOP CAP OPENING CABLE CAPACITY								
	AREA		CABLE CAPACITY* (CABLE DIA)					
	CM ²	IN ²	CAT 6A (8.99mm)	CAT 6A (7.87mm)	CAT 6A (7.54mm)	CAT 6 (6.35mm)	CAT 5e (4.75mm)	FIBER (3mm)
84mm x 476mm FRONT AND REAR OPENINGS (EACH)	339.6	61.9	251	328	358	504	902	2261

* CAPACITY CALCULATION ASSUMES 40% FILL FACTOR

TITLE		NET-VERSE D-TYPE CABINET 600 WIDE X 42/45 RU X 1000mm/1200mm DEEP (DN6***B) CUSTOMER DRAWING		
ITEM REVISION NAME		00083FAA/00		PANDUIT
DATASET FILE NAME		00083FAA_DC_00A		
DRAWN BY		LEE		MATERIAL: N/A
DATE		11-16-16		
CHK		MCIS		DRAWING NUMBER: 00083FAA-DC
SCALE		NONE		
REV		SHT 6 OF 6		SIZE A

00A	11-16-16	LEE	MCIS	SEE SHEET ONE FOR REVISIONS	V09001BI/03	
REV	DATE	BY	CHK	APR	DESCRIPTION	ECN

D:\10100DA\16