

THIS COPY IS PROVIDED ON A RESTRICTED BASIS AND IS NOT TO BE USED IN ANY WAY DETRIMENTAL TO THE INTERESTS OF PANDUIT CORP.

SEE DETAIL A

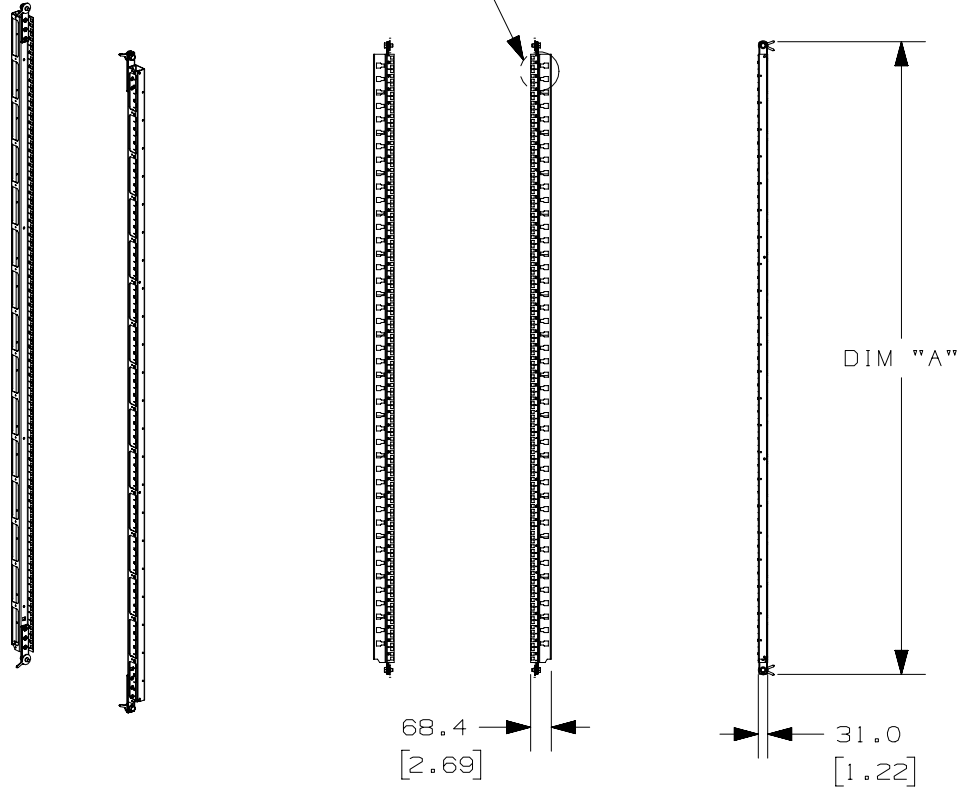

PART NO.	DESCRIPTION	DIM "A"	"HH"	WEIGHT
SN2RC	N-TYPE AND S-TYPE CABINET 42RU CAGE NUT EQUIPMENT RAIL	1879.3 [73.99]	42	15.86 Kg/EACH [35.0 LBS/EACH]
SN5RC	N-TYPE AND S-TYPE CABINET 45RU CAGE NUT EQUIPMENT RAIL	2012.6 [79.24]	45	16.78 Kg/EACH [37.0 LBS/EACH]
SN8RC	N-TYPE AND S-TYPE CABINET 48RU CAGE NUT EQUIPMENT RAIL	2146.0 [84.49]	48	17.69 Kg/EACH [39.0 LBS/EACH]
SN1RC	N-TYPE AND S-TYPE CABINET 51RU CAGE NUT EQUIPMENT RAIL	2279.3 [89.74]	51	18.60 Kg/EACH [41.0 LBS/EACH]

- VISIT OUR ON-LINE CATALOG AT WWW.PANDUIT.COM FOR A LIST OF CURRENT PARTS APPLICABLE FOR USE WITH THIS PRODUCT.
- PARTS SUPPLIED:
 - 1- SET CAGE NUT EQUIPMENT RAILS
 - 1- HARDWARE KIT
 - 1- INSTRUCTION SHEET
- PRIMARY DIMENSIONS ARE IN MILLIMETERS.

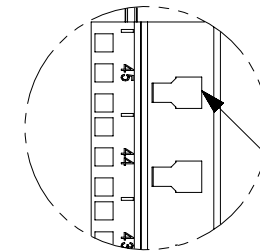

COMPATIBLE WITH
SN15F AND SN25F
CABLE MANAGEMENT
FINGERS

DETAIL A
SCALE 1 : 4

ISO VIEW

FRONT VIEW

SIDE VIEW

TITLE
SN*RC NET-ACCESS N-TYPE AND S-TYPE
CABINET FAMILY CAGE NUT EQUIPMENT
RAILS
CUSTOMER DRAWING

ITEM REVISION NAME
13V398ZY/00.PRT

DATASET FILE NAME
13V398ZY_DC/00A.PRT

PANDUIT

MATERIAL:

N/A

DRAWING NUMBER:
13V398ZY-DC

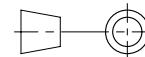

THIRD ANGLE
PROJECTION

REV	DATE	BY	CHK	APR	DESCRIPTION	ECN
00A	2-04-15	PBS	RCHA	RCHA	RELEASED TO PRODUCTION	V09000DJ

DRAWN BY PBS	DATE 2-04-15	CHK RCHA	SCALE NONE	SHT 1 OF 1	SIZE A
-----------------	-----------------	-------------	---------------	------------	-----------