



**Ring Terminal
T&B Catalog Number:**

E6-10
78621080357
Active

**UPC Number:
Status:
Description:**

Non-Insulated Large Brazed Seam Ring Terminal, Length 1.13 Inches, Width .48 Inches, Bolt Hole #10, Wire Range #6 AWG, Copper, Tin Plated, 20 Pack

Features

These non-insulated ring terminals are made of electrolytic copper for high conductivity. They can be installed with crimping tools having a single indenter or double indenter (recommended for solid wire). Serrated barrel increases grip on wire.

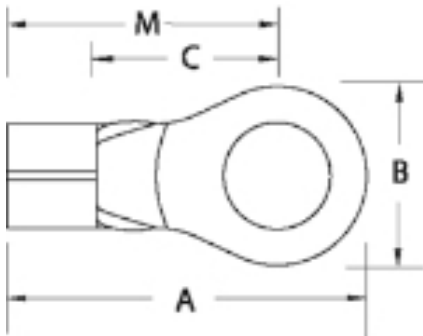

General

Insulation Type	Non-Insulated - Brazed Seam
Terminal Series	E
Material	Copper
Finish	Electro -Tin Plated
Color	Metallic
Wire Range	6
Stud Size	#10

Dimension Information

Stock Thickness	.06
A (inches)	1.13
B (inches)	.48
C (inches)	.36
M (inches)	.90

Specifications

Temperature Rating	150°C
Voltage Rating	600V
Flammability Rating	UL 94 V-0

Tooling

Tool Charts	Available on Website
Application Tools	WT115A, TBM6, TBM6S, WT3185
Recommended Tool	TBM6S

Packaging

T&B Order Multiple	20
T&B Inner Pack	20
Package in Units	100
Package Type	Standard
T&B Sold in UOM	Each
T&B Weight Per UOM	1.63 lbs. per 100
Alternate Package Qty	E26

Application Support

Overview	Available on Website
Wire Guide Tables	Available on Website

Notes

Not available on Mylar Tape.

Certifications

RoHS Compliance Yes

Certifications



File Nbr:
E9809

For further technical assistance, please contact us...

Thomas & Betts - USA
8155 T&B Blvd.
Memphis, TN 38125
www.tnb.com

T&B Technical Support
MS 3B-50
8155 T&B Blvd.
Memphis, TN 38125

Hours: 7AM - 6PM CDT
Monday-Friday
Phone: (888) 862-3289
Fax: (901) 252-1321
Email: techsupport@tnb.com