

HD Flex™ Fiber Patch Panel

specifications

The patch panel shall house and organize, fiber optic cable, terminations, splices and connectors. Patch panel shall accommodate all HD Flex™ cassettes, fiber adapter panels (FAP), trunk cables, connectors and patch cords. Patch panel shall provide front and rear access, regardless of how many are stacked together. Patch panel shall allow cassettes and FAPs to be installed by sliding them into the front or the rear of the patch panel which allows each individual cassette/FAP to be removed with minimal disruption to other cassettes/FAPs. Patch panel shall be able to be adapted to accept either 6-port cassettes/FAPs and 12-port cassettes/FAPs.



technical information

Mounting:	Integral mounting flange for installation in 19" wide EIA-310 racks
Material:	Steel patch panel

key features and benefits

Modular design accepts up to 12 HD Flex™ Fiber Cassettes or Fiber Adapter Panels per rack unit	Provides higher patch field density in fewer rack units saving valuable rack space
Compatible with all HD Flex™ Fiber Cassettes and Fiber Adapter Panels	Provides versatility and flexibility with a fully modular solution for a variety of pre-terminated installations
Rack/Cabinet Rail Mounting Cable Management Bracket	Provides template for additional mounting of cables, moving cable from back of enclosure to side of enclosure resulting in easy access to connections for improved serviceability
Front and Rear Accessibility	Allows access to connections from front or rear of rack/cabinet facilitating easy moves, adds and changes without disruption of network connections
Ultra-light Weight	Makes the patch panel easy to install within or above a cabinet or rack.
Convertible between 6-port and 12-port Cassettes and Fiber Adapter Panels	Allows each half of tray to operate independently providing improved reliability and serviceability of redundant network connections

applications

HD Flex™ Fiber Optic Enclosures and Patch Panels provide a system for managing fiber terminations, connections, and patching in all types of applications. The patch panel is a component of the HD Flex™ Fiber Cabling

System. It is ideal for fast, flexible and reliable patch field solutions within main, horizontal and/or equipment distribution areas (MDA, HDA and EDA).

HD Flex™ Fiber Patch Panel

1 RU 6-port panel:	FLEX1UPN06
1 RU 12-port panel:	FLEX1UPN12
2 RU 6-port panel:	FLEX2UPN06
2 RU 12-port panel:	FLEX2UPN12
4 RU 6-port panel:	FLEX4UPN06
4 RU 12-port panel:	FLEX4UPN12

HD Flex™ Trunk Transition Clips

12-fiber capacity:	FLEX-CLIP12
18-fiber capacity:	FLEX-CLIP18

HD Flex™ Trunk Cable Managers

Rear Cable Managers

1 RU:	FLEX-RCM1U
2 RU:	FLEX-RCM2U
4 RU:	FLEX-RCM4U

Universal Trunk Managers

12-fiber transition capacity:	FLEX-CM12S
18-fiber transition capacity:	FLEX-CM18S

PatchRunner™ Trunk Managers

12-fiber transition capacity:	FLEX-CM12C
18-fiber transition capacity:	FLEX-CM18C

HD Flex™ Trunk Slack Plates

1 RU:	FLEX-PLATE1U
4 RU:	FLEX-PLATE4U

HD Flex™ Fiber Patch Panel

fiber capacity

Description	Patch Panel		
	1 RU	2 RU	4 RU
12F MPO to 6 Duplex LC	144	288	576
24F MPO to 12 Duplex LC	144	288	576
4-to-1 Breakout	96	192	384
12-to-3 Breakout	144	288	576
6 Port 12F MPO FAP	864	1728	3456
6 Port 24F MPO FAP	1728	3456	6912

For dimensions, please go to www.panduit.com for the part drawings.

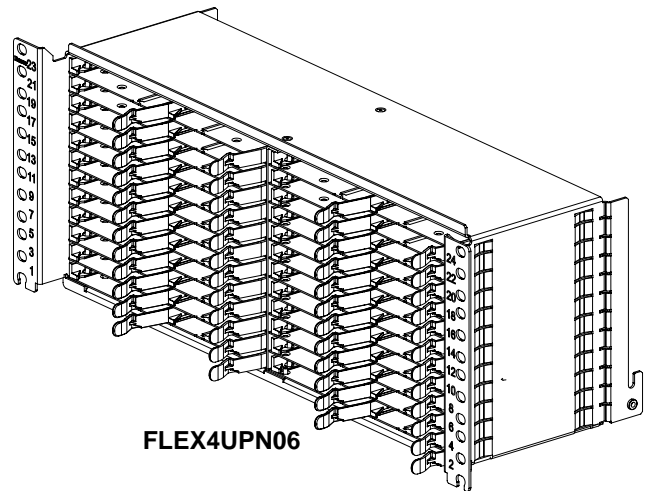
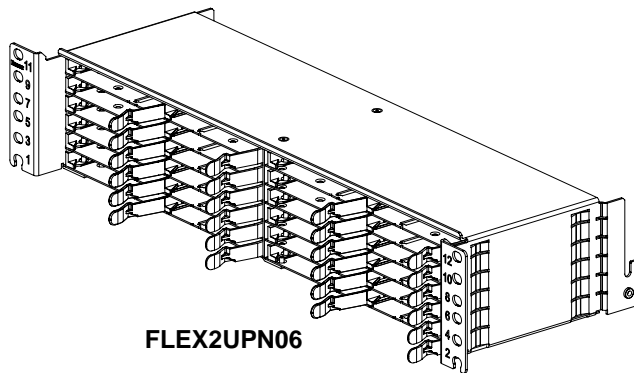
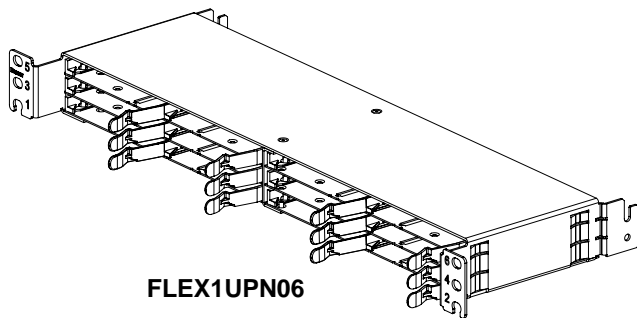

Dimensions are in inches.

WORLDWIDE SUBSIDIARIES AND SALES OFFICES

PANDUIT CANADA
Markham, Ontario
cs-cdn@panduit.com
Phone: 800.777.3300

PANDUIT EUROPE LTD.
London, UK
cs-emea@panduit.com
Phone: 44.20.8601.7200

PANDUIT SINGAPORE PTE. LTD.
Republic of Singapore
cs-ap@panduit.com
Phone: 65.6305.7575

PANDUIT JAPAN
Tokyo, Japan
cs-japan@panduit.com
Phone: 81.3.6863.6000

PANDUIT LATIN AMERICA
Guadalajara, Mexico
cs-la@panduit.com
Phone: 52.33.3777.6000

PANDUIT AUSTRALIA PTY. LTD.
Victoria, Australia
cs-aus@panduit.com
Phone: 61.3.9794.9020

For a copy of Panduit product warranties, log on to www.panduit.com/warranty

For more information

Visit us at www.panduit.com

Contact Customer Service by email: cs@panduit.com
or by phone: 800.777.3300

PANDUIT®

©2016 Panduit Corp.
ALL RIGHTS RESERVED.
FBSP120--WW-ENG
2016-06-29