

8000 Series Hybrid NVR

32 and 16-Channel Recording Platforms



The most powerful, reliable, feature-rich hybrid NVR in the industry. The 8000 Series Hybrid NVRs deliver video that's always there when you need it, and the advanced tools that allow you to quickly find the evidence you need. Our solutions help you get your job done faster — from installation to investigation — with these appliance-based hybrid NVRs as the backbone. They reinforce our reputation for manufacturing the most robust, reliable, and feature-rich recorder on the market, and allow you to migrate from 100% analog to 100% IP video at your own pace. The NVRs work in conjunction with our March Networks Command VMS platforms, which are flexible, scalable and easy to use. Command will save you time and simplify your video surveillance system management.



ALTERNATE STREAM SUPPORT ON IP CAMERAS

For IP cameras, the recorder can accommodate up to two simultaneous recording streams. Different streams can be used for different purposes. For example, one stream could be for live viewing on the web so you need low bit-rate (which means lower resolution and compression). The second stream could be for recording at full resolution and full frame rate for investigation purposes.

THE PURPOSE-BUILT ADVANTAGE

Our recorders are embedded, Linux-based, purpose-built devices, designed to record video 24/7. Customers are looking for a recording solution that allows them to spend more time performing investigations and less time dealing with maintenance issues that can plague a PC-based recorder.

UNPARALLELED SCALABILITY

From the small, local-control user with just a few cameras, who does not want to connect the recorder to a network...to the largest enterprise user with globally dispersed sites and thousands of recorders... the 8000 series NVR recording and management suite has a solution that will feel tailor-made to fit your unique application.

WE'VE GOT YOU COVERED

The 8000 series recorders incorporate an impressive breadth of security features to ensure your data is protected and your hardware continues to function. The internal battery backup guarantees a systematic shutdown in the event of an unexpected power loss. Hard drive mirroring ensures redundancy and allows for flexible use of storage. The built-in firewall guarantees that your network will comply with your IT department's guidelines. Watchdog circuitry for both hardware and software ensures that the recorder remains operational. And secure tunneling grants access only to authenticated users when it comes to devices connected to the recorder's camera network.

USE ANALYTICS TO IMPROVE YOUR BUSINESS

Our optional analytics can be integrated to address the unique needs of retailers and banking institutions of all sizes, and help them leverage their security investment and use video, combined with reporting tools, to analyze and improve their business.

FEATURES

- 16 and 32-channel models
- Choose from:
 - R-series (rack mount)
 - S-series (stack mount)
- Full Hybrid NVR solution to support both analog and IP, or 100% IP
- High and low frame rate streams on IP cameras
- Alternate stream support on IP cameras
- Embedded, Linux-based recorders
- Scan QR code on front panel to retrieve system information and reduce maintenance time
- Sophisticated configurable recording policies based on schedule, motion, analytics, etc.
- Real-time health monitoring of cameras, recorders, and network
- Network policies for bandwidth protection
- Local display of both analog and IP cameras (HDMI and composite)
- Local control (interface standard on all models)
- Industry-leading interfaces to third party applications, including POS, ATM, teller, LPR, and access control
- Optional advanced video analytics

Helping integrators save time and money.

- ✓ Check warranty status
- ✓ Get express RMA
- ✓ Get in-field diagnostics support
- ✓ Do wireless provisioning in the field



March Networks Command Video Management Software

Flexible, scalable and easy-to-use.

Command Enterprise is designed for simplicity and ease of use, which saves on training time and provides a smooth learning curve, allowing users to focus on their job.

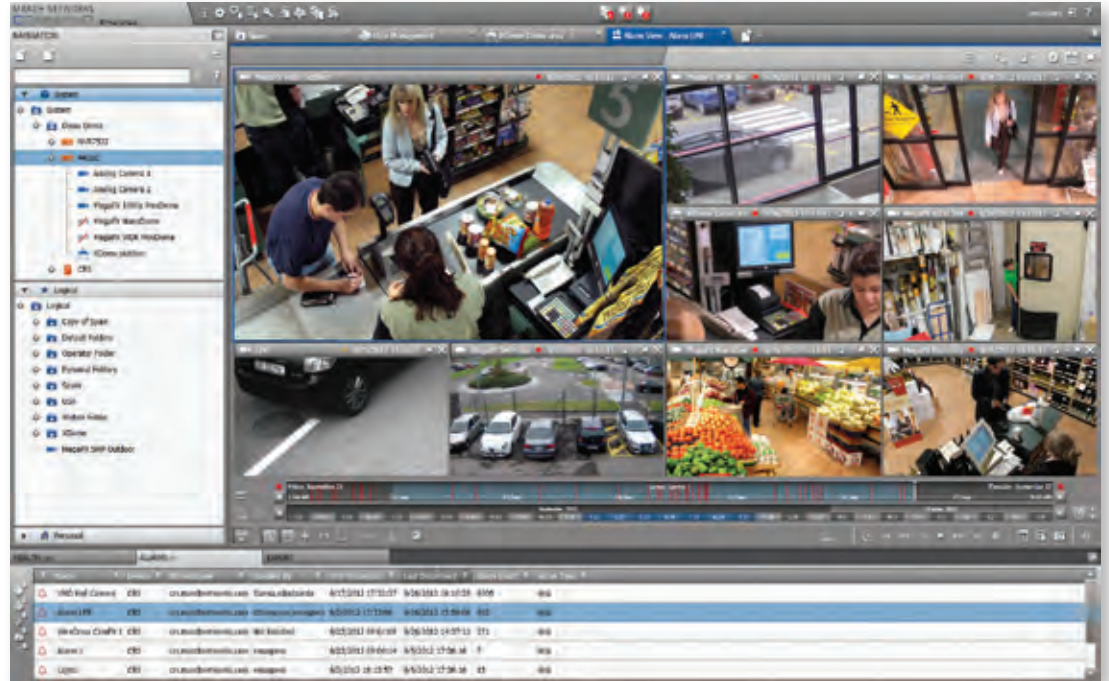

The scalability you need

No matter what your business or its size, Command can scale to meet your needs. Customizable and easy to use, our powerful VMS platform delivers the features and tools you need to easily manage your video surveillance system — and none of the ones you don't.

Enterprise video management made easy

Save time with Command's advanced mass management and remote health monitoring tools. Rapidly identify system issues, configure devices and apply updates, all with a few clicks of your mouse.

Faster investigations

Tired of spending hours searching through video archives? Find the evidence you need in just minutes with advanced search tools that let you rapidly sort through images and

zero-in on the exact timeframe you need to investigate. With Command, you can also selectively record on motion, so you gather only the video you need.

Advanced alarm monitoring

Command's sophisticated alarm monitoring tools enable you to rapidly respond to critical situations. View live and archived video, and access audio and event data in seconds. Configure customized actions and responses, such as email notifications.

Making Your Job Easier

March Networks Cloud

View your video on the go from your iOS/Android tablet or phone. It's Cloud-based, so no software downloads or updates are required, and it provides unlimited user access with no impact on recorder performance.

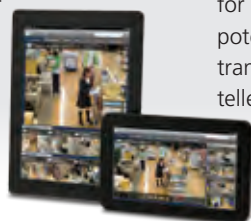

Searchlight for Banking and Searchlight for Retail

The most cost-effective and robust software on the market today for investigating potentially fraudulent transactions at POS, teller, or ATM locations.



March Networks Managed Services

Leverage the expertise of skilled technicians at March Networks' 24/7 Network Operations Center to remotely monitor and manage your video systems. We will identify and initiate action on any system issues before they can affect performance.

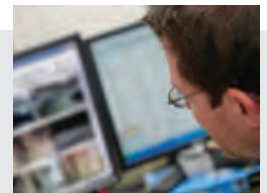

The Recorder

Available in 16 and 32-channel models, this recorder's full hybrid capabilities can bring you from 100% analog to 100% IP at your own pace. Multi-level H.264 encoding, scalable, reliable, backward-compatible and purpose-built for all your video, security, and management needs. This is truly the powerhouse behind the scenes.

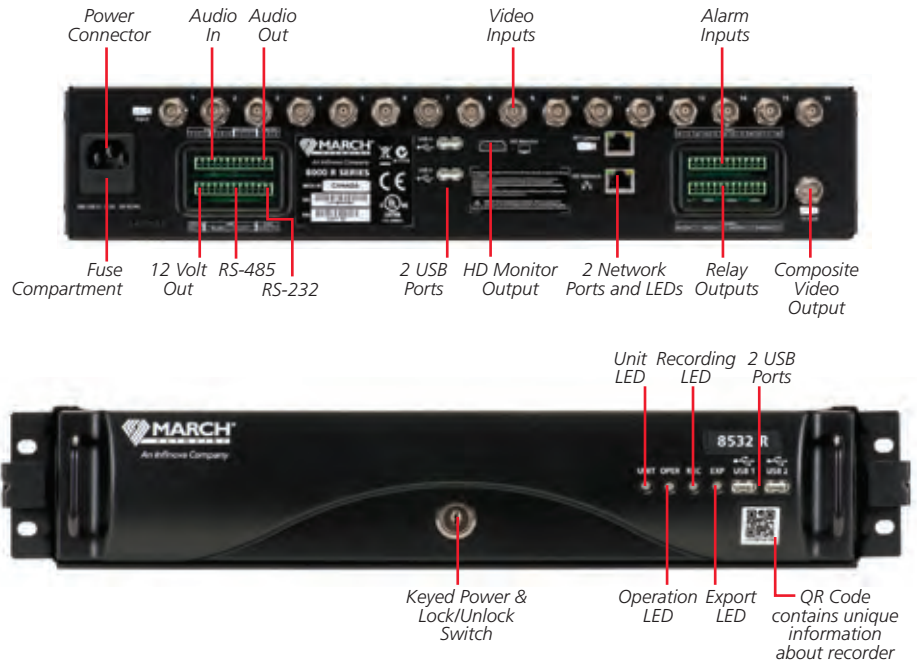

R-series

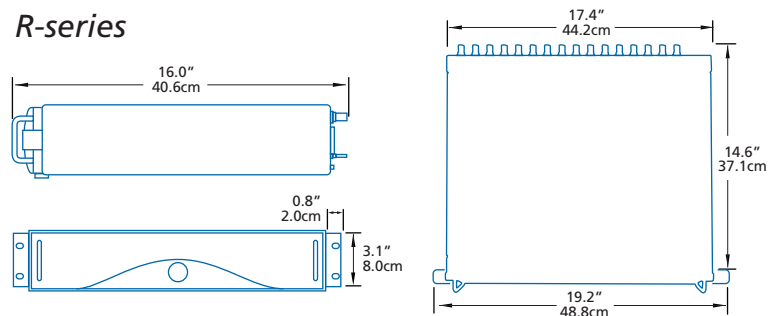

Dock It And Lock It

The only recorders in the industry to feature the innovative "dock and lock" station. Similar to the one designed for your PC, this docking station keeps all connections clean and securely connected to the back of the unit and allows for quick, easy installation of the recorder, as well as removal for service and maintenance. In addition, a lock switch turns the recorder on/off and locks it to the docking station, preventing removal, tampering or unauthorized shutdown of the recorder.



March Networks System Design Tool

Generate approximate storage and bandwidth estimations based on a variety of settings that you provide. Available via your desktop and mobile devices (iPad, iPhone and Android devices).



March Networks GURU Smartphone App

Available as a free download from the App Store and Google Play, this industry-first smartphone app enables partners to initiate an RMA, review and change recorder IP addresses, register/unregister from the ESM, go through SSH to view storage information, access diagnostics and service information (including product warranty and RMA shipment status), and more.



8000 Series Hybrid NVR

MODELS

8732 R-series	32 channels, 30fps, rack mount
8532 R-series	32 channels, 15fps, rack mount
8532 S-series	32 channels, 15fps, stacked
8516 R-series	16 channels, 15fps, rack mount
8516 S-series	16 channels, 15fps, stacked

VIDEO

Analog Capacity	<p>8732 R 30fps concurrent at full 4CIF/2CIF/CIF across 32 channels (480fps)</p> <p>8532 R 15fps concurrent at full 4CIF/2CIF/CIF across 32 channels (240fps)</p> <p>8532 S 15fps concurrent at full 4CIF/2CIF/CIF across 32 channels (240fps)</p> <p>8516 R 15fps concurrent at full 4CIF/2CIF/CIF across 16 channels (240fps)</p> <p>8516 S 15fps concurrent at full 4CIF/2CIF/CIF across 16 channels (240fps)</p>
------------------------	---

Video Compression	H.264, CIF/2CIF/4CIF resolution
--------------------------	---------------------------------

Max Analog/IP Camera Inputs	16/32
------------------------------------	-------

IP Camera Performance

8732 R, 8532 R, 8532 S	<p>With all analog cameras enabled, IP camera capacity = 48 Mbps</p> <p>With all analog cameras disabled, IP camera capacity = 96 Mbps (3Mbps / camera)</p> <p>With alternate stream enabled, IP camera capacity = 72 Mbps (2.25 Mbps / camera)</p>
8516 R, 8516 S	<p>With all analog cameras enabled, IP cameras are not available</p> <p>With all analog cameras disabled, IP camera capacity = 48 Mbps (3Mbps / camera)</p> <p>With alternate stream enabled, IP camera capacity = 32 Mbps (2.25 Mbps / camera)</p>

Video Output	Composite or HDMI
---------------------	-------------------

AUDIO

Analog Audio Inputs	4, unbalanced, 10kΩ, 1Vp-p typical
----------------------------	------------------------------------

Analog Audio Outputs	2, unbalanced, 600Ω, 1Vp-p
-----------------------------	----------------------------

Analog Audio Codec	G.711, 8 bit/8kHz, 64 kBit/s, unidirectional
---------------------------	--

NETWORK

Network 1	GigE port for connection to corporate network
------------------	---

Network 2	GigE port for connection to camera network
------------------	--

Security	Industry standard TLS 1.2 with strong AES encryption, HTTPS encryption, strong hashing algorithms SHA256, continuous security vulnerability assessment
-----------------	--

Interface	10/100/1000Base-T Ethernet (2 x RJ-45)
------------------	--

SYSTEMS / NETWORK MANAGEMENT

Bandwidth Throttle	Yes (can include exceptions on a per-IP address basis)
---------------------------	--

Bandwidth Scheduling	Yes
-----------------------------	-----

Adaptive Bandwidth	Yes
---------------------------	-----

Remote Connection	TCP/IP (IPv4)
--------------------------	---------------

Concurrent Remote Connections	No set limit
--------------------------------------	--------------

Internal Battery	Enables systematic shutdown; no external UPS communication required
-------------------------	---

ANALYTICS

Included	Motion detection
Optional	Camera obstruction, field-of-view monitoring, trip wire, loitering

STORAGE

Internal Hard Drives	1-4 3.5" HDDs
-----------------------------	---------------

Individual Drive Capacity	Up to 8TB
----------------------------------	-----------

Total Storage Capacity	Up to 32TB
-------------------------------	------------

Drive Type	Serial ATA (SATA)
-------------------	-------------------

Mirroring	Yes
------------------	-----

ALARM INPUTS/OUTPUTS

Alarm Inputs	8 current loop inputs, supporting open and closed detection
---------------------	---

Relay Outputs	4 relay switch outputs (30VDC, 1A); programmable event driven
----------------------	---

PHYSICAL

Dimensions (HxWxD)

R-series	3.1 x 17.4 x 16.0 in (8.0 x 44.2 x 40.6 cm)
-----------------	---

S-series	3.2 x 16.9 x 16.0 in (8.1 x 43.0 x 40.6 cm)
-----------------	---

Mounting

R-series	2U high, 19" rack, wall mount and desktop
-----------------	---

S-series	Wall mount and desktop
-----------------	------------------------

Weight

R-series	18.5 lbs (8.4 Kg) (with docking station)
-----------------	--

S-series	13 lbs (5.9 Kg) (no docking station)
-----------------	--------------------------------------

Hard Drive	Add 1.5 lbs (0.7 Kg) per HDD
-------------------	------------------------------

ENVIRONMENTAL

Operating Temperature	5°C to 40°C (41°F to 105°F)
------------------------------	-----------------------------

Heat Dissipation	Maximum 255 BTU per hour (system plus 4 hard drives)
-------------------------	--

Humidity	5% to 95% RH (non-condensing)
-----------------	-------------------------------

Storage Conditions	-40°C to 70°C (-40°F to 158°F)
---------------------------	--------------------------------

ELECTRICAL

Internal Power Supply	115/230 VAC (auto-sensing), 2.3A, 50-60Hz
------------------------------	---

Power Consumption	75W Max
--------------------------	---------

REGULATORY

Safety	IEC60950-1 (ed.2), UL 60950-1 (ed.2), CSA C22.2 No. 60950-1-07 (ed.2)
---------------	---

EMC	FCC 47 CFR Part 15, Subpart 15, ICES-003, EN55022, CISPR 22, AS/NZS CISPR 22, EN61000-3-2, EN 61000-3-3, EN50130-4, EN55024
------------	---

Compliance Marking	CE-mark, cULUs, C-tick, WEEE
---------------------------	------------------------------

2-year Advance Replacement plan on all NVRs:

- Options for Repair & Return or Advance Replacement
- March Networks incurs all shipping costs—both ways—for AR's
- All NVR components are covered, including HDDs