

# RE97-2TX Low Profile, Head-worn, Condenser Microphone with TA4F Connector



- Superior Sound Quality
- Omni-directional Polar Pattern
- Lightweight, Low Profile, and Rugged
- Adjustable Head-Band and Boom
- Swivel Earloops Allow for Left or Right Side Use



The Electro-Voice RE97-2Tx is a low profile, omni-directional, condenser microphone designed for demanding applications where a hands-free microphone is required. The RE97-2Tx is intended for spoken-word use in theatrical performance, corporate AV presentations, fixed installations, houses of worship, or any venue where a fullrange, natural, and well-balanced sound is required from an inconspicuous, lightweight, head-worn microphone. The output of the RE97-2Tx is clean and accurate, while the omni-directional polar pattern ensures uniform output regardless of the microphone's angle relative to the sound source. The RE97-2Tx head-band is easily adjusted to fit virtually any head size, is light in weight, and provides a stable base for the microphone boom.

The microphone boom can be easily adjusted for optimum placement near the user's mouth by sliding the boom forward and backward along the headband. The microphone boom is made of special, malleable stainless steel that may be shaped to better match facial contours. The earloops are designed for full 360° rotation, allowing for microphone usage on either side of the head, as well as convenient flat storage when not in use.

The supplied windscreen can be utilized in windy environments and to reduce breath noise. The RE97-2Tx has a shielded 4ft cable terminated in a genuine Switchcraft TA4F connector and is ready for use with standard EV and Telex body-pack transmitters including the EV REV-BP, BPU-2/CSB-1000 and Telex WT-500/WT-1000. The wire to the body-pack may be conveniently routed behind the user and attached to a shirt collar with the included clothing clip.

## Technical specifications

<b>Transducer:</b>	Condenser, back-electret
<b>Frequency Response:</b>	50 – 15 kHz
<b>Polar Pattern:</b>	Omni-directional
<b>Sensitivity, 1 kHz:</b>	-48 dBV, 4.0 mV/Pascal
<b>Maximum SPL:</b>	>125 dB SPL
<b>Equivalent Noise:</b>	32 dBA
<b>Dynamic Range:</b>	93 dB
<b>Output Impedance, 1 kHz:</b>	3000 Ω
<b>Power Requirements:</b>	+5 VDC

<b>Current Consumption:</b>	310 $\mu$ A
<b>Polarity:</b>	Positive Pressure on Diaphragm Produces a Positive Voltage on pin 2
<b>Dimensions:</b>	See diagram
<b>Cable:</b>	4 ft (1.22 m) long; 0.052 in (1.30 mm) diameter
<b>TA4F Connector Wiring:</b>	Pin 1 – Ground Pin 2 – Audio Pin 3 – Bias Voltage Pin 4 – Unused
<b>Accessories Furnished:</b>	Windscreen Clothing Clip Gig Bag
<b>Color Available:</b>	Beige
<b>Net Weight:</b>	0.6 oz (17 g) Mic and headset only: 0.33 oz (9.4 g)
<b>Optional Accessories:</b>	TXA Phantom Power Adapter

## System overview

### Application Notes:

#### Using your RE97-2Tx

##### Earloops:

The RE97-2Tx arrives with the earloops in the flat storage position. To change the position of the earloops, first pull the base of the earloop straight away from the headband while gripping the cylindrical connector (Figure 1).

Next, rotate the earloop 90 degrees, and release. The earloop will “lock” into place when positioned correctly. To replace the RE97-2Tx in the gig bag, repeat this procedure to flatten the earloops. Note: You may wear the mic boom on either side of the face. To change sides, simply rotate both earloops 180 degrees.

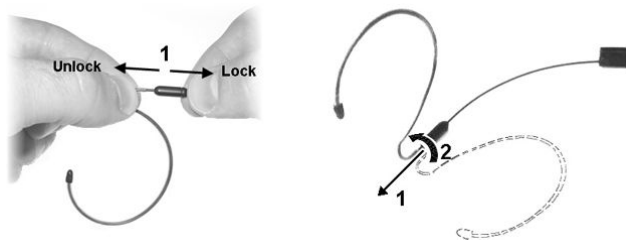

Figure 1. Unlocking and Rotating the Earloops

##### Headband and Microphone Placement:

Before placing on the user’s head, expand the headband to the largest position by moving the sliders toward each other until they almost touch (Figure 2).

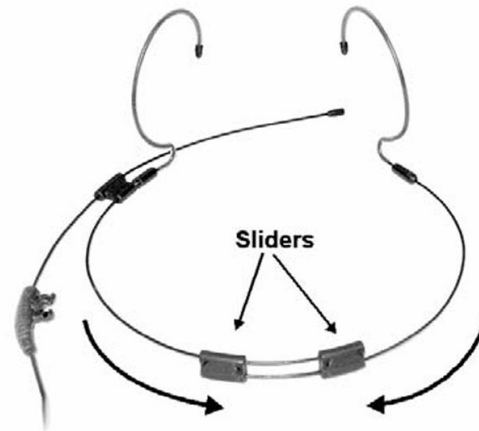

Figure 2. Headband in the Largest Position

Place the earloops on the user’s ears and then pull the sliders apart, towards the ears, tightening until the headband fits firmly yet comfortably (Figure 3). Adjustments may be made for additional comfort or stability by gently bending the earloops (Figure 4).

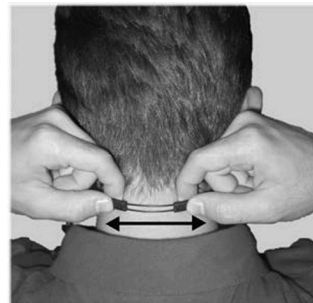

Figure 3. Adjusting the Headband

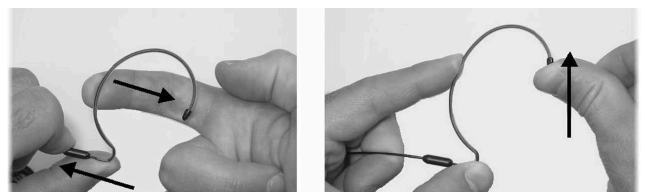

Figure 4. Changing the Earloop Shape

**Microphone Positioning:**

The ideal placement of the microphone is ½ inch behind the corner of the mouth and ½ to 1 inch away from the face. The signal-to-noise ratio is optimized and breath noise is minimized in this configuration (Figure 5).

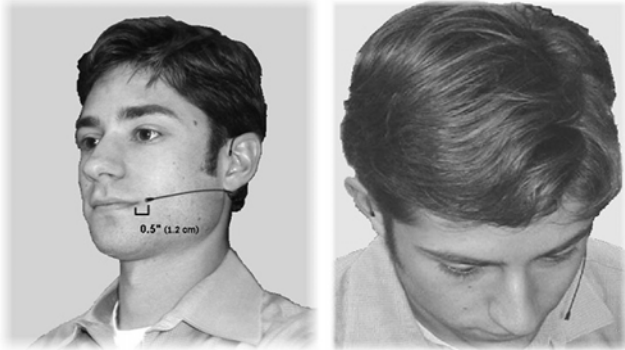

Figure 5. Suggested Placement

**Adjusting the Microphone Boom:**

The three-pronged snap on the strain relief at the back end of the microphone boom can be placed anywhere along the headband. Simply pull the strain relief off of the headband, move the boom and microphone to the desired position, and snap the strain relief back on to the headband (Figure 6).

A slight bend can be put into the boom for ideal placement of the microphone near the corner of the mouth. **Note: Although the microphone boom is designed to be malleable, permanent damage to the microphone may result if bent at an angle exceeding 45 degrees.** To adjust, gently bend the boom a small amount at multiple locations or around a curved object rather than bending it sharply at one point (Figure 7a and Figure 7b).

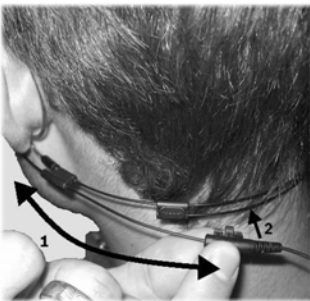

Figure 6. Adjusting the Microphone Boom



Figure 7a. Do Not Bend Mic Boom Sharply

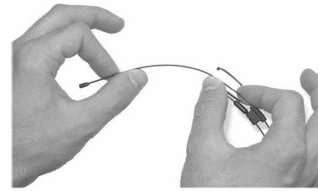

Figure 7b. Shaping the Mic Boom Gently

**Using the Clothing Clip:**

The microphone cable should be routed behind the neck of the user and secured in place with the supplied clothing clip. Allow some slack in the cable to enable the user’s head complete range of motion in both directions without pulling the cable from the clothing clip (Figure 8).

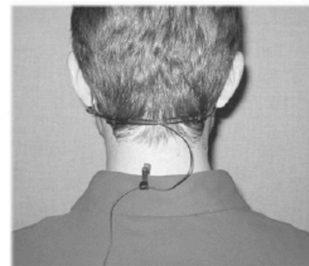

Figure 8. Using the Clothing Clip

**Windscreen Assembly:**

The windscreen assembly is supplied with a plastic adaptor to improve stability.

To apply: Hold the windscreen firmly at the “A” locations. Firmly press the microphone into the adaptor until it stops.

**NOTE:** Use caution when removing the microphone from the windscreen. Do not pull on product wire: grip microphone by metal housing only.

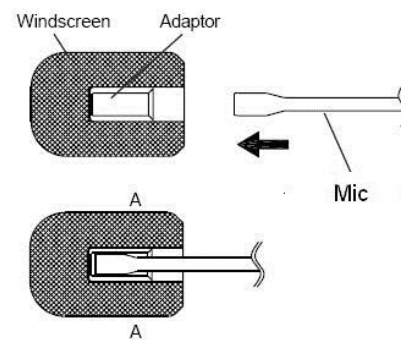

Windscreen Assembly

#### 4 | RE97-2TX Low Profile, Head-worn, Condenser Microphone with TA4F Connector

##### Interfacing Microphones:

Your microphone is configured for use with standard Electro-Voice and Telex bodypack transmitters. Modifications to your microphone should be performed by a qualified technician only. Using the microphone in a way other than described in this document may damage the microphone and void your warranty.

The following table is provided for your reference should you desire to utilize the microphone with another manufacturer's wireless transmitter bodypack. Always verify the specifications of your transmitter before attempting any changes to your microphone.

Manufacturer	Wireless Systems	Connector Type	Suggested Wiring
AKG	WMS 40 Pro, WMS 400, and WMS4000 (Transmitters PT 40, PT400, and PT4000)	TA3F	Pin 1: Shield Pin 2: Wire Jump Pin 2 to Pin 3
Audio-Technica	AT UniPak-type Transmitters ATW-1127, ATW-1235, ATW-1451, ATW-2110, ATW-3110a, AEW-T1000, ATW-201, ATW-601, ESW-T210, and ESW-T211 for the following systems: 1100, 1200, 1400, 2000, 3000, 4000, and 5000 Series Professional; 200 and 600 Series Freeway; NOT for use with U100 System	Hirose 4-pin HR10A-7P-4S	Pin 1: Shield Jump Pin 1 to Pin 2 Pin 3: Wire Shunt Pins 3-4 with R=5k Ω
Electro-Voice	RE-2 (BPU-2); RE-1 (CSB-1000); R100 (BPV)	TA4F	Pin 1: Shield Pin 2: Wire Shunt Pins 2-3 with R=10 Ω Pin 4: Not Connected
Sennheiser	Evolution Wireless Systems 100, 300, 500 (Transmitters SK100, SK300, SK500), and G2 Series	3.5 mm (1/8 in) Stereo or Mono Mini-Plug	Tip: Wire Sleeve: Shield Ring: Not Connected

Manufacturer	Wireless Systems	Connector Type	Suggested Wiring
			5V Zener diode: + to tip, - to sleeve (1N5231 or similar)
Shure	Performance Gear (UT1); PGX1; SLX1; T Series (T1, T11); UC1; UHF (U1); UHF-R (UR1); ULX Professional and ULX Standard (ULX1)	TA4F	Pin 1: Shield Shunt Pins 2-3 with R = 10k Ω Pin 3: Wire Pin 4: Not Connected
Telex	FMR Series 70, 500, 1000 (Transmitters WT-55, WT-500, WT-1000); SAFE 1000 (SAFE WT)	TA4F	Pin 1: Shield Pin 2: Wire Shunt Pins 2-3 with R = 10k Ω Pin 4: Not Connected

##### Frequency Response:

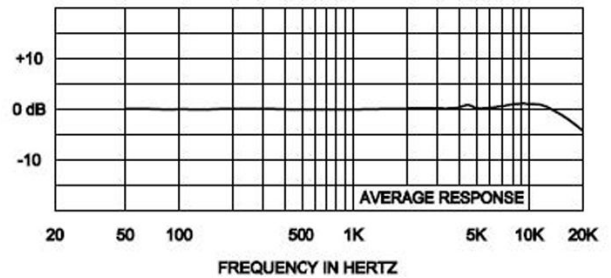

##### Polar Response:

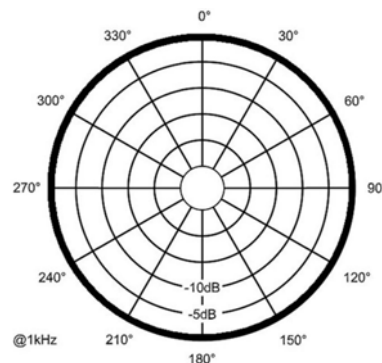

**Dimensions:**

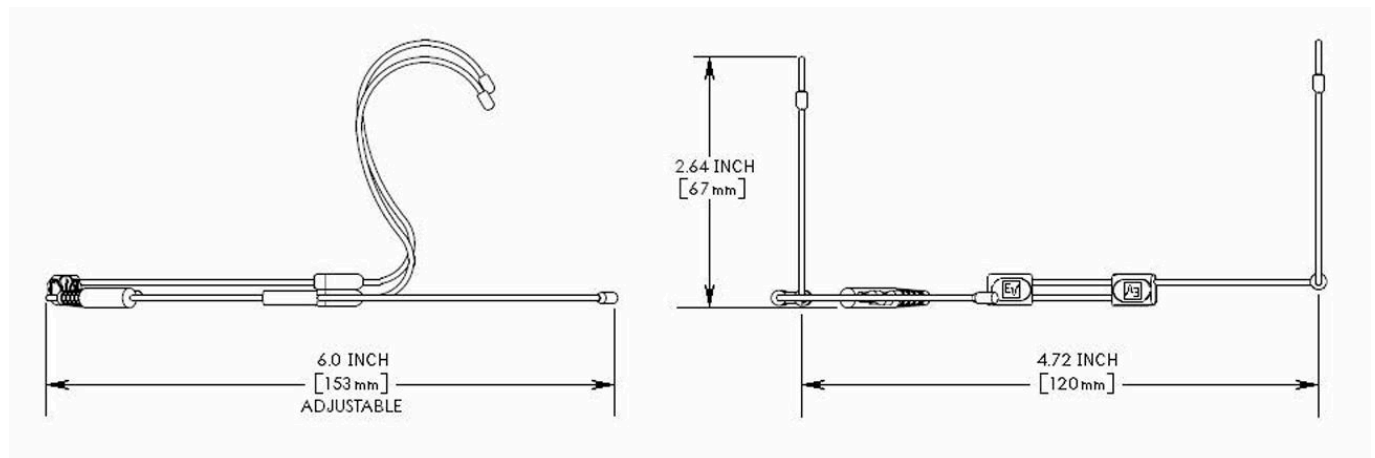

**Certifications and approvals**



**Ordering information**

**RE97-2TX BEIGE**  
Ultraminiature Condenser Headworn Mic, Omni, 2 Ear  
Version  
Order number **RE97-2-TX-BEIGE**

**Accessories**  
**TXA TA4 or XLR Lavalier and Headworn Microphone  
Adapter**  
TA4 to XLR Amplifier/Adapter -e.g.:  
RE920TX,RE97TX,HM7 direct to mixing console  
Order number **TXA**

**Represented by:**

**Americas:**  
Bosch Security Systems, Inc.  
12000 Portland Avenue South  
Burnsville MN 55337  
USA

[www.electrovoice.com](http://www.electrovoice.com)