

## PROLABS – JD121B-C

**10 Gigabit 1550nm SingleMode XFP Optical Transceiver, 40km Reach.**

### JD121B-C Overview

PROLABS's JD121B-C 10 GBd XFP optical transceivers are designed for the IEEE 802.3ae 10GBASE-ER, 10GBASE-EW, 10GFC and OC192 interconnects. The JD121B-C are compliant with the XFP Multi-Source Agreement (MSA) Specification. The Digital diagnostics functions are available via 2-wire serial interface, as specified in the XFP MSA.

### Product Features

- Up to 9.95 GBd to 11.3 GBd bit rates.
- Compliant with IEEE 802.3ae, 10GBASE-ER/EW, 10GFC, OC192 application.
- Compliant with XFP MSA.
- Temperature-stabilized 1550nm EML laser.
- 30 pin XFP compatible connector.
- Standard bail mechanism for consistent installation and removal
- Built-in digital diagnostic functions.
- Hot Pluggable XFP footprint.
- Duplex LC Connectors.
- 40km over SMF
- RoHS Compliance
- Class 1 laser product complies with EN 60825-1
- Operating temperature range: 0°C to 70°C.

### Applications

- 10GBASE-ER/EW 10G Ethernet
- 40Km 10G Fiber Channel
- OC192 IR-2 /STM S-64.2b

### Ordering Information

<i>Part Number</i>	<i>Description</i>
JD121B-C	OC-192/STM-64 IR 10GBASE-ER XFP, 1550nm, 40km over SMF. DOM

## Absolute Maximum Ratings

Parameter	Symbol	Min	Typ	Max	Unit	Remarks
Storage Ambient Temperature	$T_S$	-40		85	°C	
Supply Voltage 5V		-0.5		5.5		
Supply Voltage 3.3V	$V_{CC3}$	-0.5		4	V	

## General Specifications

Parameter	Symbol	Min	Typ	Max	Unit	Remarks
Data Rate	$DR$	9.95		11.3	GBd	
Bit Error Rate	$BER$			$10^{-12}$		
Total Power Consumption	$P$			3	W	
Supply Voltage - 5V	$V_{CC5}$	4.75		5.25	V	Operating Environment
Supply Voltage - 3.3V	$V_{CC3}$	3.13		3.45	V	Operating Environment
Supply Current - $V_{CC5}$ supply	$I_{CC5}$			200		
Supply Current - $V_{CC3}$ supply	$I_{CC3}$			500	mA	
Case Operating Temperature	$T_C$	0		70	°C	

## Link Distances

Parameter	Fiber Type	Distance Range (Km)
9.95 - 11.3 GBd	9/125um SMF	40

## Optical Characteristics - Transmitter

$V_{CC5}=4.75V$  to  $5.25V$ ,  $V_{CC3}=3.13V$  to  $3.45V$ ,  $T_C=0^\circ C$  to  $70^\circ C$

Parameter	Symbol	Min	Typ	Max	Unit	Remarks
Optical Wavelength	$\lambda$	1530		1580	nm	
Optical Power	$P_{OUT}$	-5		4	dBm	Average
Launch Power in OMA	$P_{OUT\_OMA}$	-1			dBm	
Launch Power of OFF Transmitter	$P_{OUT\_OFF}$			-30	dBm	Average
Side Mode Suppression Ratio	$SMSR$	30			dB	
Optical Extinction Ratio	$ER$	8.2			dB	
Relative Intensity Noise	$RIN$			-130	dB/Hz	
Transmitter Dispersion Penalty	$TDP$			2	dB	
Transmitter Jitter (Peak-to-Peak)	$T_j$			0.1	UI	

## Optical Characteristics - Receiver

$V_{CC5}=4.75V$  to  $5.25V$ ,  $V_{CC3}=3.13V$  to  $3.45V$ ,  $T_C=0^\circ C$  to  $70^\circ C$

Parameter	Symbol	Min	Typ	Max	Unit	Remarks
Center Wavelength Range	$\lambda_C$	1260		1600	nm	
Maximum Input Power	$P_{IN}$	0.5			dBm	
Receiver Sensitivity in OMA @ 10.3Gb/s	$P_{SENS1}$			-14.1	dBm	Measured with worst ER: $BER < 10^{-12}$ $2^{31-1}$ PRBS
Stressed Receiver Sensitivity in OMA @ 10.3Gb/s	$P_{SENS2}$			-11.3	dBm	IEEE 802.3ae
Receiver Reflectance	$TR_{RX}$			-27	dB	
LOS De-Assert	$LOS_D$			-20	dBm	
LOS Assert	$LOS_A$	-32			dBm	
LOS Hysteresis		0.5			dB	

## Electrical Characteristics – Transmitter

$V_{CC_5}=4.75V$  to  $5.25V$ ,  $V_{CC_3}=3.13V$  to  $3.45V$ ,  $T_C=0^\circ C$  to  $70^\circ C$

Parameter	Symbol	Min	Typ	Max	Unit	Remarks
Input differential impedance	$R_{in}$		100		$\Omega$	After internal AC coupling
Differential data input swing	$V_{IN\_PP}$	120		820	mV	
Transmit Disable Voltage	$V_D$	2		$V_{CC}$	V	Or open circuit
Transmit Enable Voltage	$V_{EN}$	GND		GND+0.8	V	
Transmit Disable Assert Time				10	us	

## Electrical Characteristics – Receiver

$V_{CC_5}=4.75V$  to  $5.25V$ ,  $V_{CC_3}=3.13V$  to  $3.45V$ ,  $T_C=0^\circ C$  to  $70^\circ C$

Parameter	Symbol	Min	Typ	Max	Unit	Remarks
Differential data output swing	$V_{OUT\_PP}$	340	650	850	mV	
Data output rise time	$T_R$			38	ps	20%-80%
Data output fall time	$T_F$			38	ps	20%-80%
LOS Fault	$V_{LOS\_F}$	$V_{CC}-0.5$		$V_{CC\_HOST}$	V	
LOS Normal	$V_{LOS\_N}$	GND		GND+0.5	V	

## Digital Diagnostic

PROLABS's JD121B-C incorporates a XFP compliant 2-wire management interface which is used for serial ID, digital diagnostics, and certain control functions. It is modeled on the SFF-8472 Rev 9.3 specification modified to accommodate a single 2-wire interface address. In addition to the basic I<sup>2</sup>C read/write functionality the modules support packet error checking that, when enabled, allows the host system to confirm the validity of any read data. Details of the protocol and interface are explicitly described in the MSA. And the digital diagnostic functions via a 2-wire serial interface can provide real-time access to following operating parameters:

- a. Transceiver Temperature
- b. Laser Bias Current
- c. Transmitted Optical Power
- d. Received Optical Power
- e. Transceiver Supply Voltage

## Block Diagram

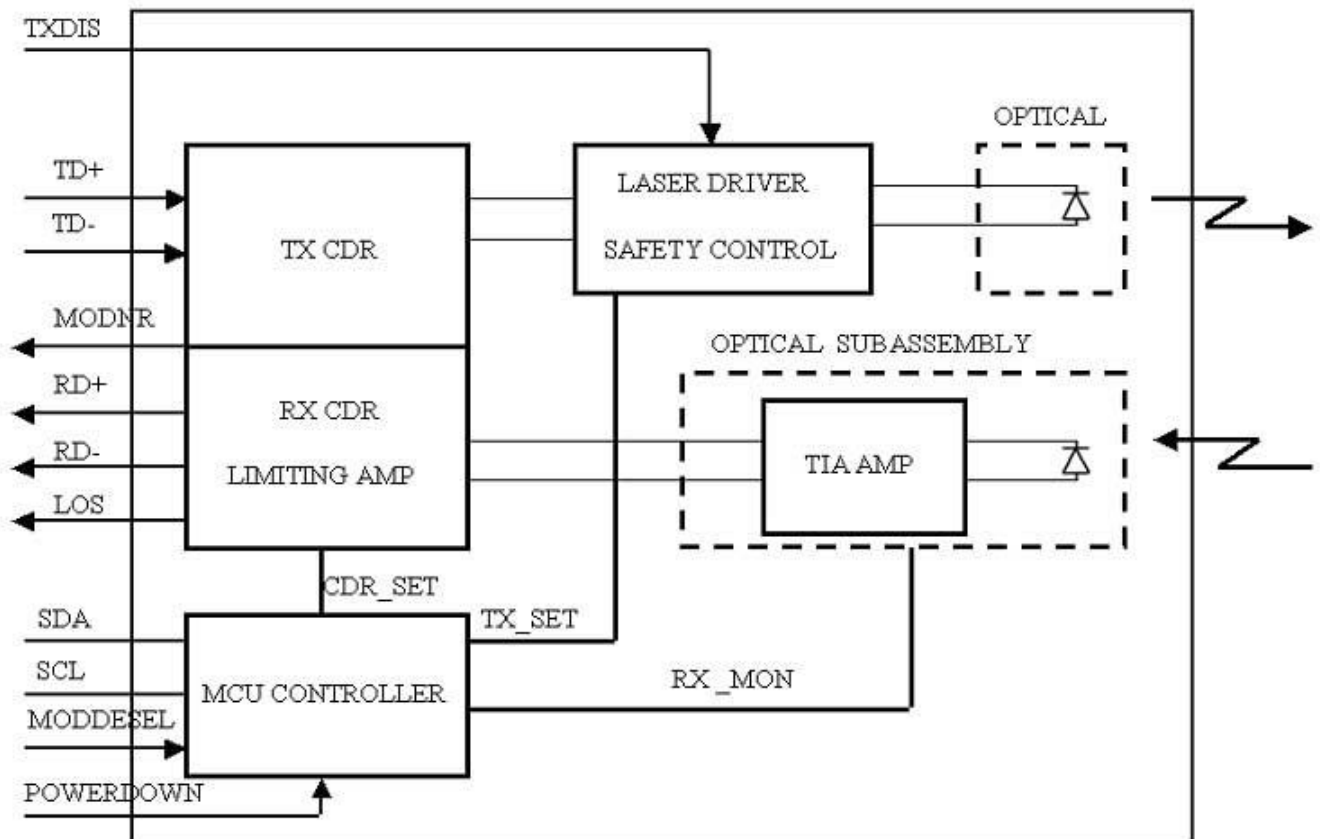

### Transmitter Section:

The Laser Driver accept differential input data and provide bias and modulation currents for driving a laser. An automatic power control (APC) feedback loop is incorporated to maintain a constant average optical power. Laser in an eye safe optical subassembly (OSA) mates to the fiber cable. TX CDR is used to overcomes host board and connector signal degradations by reshaping, regenerating, and attenuating jitter.

### TXDIS:

TX\_DIS is a input pin. When TX\_DIS is asserted High, the XFP module transmitter output must be turned off.

### Receiver Section:

The Receiver utilizes a PIN detector integrated with a trans-impedance preamplifier in an OSA. The OSA is connected to a limiting Amplifier which providing post-amplification quantization, and optical signal detection. The limiting amplifier is AC coupled to the Trans-impedance amplifier , with internal 100ohm differential termination. RX CDR is used to overcomes host board degradations by reshaping, regenerating, and attenuating jitter.

### LOS:

The LOS of an output pin , when LOS is high, it indicates insufficient optical power for reliable signal reception.

### MODNR:

The MODNR is an output pin that when High, indicates that the module has detected a condition that renders transmitter and or receiver data invalid, shall consist of logical OR of the following signals:

- Transmit Signal Conditioner Loss of Lock
- Transmitter Laser Fault
- Receiver Signal Conditioner Loss of Lock

### Controller Section

The micro controller unit initializes the control register of laser driver, limiting amplifier and CDR. And monitors the running information from the laser driver, limiting amplifier and CDR. Then report these information to the customer.

## Dimensions

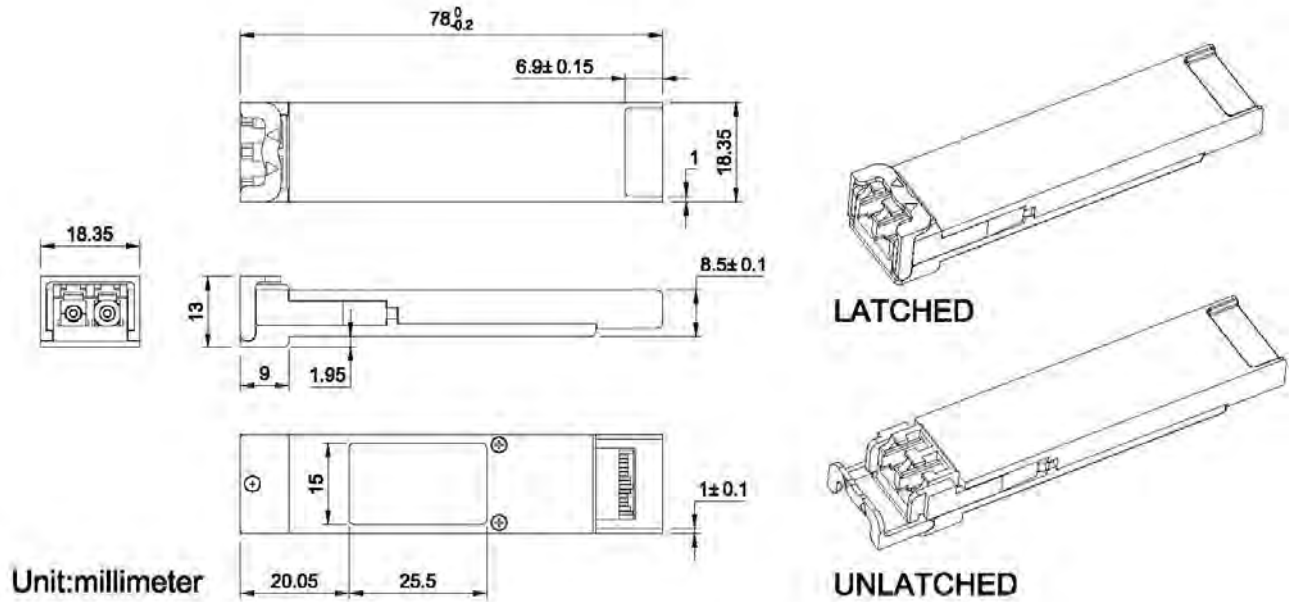

**ALL DIMENSIONS ARE  $\pm 0.2$ mm UNLESS OTHERWISE SPECIFIED**



## Pin Assignment – Pin 1 to Pin 23

<b>PIN #</b>	<b>Symbol</b>	<b>Logic</b>	<b>Description</b>	<b>Remarks</b>
1	GND		Module Ground	Module ground pins (GND) are isolated from the module case and chassis ground within the module
2	VEE5		Optional – 5.2 Power Supply (Not required)	
3	Mod-Desel	LVTTTL-I	Module De-select, when held low allows the module to respond to 2-wire serial interface commands	
4	Interrupt	LVTTTL-O	Indicates presence of an important condition which can be read over the serial 2-wire interface	Open collector, should be pulled up with 4.7k $\Omega$ -10k $\Omega$ on host board to a voltage between 3.15V and 3.6V
5	TX_DIS	LVTTTL-I	Transmitter Disable, Transmitter laser source turned off	
6	VCC5		+5V Power Supply	
7	GND		Module Ground	Same as Pin# 1
8	VCC3		+3.3V Power Supply	
9	VCC3		+3.3V Power Supply	
10	SCL	LVTTTL-I	Serial 2-wire interface clock	Same as Pin# 4
11	SDA	LVTTTL-I/O	Serial 2-wire interface data line	Same as Pin# 4
12	Mod_Abs	LVTTTL-O	Module Absent, Indicates module is not present. Grounded in the module	Same as Pin# 4
13	Mod_NR	LVTTTL-O	Module Not Ready, Indicates Module operating fault	Same as Pin# 4
14	RX_LOS	LVTTTL-O	Receiver Loss of Signal indicator	Same as Pin# 4
15	GND		Module Ground	Same as Pin# 1
16	GND		Module Ground	Same as Pin# 1
17	RD-	CML-O	Receiver inverted data output	
18	RD+	CML-O	Receiver non-inverted data output	
19	GND		Module Ground	Same as Pin# 1
20	VCC2		+1.8V Power Supply	
21	P_Down/RST	LVTTTL-I	Power Down, When high, places the module in the low power stand-by mode and on the falling edge of P_Down initiates a module rest Reset, The falling edge initiates a complete reset of the module including the 2-wire serial interface, equivalent to a power cycle	
22	VCC2		+1.8V Power Supply	
23	GND		Module Ground	Same as Pin# 1

## Pin Assignment – Pin 24 to Pin 30

<i><b>PIN #</b></i>	<i><b>Symbol</b></i>	<i><b>Logic</b></i>	<i><b>Description</b></i>	<i><b>Remarks</b></i>
24	RefCLK+	PECL-I	Reference Clock non-inverted input, AC coupled on the host board	
25	RefCLK-	PECL-I	Reference Clock inverted input, AC coupled on the host board	
26	GND		Module Ground	Same as Pin# 1
27	GND		Module Ground	Same as Pin# 1
28	TD-	CML-I	Transmitter inverted data input	
29	TD+	CML-I	Transmitter non-inverted data input	
30	GND		Module Ground	Same as Pin# 1

## Electrical Pad Layout

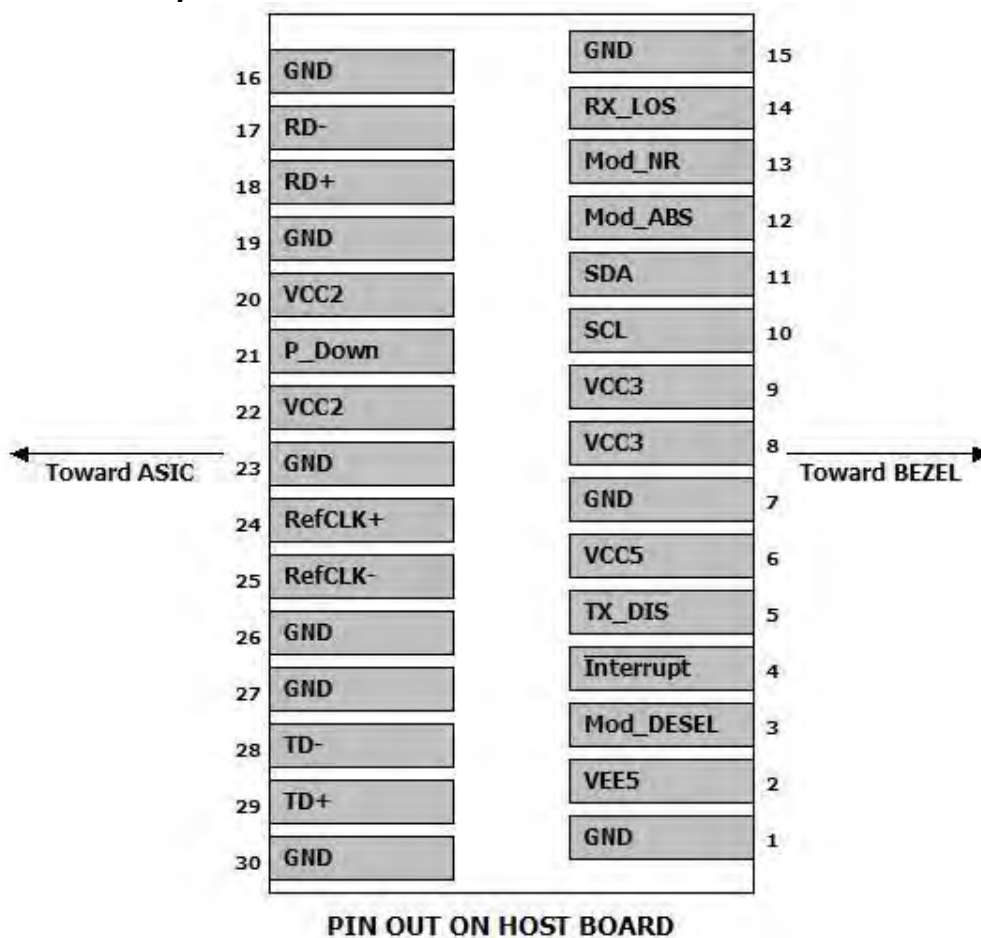

## References

1. 10 Gigabit Small Form Factor Pluggable Module (XFP) Multi-Source Agreement (MSA), Rev 4.5 – August 2005.