

PROLABS – 3CSFP81-C

125 MBd Fast Ethernet SFP (Small Form Pluggable) MultiMode Transceiver

3CSFP81-C Overview

PROLABS's 3CSFP81-C Fast Ethernet SFP optical transceivers are comply with Fast Ethernet standards at 125MBd data rate. They comply with the Small Form Factor Pluggable Multi Sourcing Agreement (MSA).

Product Features

- Up to 125MBd bi-directional data links
- Compliant with 100BASE-FX
- Compliant with SFP MSA
- Hot-pluggable SFP footprint
- 1310nm LED transmitter
- Duplex LC connector
- Up to 2km on MMF
- Single power supply 3.3V
- RoHS Compliance
- Class 1 laser product complies with EN 60825-1
- Operating temperature range: 0°C to 70°C.

Applications

- 125MBd Fast Ethernet

Ordering Information

<i>Part Number</i>	<i>Description</i>
3CSFP81-C	Fast Ethernet SFP LC Connectors 1310nm MultiMode 2KM

General Specifications

<i>Parameter</i>	<i>Symbol</i>	<i>Min</i>	<i>Typ</i>	<i>Max</i>	<i>Unit</i>	<i>Remarks</i>
Data Rate	<i>DR</i>		125		MBd	Fast Ethernet
Bit Error Rate	<i>BER</i>			10^{-12}		
Operating Temperature	<i>T_{OP}</i>	0		70	°C	Case temperature
Storage Temperature	<i>T_{STO}</i>	- 40		85	°C	Ambient temperature
Supply Current	<i>I_S</i>		165	300	mA	For electrical power interface
Input Voltage	<i>V_{CC}</i>	3	3.3	3.6	V	
Maximum Voltage	<i>V_{MAX}</i>	- 0.5		4.5	V	For electrical power interface

Optical Characteristics – Transmitter

$V_{CC}=3V$ to $3.6V$, $T_c=0^\circ C$ to $70^\circ C$

<i>Parameter</i>	<i>Symbol</i>	<i>Min</i>	<i>Typ</i>	<i>Max</i>	<i>Unit</i>	<i>Remarks</i>
Output Optical Power @ 62.5um MMF	P_{OUT_1}	- 20		- 14	dBm	
Output Optical Power @ 50um MMF	P_{OUT_2}	- 23.5		- 14	dBm	
Optical Center Wavelength	λ_C	1280		1380	nm	
Extinction Ratio	ER	10			dB	
Spectral Width (FWHM)	$\Delta\lambda$			175	nm	Specified to meet curves in FDDI PMD ³ Figure 9, which allow trade-off between wavelength, spectral width and transmitter rise/fall times
Optical Rise/Fall Time (20% - 80%)	T_{RF_IN}		1000	3000	ps	
Relative Intensity Noise	RIN			- 120	dB/Hz	
Generated Jitter (peak to peak)	GJ_{PP}			0.07	UI	
Generated Jitter (rms)	GJ_{RMS}			0.007	UI	
Random Jitter Contribution	$TX\Delta RJ$			0.76	ns	

Optical Characteristics – Receiver

$V_{CC}=3V$ to $3.6V$, $T_C=0^\circ C$ to $70^\circ C$

<i>Parameter</i>	<i>Symbol</i>	<i>Min</i>	<i>Typ</i>	<i>Max</i>	<i>Unit</i>	<i>Remarks</i>
Optical Receiver Power	P_{RX}			- 14	dBm	BER < 10^{-12}
Optical Center Wavelength	λ_C	1270		1600	nm	
Receiver Sensitivity @ FE	R_{SEN1}			- 31	dBm	PRBS $2^{23}-1$
Optical Return Loss	ORL	12			dB	
Receiver Electrical 3dB Upper cutoff frequency				1500	MHz	
Loss of Signal-Asserted	P_{LOS_A}	- 45			dBm	
Loss of Signal-Deasserted	P_{LOS_D}			- 33	dBm	
Loss of Signal-Hysteresis		1.5			dB	

Electrical Characteristics – Transmitter

$V_{CC}=3V$ to $3.6V$, $T_C=0^\circ C$ to $70^\circ C$

<i>Parameter</i>	<i>Symbol</i>	<i>Min</i>	<i>Typ</i>	<i>Max</i>	<i>Unit</i>	<i>Remarks</i>
Input differential impedance	R_{IN}		100		Ω	Non condensing
Single ended data input swing	V_{IN_PP}	250		1200	mV	
Transmit disable voltage	V_D	2		V_{CC}	V	
Transmit enable voltage	V_{EN}	V_{EE}		$V_{EE}+0.8$	V	
Transmit disable assert time				10	us	

Electrical Characteristics – Receiver

$V_{CC}=3V$ to $3.5V$, $T_C=0^\circ C$ to $70^\circ C$

<i>Parameter</i>	<i>Symbol</i>	<i>Min</i>	<i>Typ</i>	<i>Max</i>	<i>Unit</i>	<i>Remarks</i>
Single ended data output swing	V_{OUT_PP}	250	450	900	mV	
Data output rise/fall time (10%-90%)	$T_{R/F}$	0.6		5	ns	
LOS Fault	V_{LOS_Fault}	2		V_{CC_HO}	V	
LOS Normal	V_{LOS_normal}	V_{EE}		$V_{EE}+0.5$	V	

Block Diagram of Transceiver

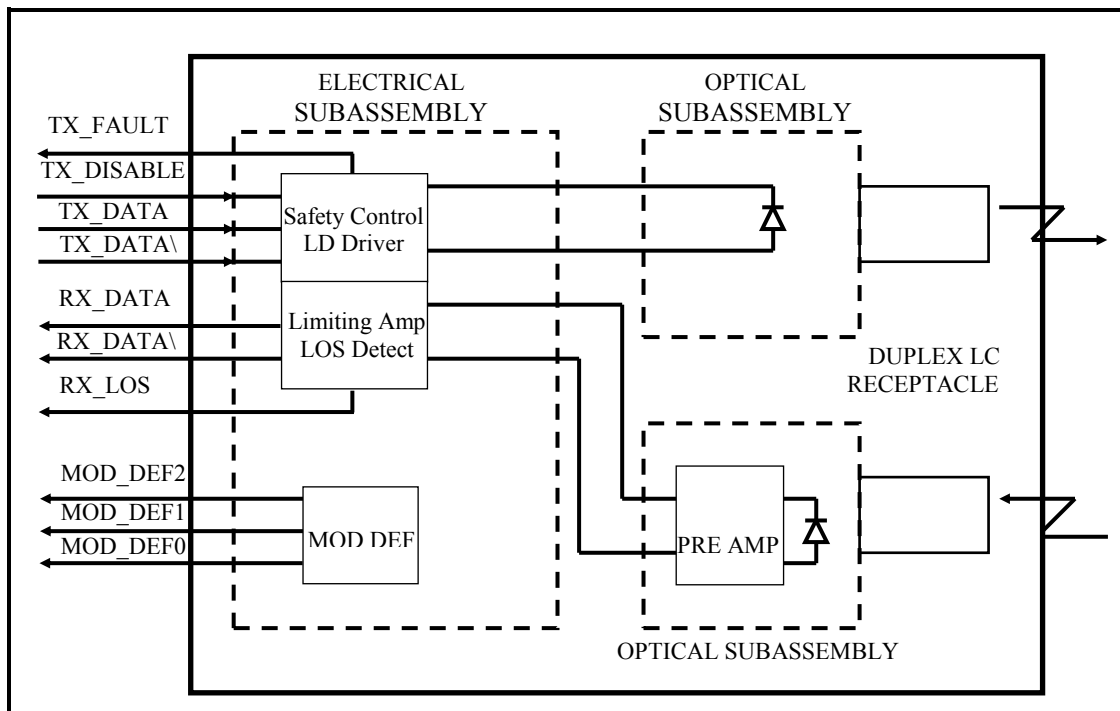

Transmitter Section

The laser driver accept differential input data and provide bias and modulation currents for driving a laser. An automatic power-control (APC) feedback loop is incorporated to maintain a constant average optical power. 1310 nm LED in an eye safe optical subassembly (OSA) mates to the fiber cable.

TX_DISABLE

The TX_DISABLE signal is high (TTL logic "1") to turn off the laser output. The laser will turn on within 1ms when TX_DISABLE is low (TTL logic "0").

TX_FAULT

When the TX_FAULT signal is high, output indicates a laser fault of some kind. Low indicates normal operation.

Receiver Section

The receiver utilizes a PIN detector integrated with a trans-impedance preamplifier in an OSA. This OSA is connected to a Limiting Amplifier which providing post-amplification quantization, and optical signal detection. The limiting Amplifier is AC-coupled to the transimpedance amplifier, with internal 100Ω differential termination.

Receive Loss (RX_LOS)

The RX_LOS is high (logic "1") when there is no incoming light from the companion transceiver. This signal is normally used by the system for the diagnostic purpose. The signal is operated in TTL level.

Dimensions

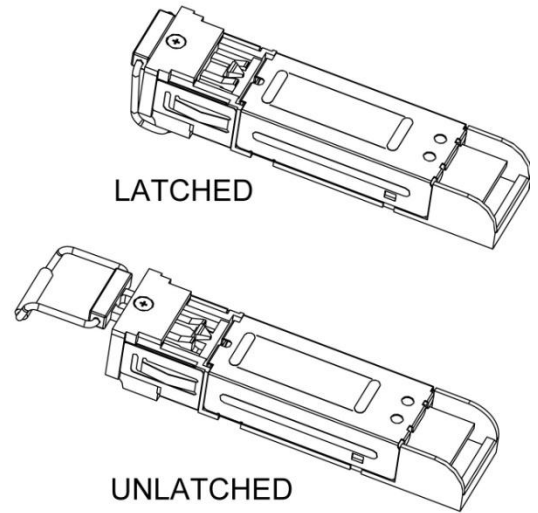
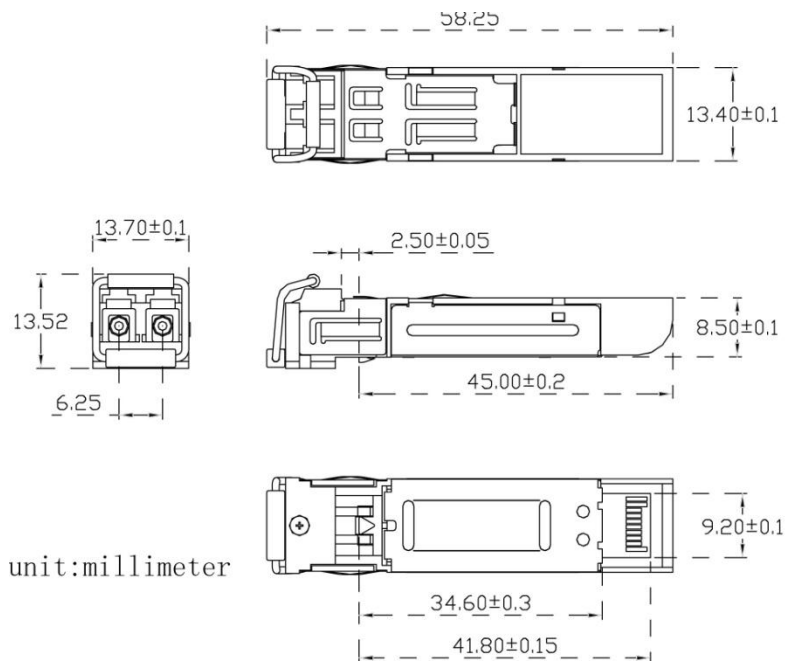

**ALL DIMENSIONS ARE ± 0.2 mm UNLESS OTHERWISE SPECIFIED
UNIT: mm**

PCB Layout Recommendation

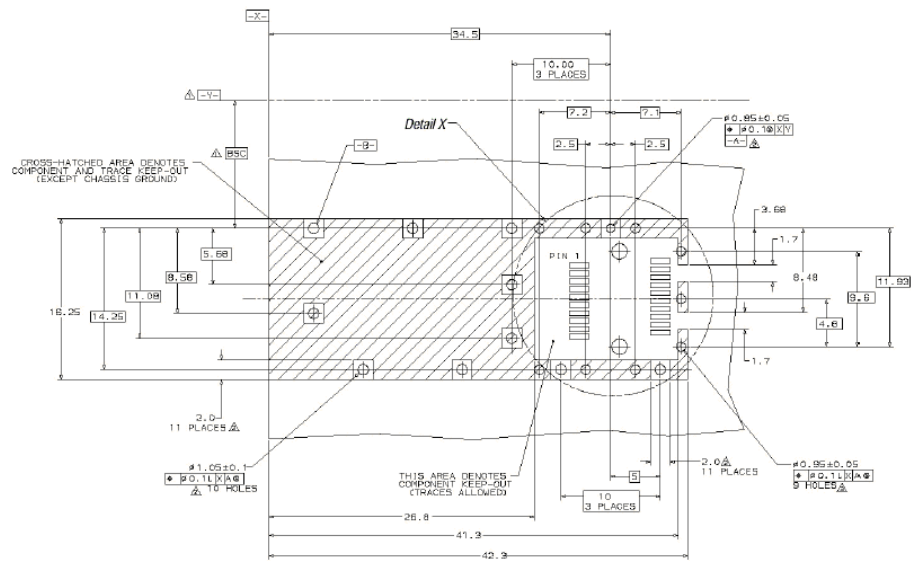

△ Datum and Basic Dimension Established by Customer

△ Rads and Vias are Chassis Ground, 11 Places

△ Through Holes are Unplated

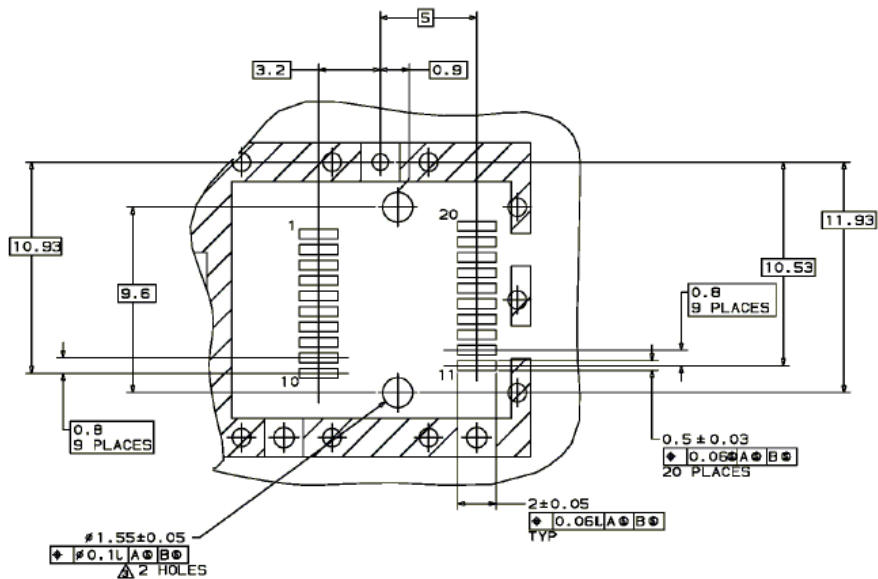

Electrical Pad Layout

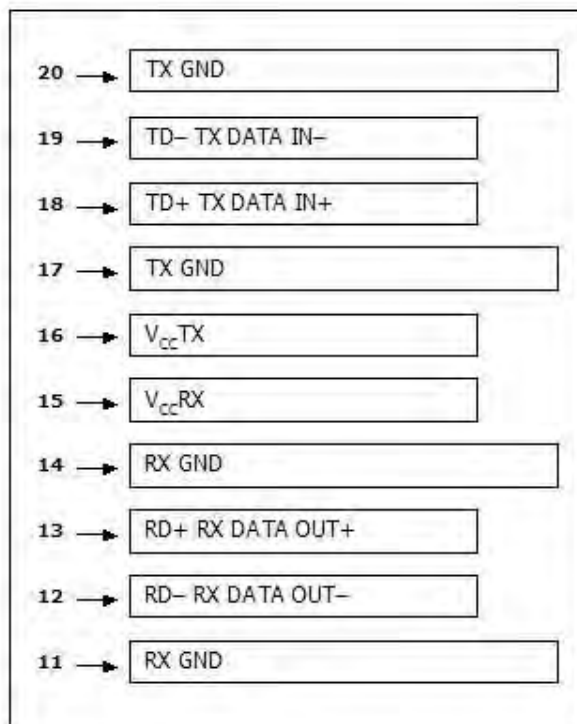
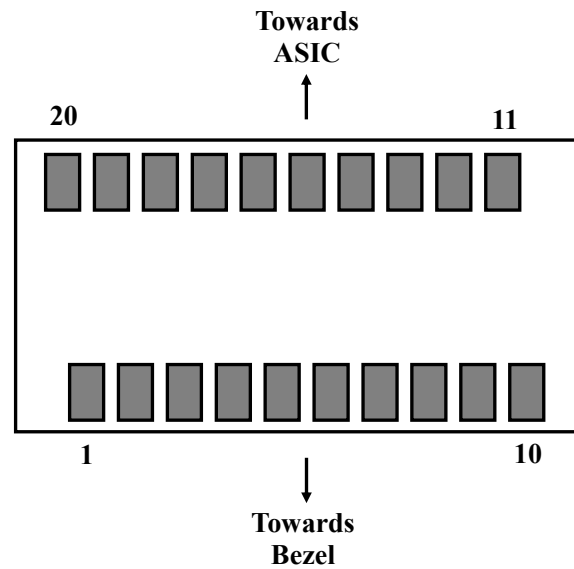

Top of Board

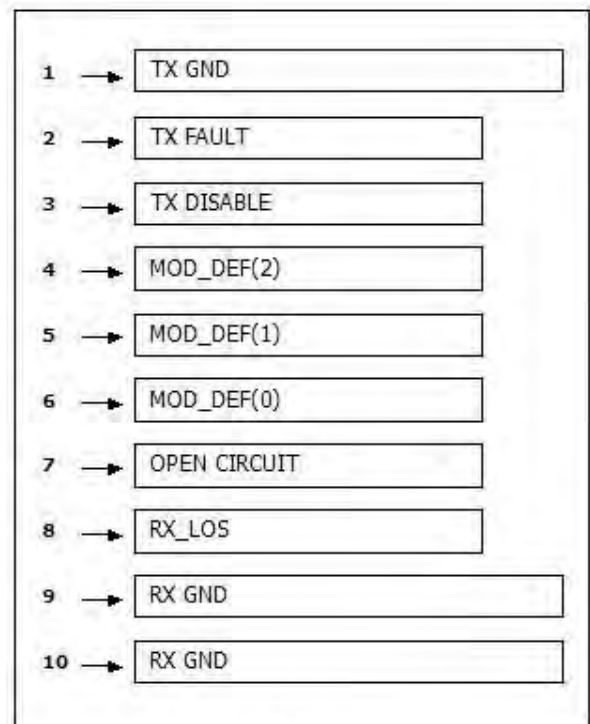

Bottom of Board

Pin Assignment

PIN #	Symbol	Description	Remarks
1	V_{EET}	Transmitter ground (common with receiver ground)	Circuit ground is isolated from chassis ground
2	T_{FAULT}	Transmitter Fault. Not supported	
3	T_{DIS}	Transmitter Disable. Laser output disable on high or open	Disabled: $T_{DIS} > 2V$ or open Enabled: $T_{DIS} < 0.8V$
4	MOD_DEF (2)	Module Definition 2. Data line for serial ID	Should Be pulled up with 4.7k – 10k ohm on host board to a voltage between 2V and 3.6V
5	MOD_DEF (1)	Module Definition 1. Clock line for serial ID	
6	MOD_DEF (0)	Module Definition 0. Grounded within the module	
7	Rate Select	No connection required	
8	LOS	Loss of Signal indication. Logic 0 indicates normal operation	LOS is open collector output
9	V_{EER}	Receiver ground (common with transmitter ground)	Circuit ground is isolated from chassis ground
10	V_{EER}	Receiver ground (common with transmitter ground)	
11	V_{EER}	Receiver ground (common with transmitter ground)	
12	RD-	Receiver Inverted DATA out. AC coupled	
13	RD+	Receiver Non-inverted DATA out. AC coupled	
14	V_{EER}	Receiver ground (common with transmitter ground)	Circuit ground is isolated from chassis ground
15	V_{CCR}	Receiver power supply	
16	V_{CCT}	Transmitter power supply	
17	V_{EET}	Transmitter ground (common with receiver ground)	Circuit ground is connected to chassis ground
18	TD+	Transmitter Non-Inverted DATA in. AC coupled	
19	TD-	Transmitter Inverted DATA in. AC coupled	
20	V_{EET}	Transmitter ground (common with receiver ground)	Circuit ground is connected to chassis ground

References

1. Small Form Factor Pluggable (SFP) Transceiver Multi-Source Agreement (MSA), September 2000.
2. ISO/IEC 9314-3 "Information Processing Systems – fiber Distributed Data Interface (FDDI), Part 3, Physical Layer Medium Dependent (PMD)." 1990.