

NOTICE OF PROPRIETARY RIGHTS THIS DOCUMENT CONTAINS CONFIDENTIAL TECHNICAL DATA, INCLUDING TRADE SECRETS, PROPRIETARY TO TIMES MICROWAVE SYSTEMS. DISCLOSURE OF THIS DATA IS EXPRESSLY CONDITIONED UPON YOUR ASSENT THAT ITS USE IS LIMITED TO USE WITHIN YOUR COMPANY ONLY. ANY OTHER USE IS STRICTLY PROHIBITED WITHOUT THE PRIOR WRITTEN CONSENT OF TIMES MICROWAVE SYSTEMS.

SYM	REVISION DESCRIPTION	DFTM	DATE	APPD	DATE
A	RELEASED FOR PRODUCTION	D. J. H.	6/13/11	J. D. B.	6/27/11
B	CHANGED PER CDC #33920	D. J. H.	8/12/11	J. D. B.	8/15/11

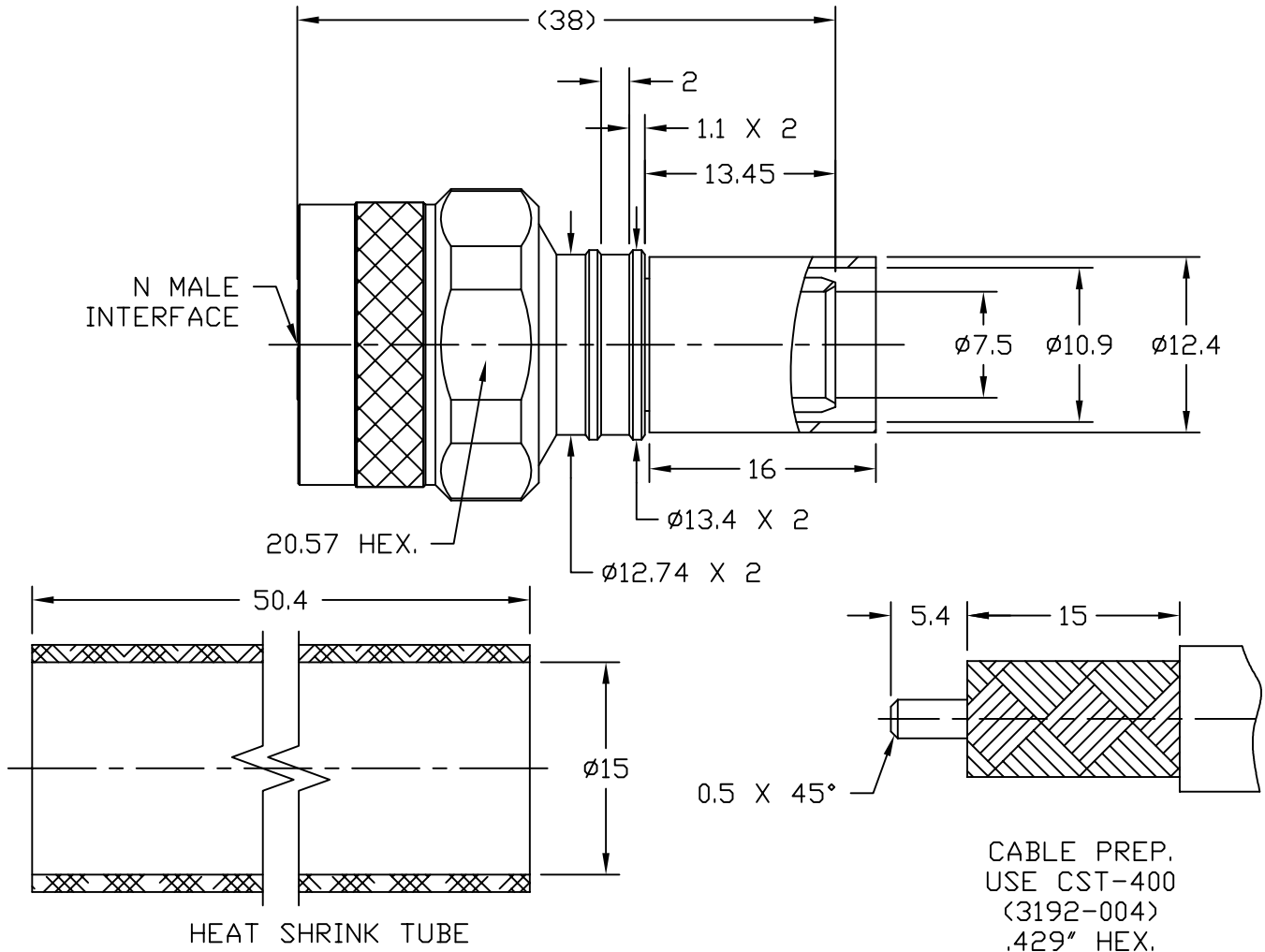

Reference standard	IEC60169-16	III. Material and plating:	
I. Electric Performance		Component	Material
Impedance(Ω):	50	inner conductor	Brass
Frequency Range:	DC-6GHz	outer conductor	Brass
VSWR:	≤1.25	tube	Copper
Insert Loss: (dB)	≤ 0.05	nut	Brass
Insulation resistance (MΩ)	>5000	gasket	Silicone rubber
Work voltage (V)	1500	insulator	PTFE
Conductor resistance (mΩ)	outer conductor <0.2 inner conductor <0.8	IV. Environment	
II. Mechanical Performance		Temp.range	-55°C~+155°C
Nut torque	25N.m	Weather standard	IEC 60068 55 / 155/ 56
(Nut) Whorl pull	1000N	Thermal shock	US MIL-STD 202,Meth.107,Cond.B
Tensile force(cable-connect)	400N	Vibration	US MIL-STD 202,Meth.204,Cond.B
Torsion(cable-connect)	2N.m	Shock	US MIL-STD 202,Meth.213,Cond.I
		Waterproofing standard IP67	

V. Assembly: inner conductor installed and outer conductor crimped

MATERIAL:	UNLESS OTHERWISE SPECIFIED	DFTM. D. J. H.	TIMES MICROWAVE SYSTEMS				
		DATE 6/13/11					
USED ON: 0	ALL DIMENSIONS ARE IN mm MACHINED SURFACES FINISH N/A RMS MAX. REMOVE ALL BURRS N/A MAX. BREAK MACHINE CORNERS N/A MAX. FILLET R. TOLERANCES ON DECIMALS . XX ± N/A . XXX ± N/A ANGLES ± 1° FRACTIONS ± N/A	CHKD. J. D. B.	EZ-400-NMH-X "N" MALE FOR LMR-400 CABLE EZ/CRIMP/NO BRAID TRIM				
		DATE 6/27/11					
		APPD. J. D. B.					
SCALE: N/A	DWG. SIZE A	DO NOT SCALE DRAWING	CODE IDENT 68999	DATE 6/27/11	SHEET 1 of 1	SD3190-2590	REV B