

MODEL:

# SRW15US

## SmartRack® Wall-Mount Rack Enclosure Cabinet



15 Rack Units



225 lb. Load Rating



Sturdy Steel Construction



Locking Doors & Side Panels



Accommodates Standard 19-inch Equipment



Convenient Cable Access



Adjustable Mounting Rails



Hinged Wall Bracket



Ventilated for Ample Airflow



Reversible Cabinet



Square Hole Mounting

- A** Front Door (Lockable/Removable/Reversible)
- B** Adjustable Mounting Rails (4)
- C** Side Panels (2) (Lockable/Removable)
- D** Hinged Wall Bracket (Lockable/Reversible. Allows the cabinet to swing away from the wall for convenient rear access to equipment and cabling.)
- E** Cable Access Port Covers (4) (Removable)
- F** Ventilation Fan Ports (4) (Support optional SRFANWM fan kit.)
- G** Keys (2)

Also Includes: Owner's Manual, mounting plate screws (3), cabinet ground screw, pre-installed front door ground wire and rackmount equipment mounting hardware (42 cage nuts, 42 mounting screws, 42 nylon cup washers).

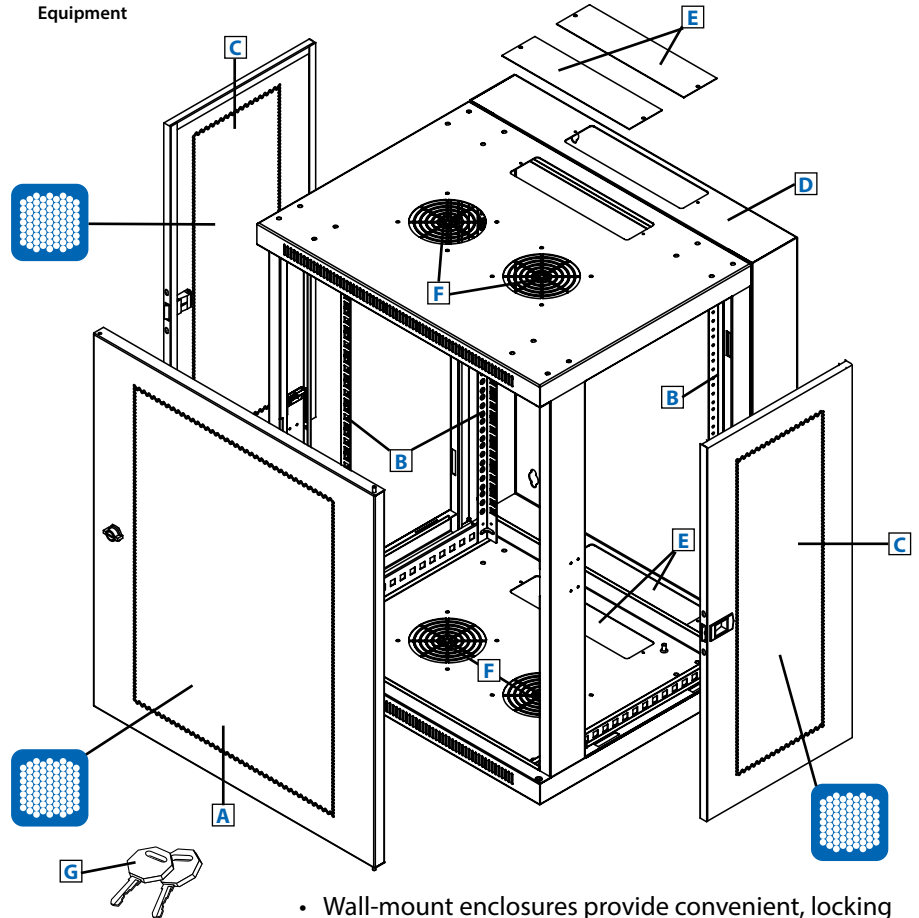

- Wall-mount enclosures provide convenient, locking storage for rackmount IT devices and other equipment that should be off the floor, out of the way and secure
- The cabinet is fully reversible, allowing installers to change door hinges from left to right by simply rotating the unit 180 degrees before mounting
- Hinged wall bracket allows cabinet to swing away from the wall for convenient access to equipment and cabling

**SEE NEXT PAGE FOR DETAILED UNIT MEASUREMENTS**



1111 W. 35th Street  
Chicago, IL 60609 USA  
773.869.1234  
www.tripplite.com

### Specifications

Model	SRW15US
Rack Spaces	15U
Equipment Mounting Depth	Up to 20.5 in. (520.7 mm)
Load Rating*	225 lb. (102 kg)
Unit Dimensions (H x W x D)	30.33 x 23.63 x 21.6 in. (770 x 600 x 549 mm)
Shipping Dimensions (H x W x D)	33.07 x 26.38 x 24.41 in. (840 x 670 x 620 mm)
Unit Weight	88.2 lb. (40 kg)
Shipping Weight	96 lb. (43.5 kg)
Standards	Meets EIA-310-D, IEC 60297-3-100, NOM, DIN 41494, RoHS and PCI-DSS standards; IP20 Protection Rating

\* The load rating includes the combined weight of the unit and installed equipment. The unit must be mounted to a stable surface with user-supplied anchors capable of bearing the full load. Tripp Lite has a policy of continuous improvement. Specifications are subject to change without notice.



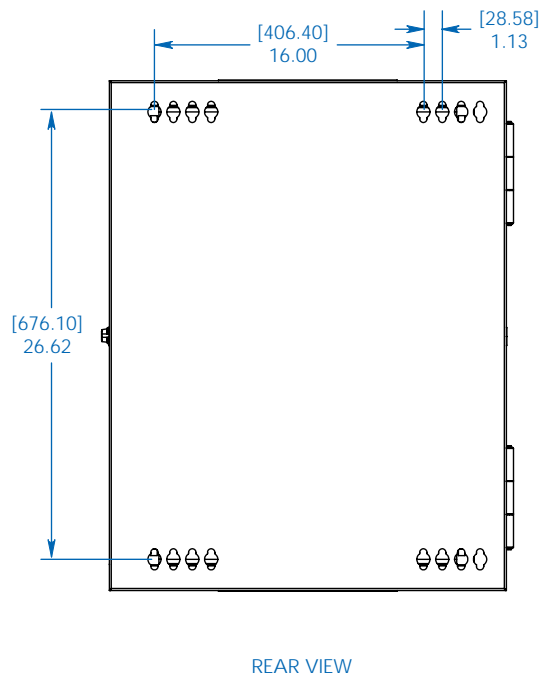
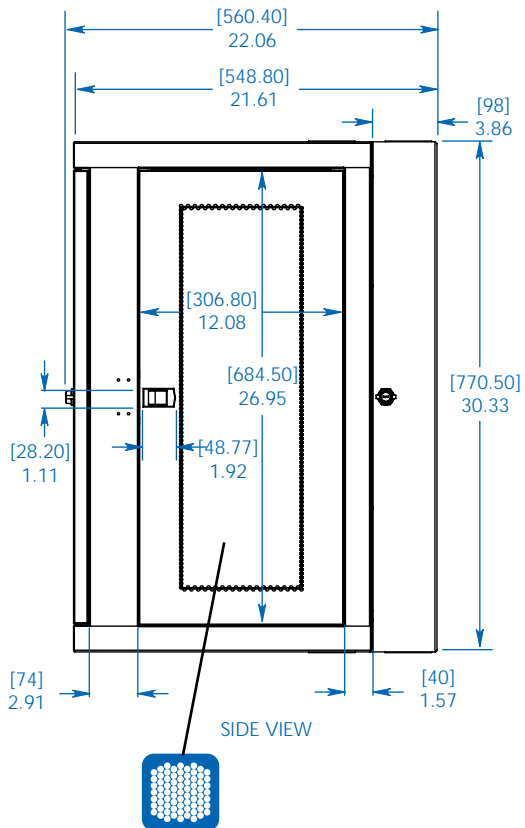
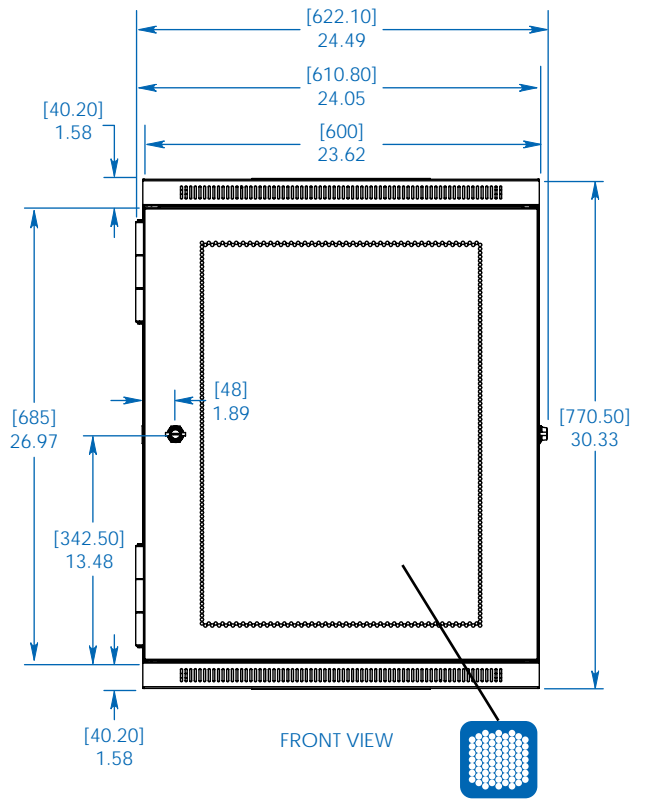
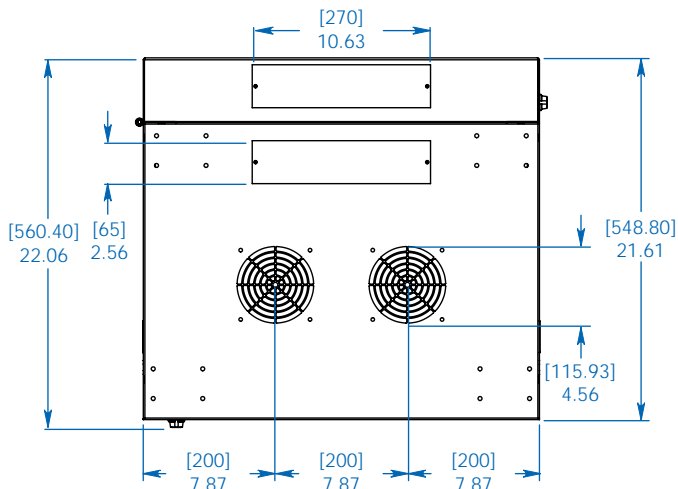

Dimensions: [mm] INCHES

Tripp Lite has a policy of continuous improvement. Specifications are subject to change without notice.

MODEL:  
**SRW15US**  
**TRIPP·LITE**

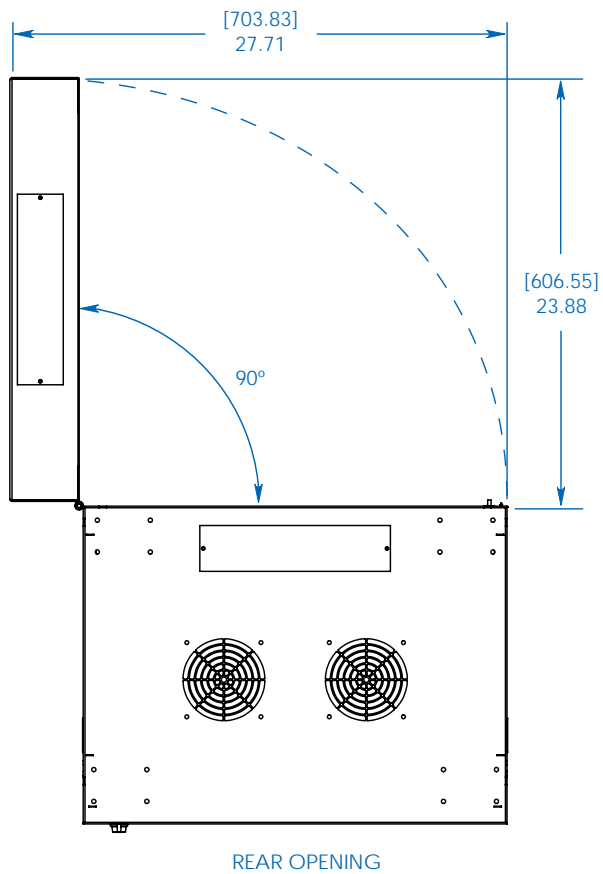
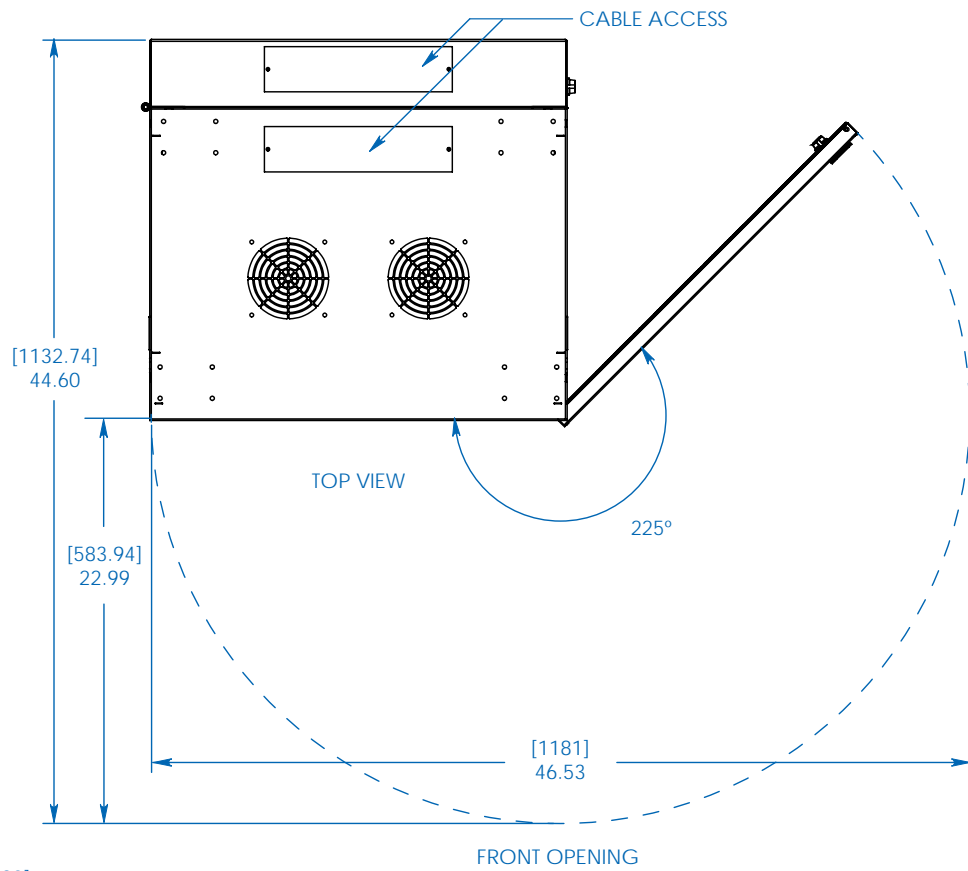

Dimensions: [mm] INCHES

Tripp Lite has a policy of continuous improvement. Specifications are subject to change without notice.

MODEL:  
**SRW15US**

**TRIPPLITE**

1111 W. 35th Street  
Chicago, IL 60609 USA  
773.869.1234  
www.tripplite.com