

MODEL:

SR42UBEXPND

SmartRack™ Premium Rack Enclosure



42 Rack Units



3000 lb
Stationary
Load Capacity



2250 lb
Rolling
Load Capacity



Heavy-Duty
Casters



Standard 19-inch
Rack Width



Toolless
Mounting Slots



Adjustable
Rails with Easy-View
Depth Index



Integrated
Baying Tabs



Square Hole
Mounting

- A** Adjustable Mounting Rails (4)
- B** Adjustable PDU Mounting Rails with Toolless Mounting Slots (2 rails hold up to 4 vertical PDUs.)
- C** Roof Panel (Removable)
- D** Rolling Casters (4)
- E** Levelers (4)

Also Includes: Owner's Manual, 2 shipping/stabilizing brackets and rackmount equipment mounting hardware (50 cage nuts, 50 mounting screws, 50 nylon cup washers).

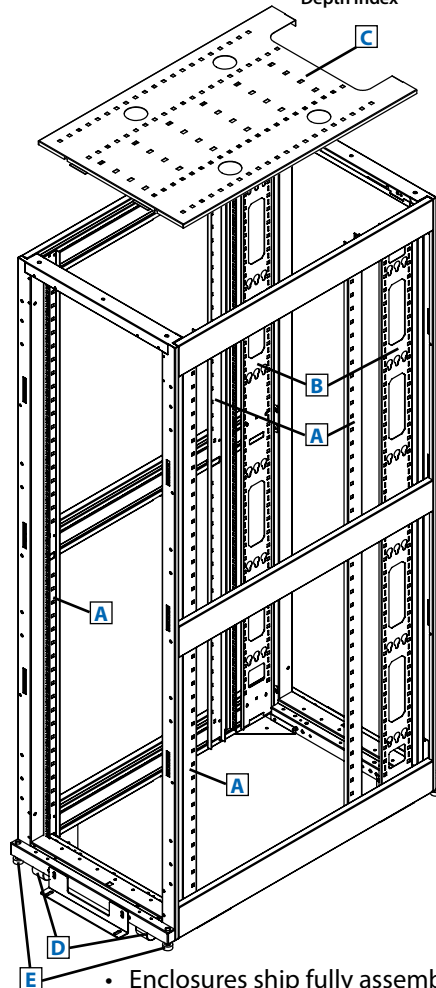

Specifications

Model	SR42UBEXPND
Rack Spaces	42U
Stationary Load Capacity	3000 lb (1363 kg)
Rolling Load Capacity	2250 lb (1022 kg)
Unit Dimensions (H x W x D)	78.5 x 23.63 x 43 in. (1994 x 600 x 1092 mm)
Shipping Dimensions (H x W x D)	84.5 x 27.75 x 47 in. (2146 x 705 x 1194 mm)
Unit Weight	142 lb (64.4 kg)
Shipping Weight	165 lb (74.8 kg)
Certifications	UL 60950, RoHS, CE, NOM (Mexico), IEC 60297-3-100, DIN 41494, EIA/ECA-310-E Compliant (Accommodates all standard 19-inch rackmount equipment regardless of vendor.)

Tripp Lite has a policy of continuous improvement. Specifications are subject to change without notice.

- Enclosures ship fully assembled for rapid deployment, but can be knocked down for easy reassembly in confined spaces
- Modular design optimized for quick configuration and reconfiguration
- Ideal for rackmount server, network and telecom applications

SEE NEXT PAGE FOR DETAILED UNIT MEASUREMENTS



1111 W. 35th Street
Chicago, IL 60609 USA
773.869.1234
www.tripplite.com

Also Available: Shock pallet models with special packaging to facilitate equipment pre-installation and reshipment to final site. Heavy-duty shock pallet holds up to 1250 lb (568 kg), including the weight of the enclosure and pre-installed equipment. Add "SP1" to model numbers above to order shock pallet models.

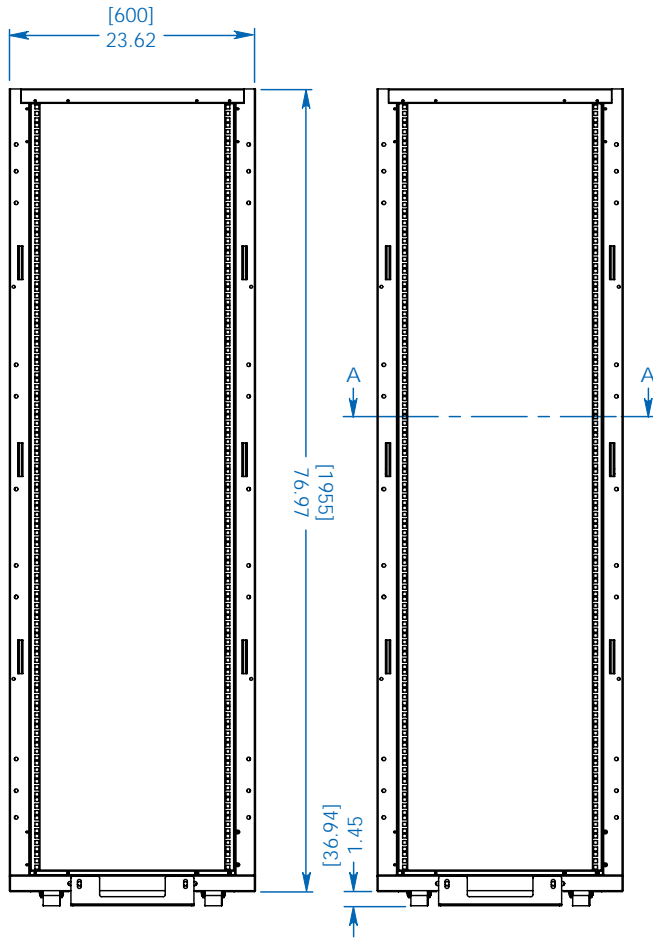

FRONT VIEW

REAR VIEW

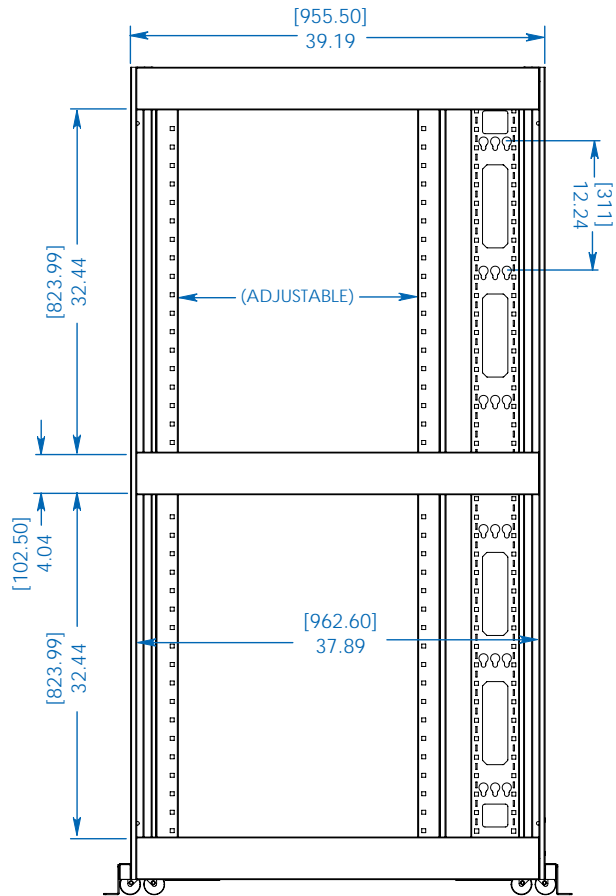

SIDE VIEW

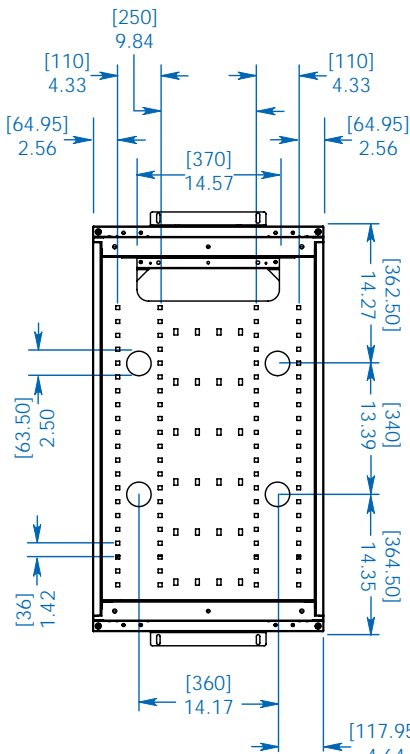

TOP VIEW

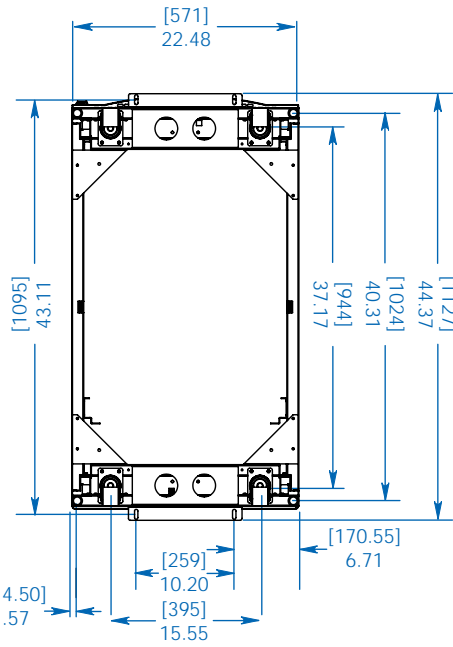

BOTTOM VIEW

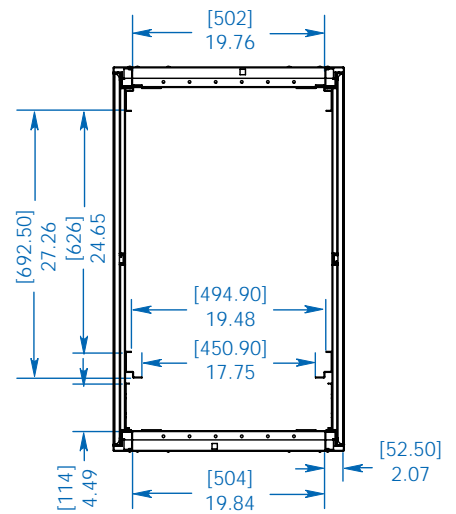

CROSS SECTION A

Dimensions: [mm] INCHES

Tripp Lite has a policy of continuous improvement. Specifications are subject to change without notice.

MODEL:
SR42UBEXPND
TRIPP-LITE

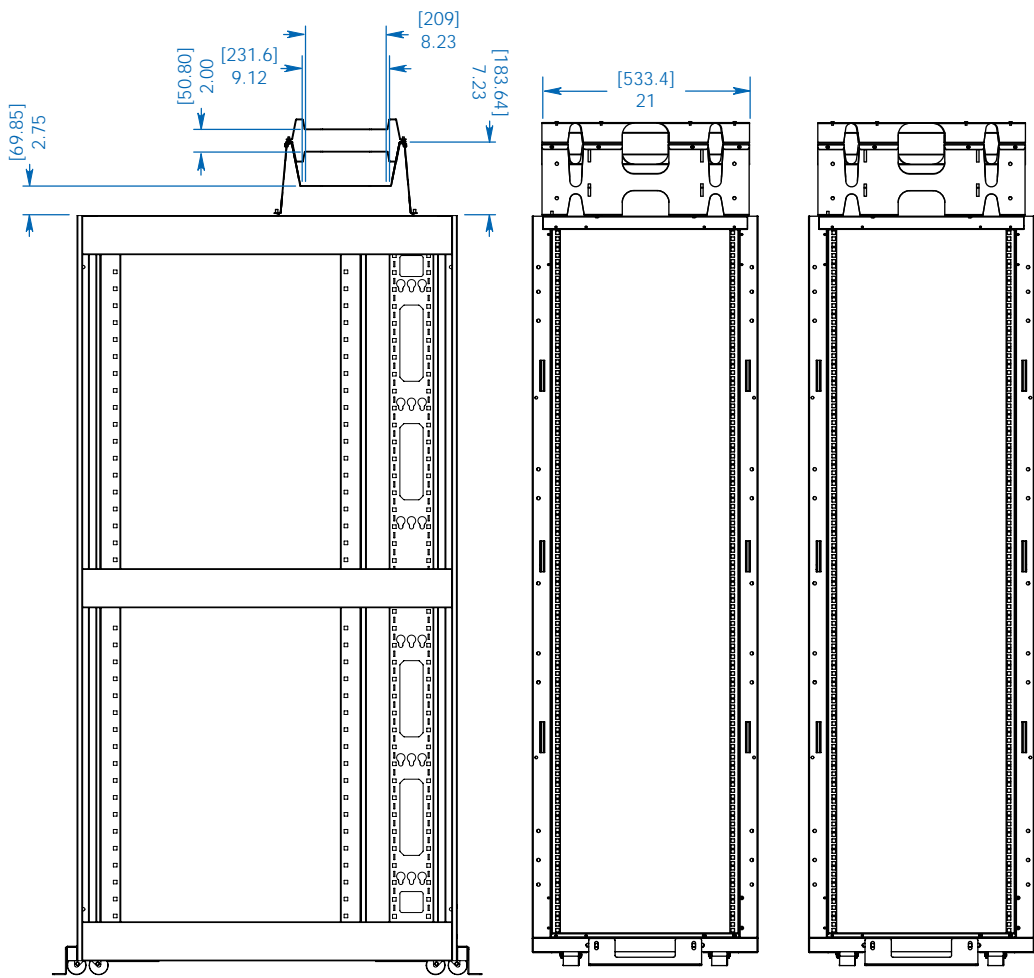

OPTIONAL SRCABLETRAY AND SRCABLETRAYEXP CABLE MANAGEMENT ACCESSORIES SHOWN (MOUNTING POSITION ADJUSTS TO ACCOMMODATE A WIDE RANGE OF APPLICATIONS)

SIDE VIEW

REAR VIEW

FRONT VIEW

Dimensions: [mm] INCHES

Tripp Lite has a policy of continuous improvement. Specifications are subject to change without notice.

MODEL:
SR42UBEXPND
TRIPP·LITE

1111 W. 35th Street
 Chicago, IL 60609 USA
 773.869.1234
 www.triplite.com