

MODEL:

SR42UBEXPNDNR3

SmartRack™ Heavy-Duty Open Frame Rack



42 Rack Units



3000 lb Stationary Load Capacity



3000 lb Rolling Load Capacity



Rolling Casters



Standard 19-inch Rack Width



Toolless Mounting Slots



Adjustable Rails with Easy-View Depth Index



Integrated Baying Tabs



Square Hole Mounting

- A** Adjustable Mounting Rails (4)
- B** Adjustable PDU Mounting Rails with Toolless Mounting Slots (2) (Hold up to 4 vertical PDUs.)
- C** 3-Inch Heavy-Duty Casters (4)
- D** Heavy-Duty Levelers (4)

Also Includes: Owner's manual, 2 shipping/stabilizing brackets and rackmount equipment mounting hardware (50 cage nuts, 50 mounting screws, 50 nylon cup washers).

- Rack ships fully assembled for rapid deployment, but can be knocked down for easy reassembly in confined spaces
- Modular design optimized for quick configuration and reconfiguration
- Ideal for rackmount server, network and telecom applications

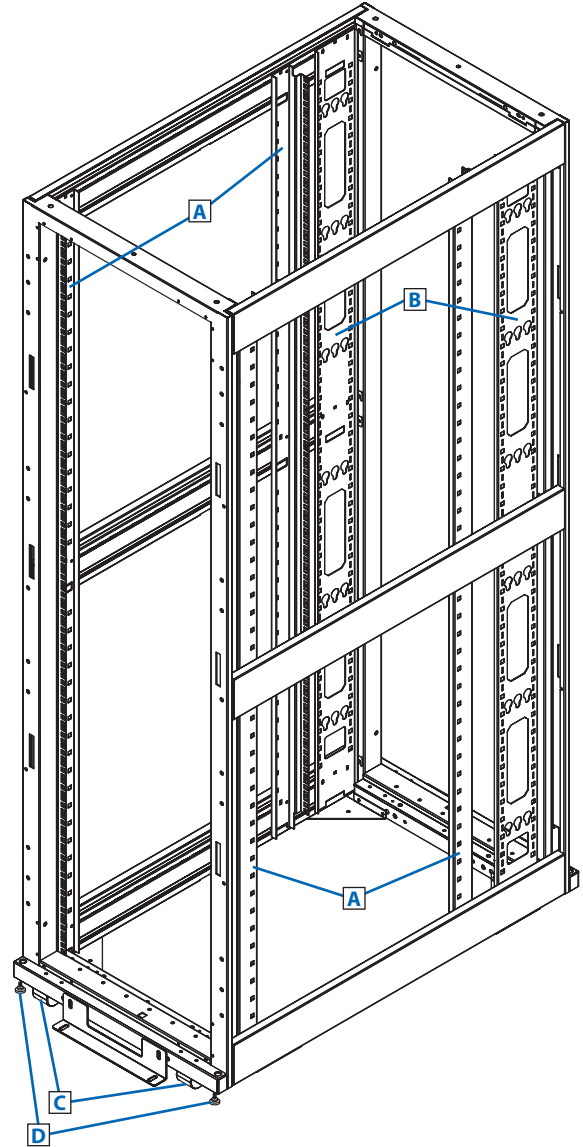

SEE NEXT PAGE FOR DETAILED UNIT MEASUREMENTS



1111 W. 35th Street
Chicago, IL 60609 USA
773.869.1234
www.tripplite.com



Specifications

Model	SR42UBEXPNDNR3
Rack Spaces	42U
Stationary Load Capacity	3000 lb (1363 kg)
Rolling Load Capacity	3000 lb (1363 kg)
Unit Dimensions (H x W x D)	78.5 x 23.63 x 41.5 in (1994 x 600 x 1053 mm)
Shipping Dimensions (H x W x D)	85 x 26 x 45 in (2159 x 660 x 1143 mm)
Unit Weight	150 lb (68 kg)
Shipping Weight	200 lb (90.7 kg)
Certifications	EIA-310-E, IEC 60297-3-100, DIN 41494, UL 60950, RoHS, NOM

Tripp Lite has a policy of continuous improvement. Specifications are subject to change without notice.

Also Available: Shock pallet models with special packaging to facilitate equipment pre-installation and reshipment to final site. Heavy-duty shock pallet holds up to 1250 lb (568 kg), including the weight of the rack and pre-installed equipment. Add "SP1" to model numbers above to order shock pallet models.

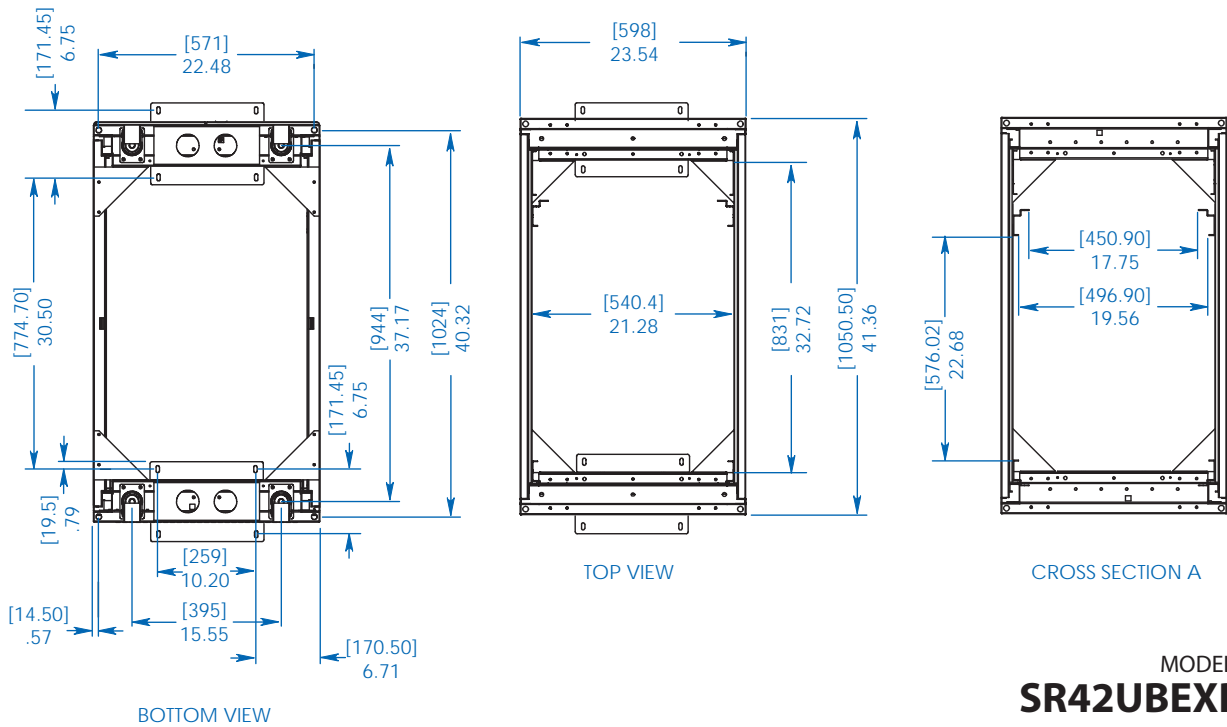
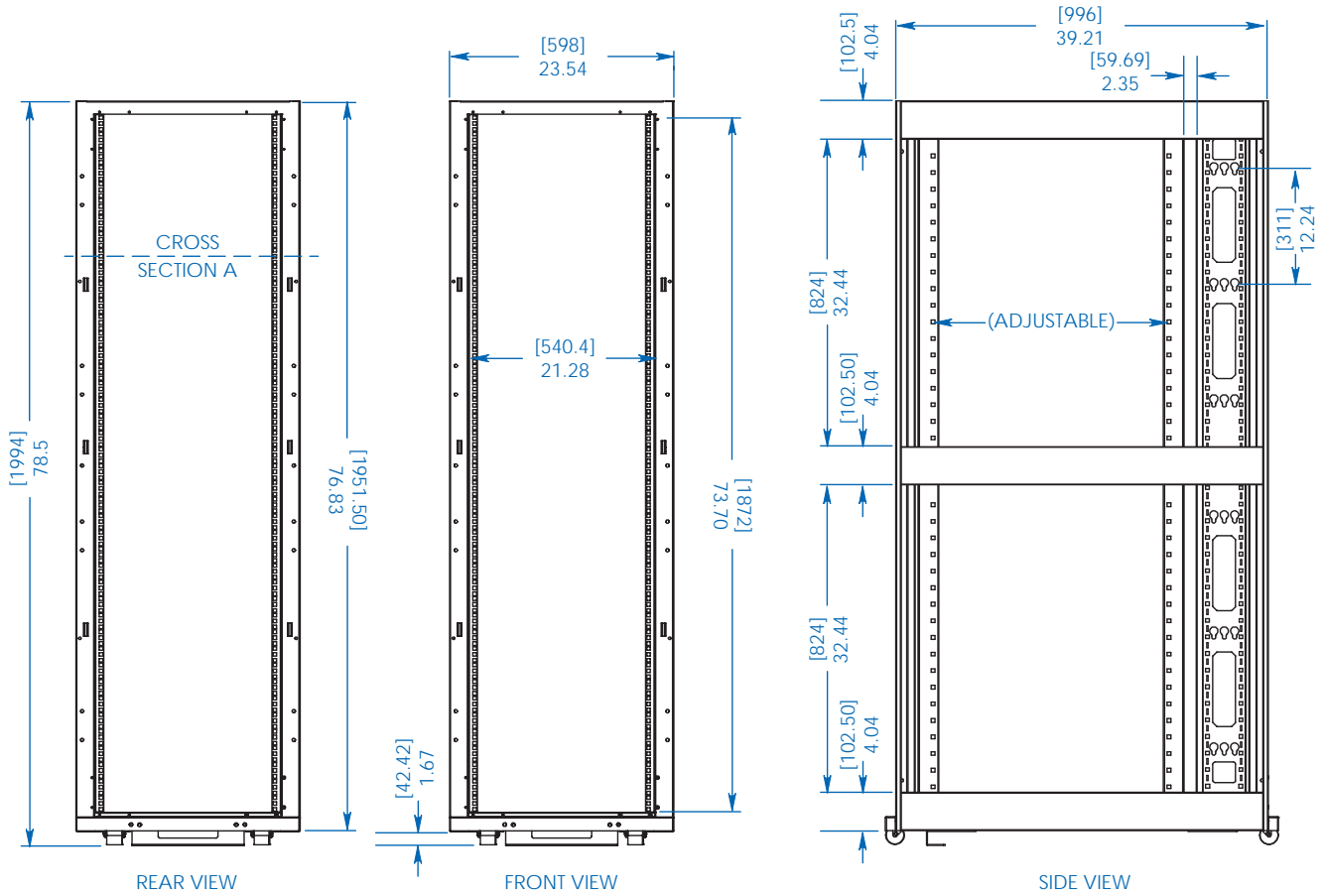

MODEL:
SR42UBEXPNDNR3



1111 W. 35th Street
Chicago, IL 60609 USA
773.869.1234

www.tripplite.com

Dimensions: [mm] INCHES

Tripp Lite has a policy of continuous improvement. Specifications are subject to change without notice.