

MODEL:

SR18UB

SmartRack® Premium Rack Enclosure



18 Rack Units



3000 lb
Stationary
Load Rating



2250 lb
Rolling
Load Rating



Heavy-Duty
Casters



Locking Doors
& Side Panels



Accommodates
Standard
19-inch
Equipment



Toolless
Mounting Slots



Adjustable
Rails with
Easy-View
Depth Index



Airflow
Exceeds
Server OEM
Requirements



Integrated
Baying Tabs



Square Hole
Mounting

- A** Locking/Reversible Front Door
- B** Locking/Reversible Back Door
- C** Horizontal Rails
- D** Vertical Mounting Rails
- E** Vents
- F** Cable Access Panel
- G** Locking/Removable Side Panels
- H** Heavy-Duty Casters
- I** Heavy-Duty Levelers
- J** Keys (For doors and side panels)

Also Includes: Owner's manual and rackmount equipment mounting hardware (42 cage nuts, 42 mounting screws, 42 nylon cup washers)

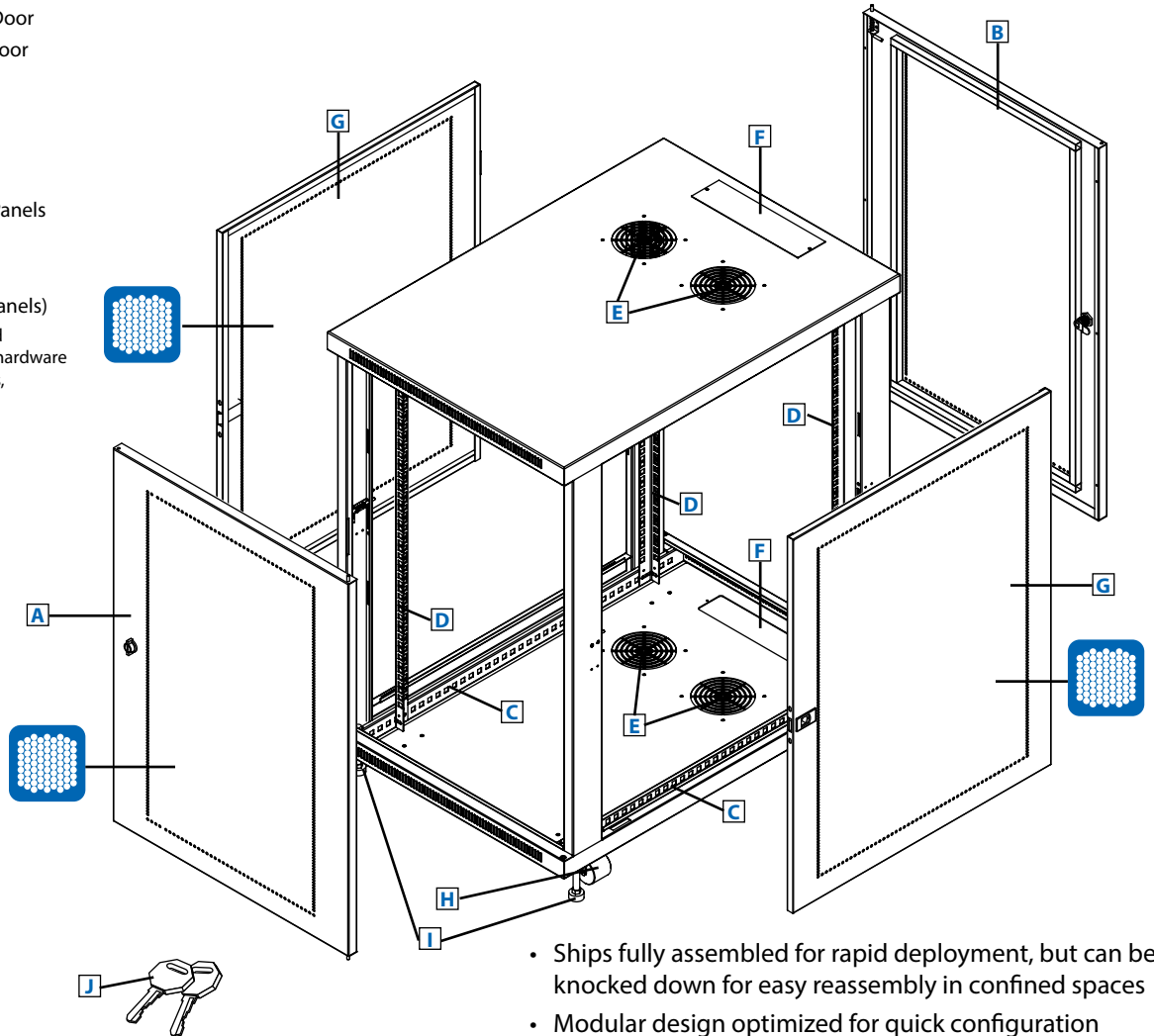

- Ships fully assembled for rapid deployment, but can be knocked down for easy reassembly in confined spaces
- Modular design optimized for quick configuration and reconfiguration
- Ideal for rackmount server, network and telecom applications

Specifications

Model	SR18UB
Rack Spaces	18U
Stationary Load Rating	3000 lb (1363 kg)
Rolling Load Rating	2250 lb (1022 kg)
Unit Dimensions (H x W x D)	35.6 x 23.63 x 33.5 in (904.2 x 600.2 x 850.9 mm)
Shipping Dimensions (H x W x D)	41.61 x 25.6 x 35.03 in (1056.9 x 650.2 x 889.8 mm)
Unit Weight / Shipping Weight	105 lb (47.63 kg) / 123 lb (55.79 kg)
Standards	Meets UL 60950, EIA-310-E, NOM and RoHS standards

Tripp Lite has a policy of continuous improvement. Specifications are subject to change without notice.



SEE NEXT PAGE FOR DETAILED UNIT MEASUREMENTS



1111 W. 35th Street
Chicago, IL 60609 USA
773.869.1234
www.tripplite.com

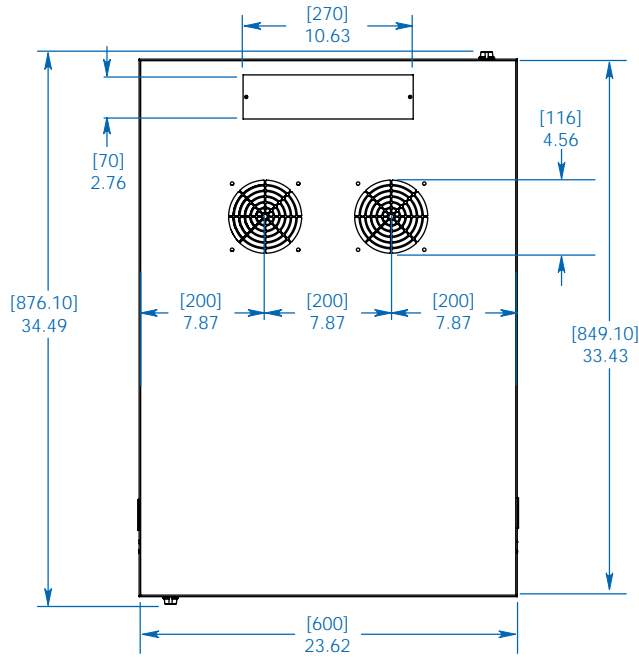

TOP VIEW

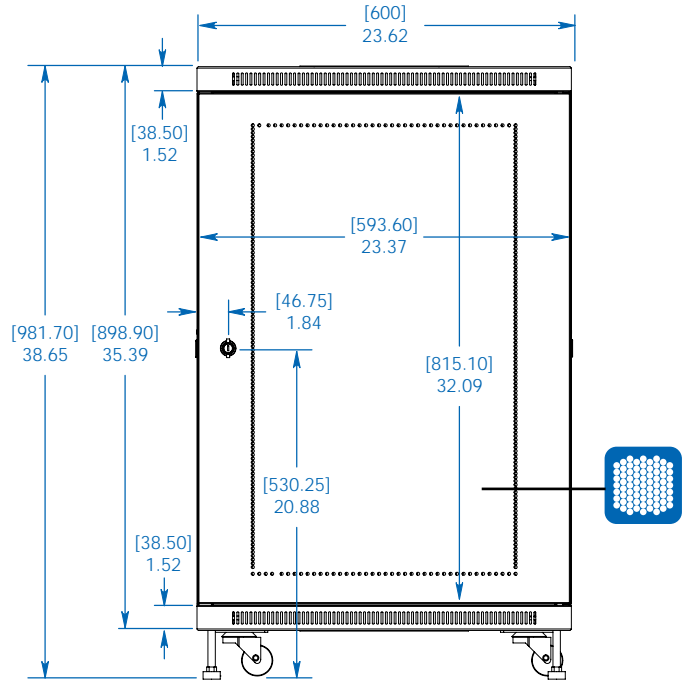

FRONT/REAR VIEW

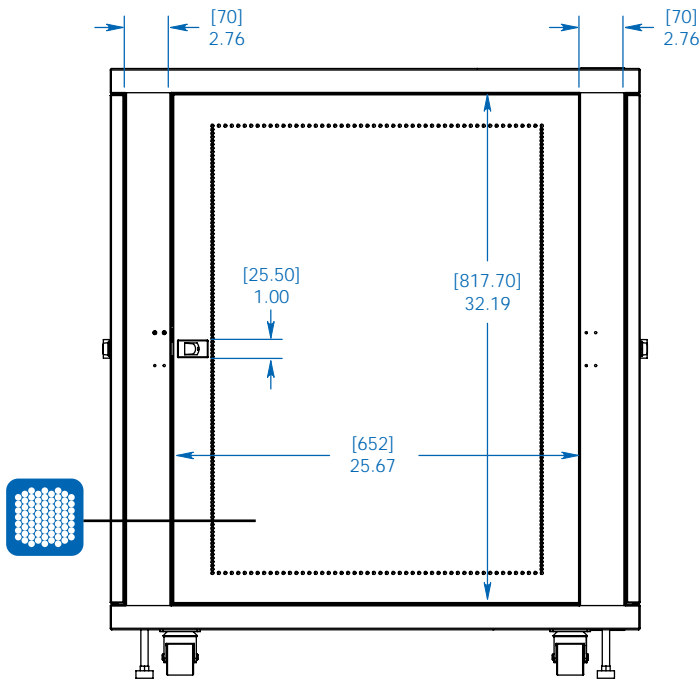

SIDE VIEW

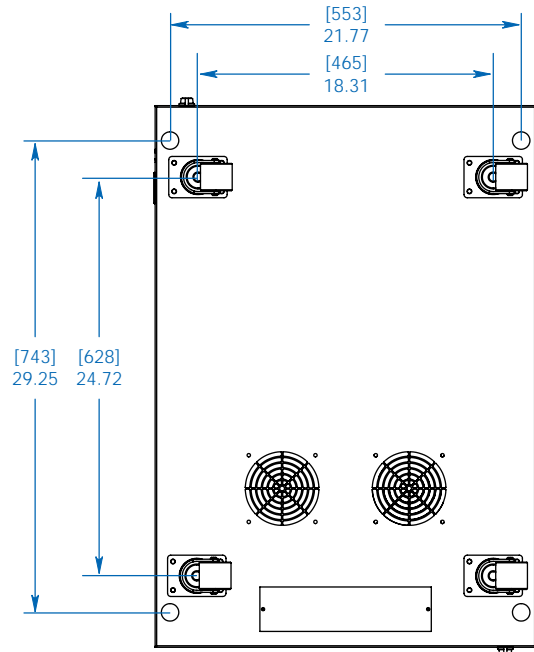

BOTTOM VIEW

Dimensions: [mm] INCHES

Tripp Lite has a policy of continuous improvement. Specifications are subject to change without notice.

MODEL:
SR18UB
TRIPP-LITE

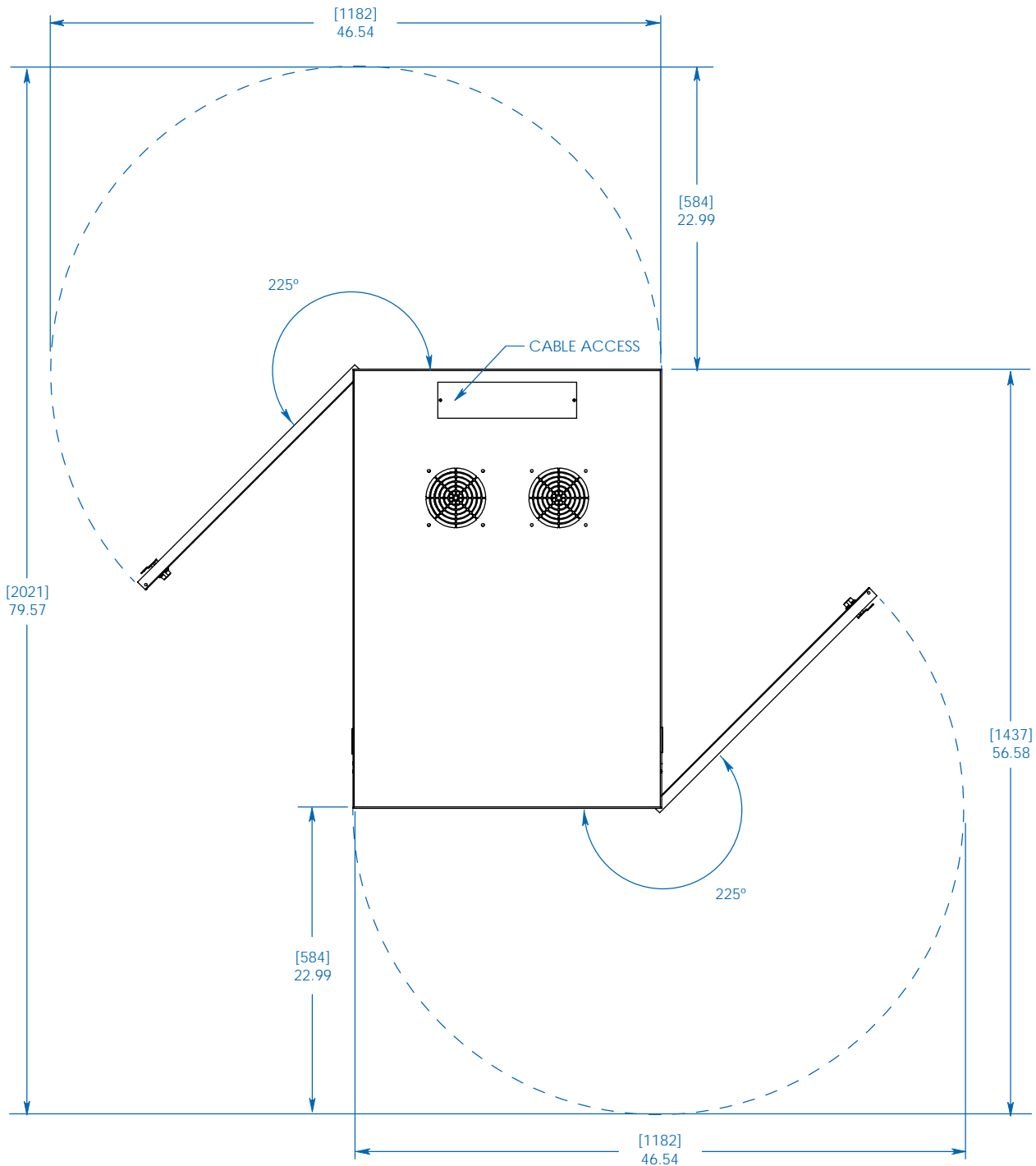

TOP VIEW

MODEL:
SR18UB



1111 W. 35th Street
Chicago, IL 60609 USA
773.869.1234
www.tripplite.com

Dimensions: [mm] INCHES

Tripp Lite has a policy of continuous improvement. Specifications are subject to change without notice.