

# Technical Specifications

Symmetra™ LX

208 V/240 V



## American Power Conversion Legal Disclaimer

The information presented in this manual is not warranted by the American Power Conversion Corporation to be authoritative, error free, or complete. This publication is not meant to be a substitute for a detailed operational and site specific development plan. Therefore, American Power Conversion Corporation assumes no liability for damages, violations of codes, improper installation, system failures, or any other problems that could arise based on the use of this Publication.

The information contained in this Publication is provided as is and has been prepared solely for the purpose of evaluating data center design and construction. This Publication has been compiled in good faith by American Power Conversion Corporation. However, no representation is made or warranty given, either express or implied, as to the completeness or accuracy of the information this Publication contains.

**IN NO EVENT SHALL AMERICAN POWER CONVERSION CORPORATION, OR ANY PARENT, AFFILIATE OR SUBSIDIARY COMPANY OF AMERICAN POWER CONVERSION CORPORATION OR THEIR RESPECTIVE OFFICERS, DIRECTORS, OR EMPLOYEES BE LIABLE FOR ANY DIRECT, INDIRECT, CONSEQUENTIAL, PUNITIVE, SPECIAL, OR INCIDENTAL DAMAGES (INCLUDING, WITHOUT LIMITATION, DAMAGES FOR LOSS OF BUSINESS, CONTRACT, REVENUE, DATA, INFORMATION, OR BUSINESS INTERRUPTION) RESULTING FROM, ARISING OUT, OR IN CONNECTION WITH THE USE OF, OR INABILITY TO USE THIS PUBLICATION OR THE CONTENT, EVEN IF AMERICAN POWER CONVERSION CORPORATION HAS BEEN EXPRESSLY ADVISED OF THE POSSIBILITY OF SUCH DAMAGES. AMERICAN POWER CONVERSION CORPORATION RESERVES THE RIGHT TO MAKE CHANGES OR UPDATES WITH RESPECT TO OR IN THE CONTENT OF THE PUBLICATION OR THE FORMAT THEREOF AT ANY TIME WITHOUT NOTICE.**

Copyright, intellectual, and all other proprietary rights in the content (including but not limited to software, audio, video, text, and photographs) rests with American Power Conversion Corporation or its licensors. All rights in the content not expressly granted herein are reserved. No rights of any kind are licensed or assigned or shall otherwise pass to persons accessing this information.

This Publication shall not be for resale in whole or in part.

# Table of Contents

<b>Technical Data</b> .....	<b>3</b>
Model List.....	3
Input Power Factor.....	3
Efficiency.....	4
Efficiency Curves.....	4
<b>Batteries and Runtime</b> .....	<b>6</b>
Battery Run-Times — APC Battery Solutions.....	6
Battery Specifications.....	13
Battery Gassing Rates .....	14
Battery Material Safety Data Sheet .....	14
<b>Compliance</b> .....	<b>15</b>
<b>Facility Planning</b> .....	<b>16</b>
Specifications for Installations .....	16
AC Input .....	16
AC Output .....	18
Configuration and Management.....	20
Powerview User Interface .....	20
Network Management Card 2 .....	20
Remote Emergency Power Off (REPO) .....	20
Physical.....	22
Weights and Dimensions.....	22
Shipping Weights and Dimensions.....	23
Environmental .....	24
Requirements for Operation and Storage .....	24
Heat Dissipation .....	24
Drawings .....	25
SYA4K8P: Symmetra LX 4 kVA Scalable to 8 kVA N+1 Tower, 208/240 V.....	26
SYA4K8RMP: Symmetra 4 kVA Scalable to 8 kVA N+1 Rack-Mount, 208/240 V .....	27

SYA8K16P: Symmetra 8 kVA Scalable to 16 kVA N+1, Tower, 208/240 V .....	28
SYA8K16PXR: Symmetra 8 kVA Scalable to 16 kVA N+1 Ext. Run Tower, 208/240 V .....	29
SYA8K16RMP: Symmetra 8 kVA Scalable to 16 kVA N+1 Rack-Mount, 208/240 V .....	30
SYA8K8P: Symmetra 8 kVA Scalable to 8 kVA N+1 Tower, 208/240 V .....	31
SYA8K8RMP: Symmetra 8 kVA Scalable to 8 kVA N+1 Rack-Mount, 208/240 V .....	32
SYA12K16P: Symmetra 12 kVA Scalable to 16 kVA N+1 Tower, 208/240 V .....	33
SYA12K16PXR: Symmetra 12 kVA Scalable to 16 kVA N+1 Ext. Run Tower, 208/240 V ..	34
SYA12K16RMP: Symmetra 12 kVA Scalable to 16 kVA N+1 Rack-Mount, 208/240 V .....	35
SYA16K16P: Symmetra 16 kVA Scalable to 16 kVA N+1 Tower, 208/240 V .....	36
SYA16K16PXR: Symmetra 16 kVA Scalable to 16 kVA N+1 Ext. Run Tower, 208/240 V ..	37
SYA16K16RMP: Symmetra 16 kVA Scalable to 16 kVA N+1 Rack-Mount, 208/240 V .....	38
<b>Options .....</b>	<b>39</b>
Hardware Options .....	39
Symmetra Battery Systems .....	39
Symmetra Battery Cables .....	39
Interface Cables .....	39
UPS Network Management Cards .....	39
Additional Management Cards and Options.....	39
Rack-Mounting Hardware.....	39
Maintenance Bypass Panels .....	40
Isolation Transformers.....	40
Power Distribution Units .....	40
Backplates and Panels.....	40
Power Modules for N+1 Redundancy.....	40
Parts and Accessories.....	40
Software Options.....	41
<b>Limited Warranty .....</b>	<b>42</b>

# Technical Data

---



**Note:** Unless otherwise noted, data contained in these technical specifications should be considered typical; actual performance may vary.

## Model List

- SYA4K8P: APC™ Symmetra LX 4 kVA scalable to 8 kVA N+1 Tower, 208/240 V
- SYA4K8RMP: APC Symmetra LX 4 kVA scalable to 8 kVA N+1 Rack-mount, 208/240 V
- SYA8K16P: APC Symmetra LX 8 kVA scalable to 16 kVA N+1 Tower, 208/240 V
- SYA8K16PXR: APC Symmetra LX 8 kVA scalable to 16 kVA N+1 Ext. Run Tower, 208/240 V
- SYA8K16RMP: APC Symmetra LX 8 kVA scalable to 16 kVA N+1 Rack-mount, 208/240 V
- SYA8K8P: APC Symmetra LX 8 kVA scalable to 8 kVA N+1 Tower, 208/240 V
- SYA8K8RMP: APC Symmetra LX 8 kVA scalable to 8 kVA N+1 Rack-mount, 208/240 V
- SYA12K16P: APC Symmetra LX 12 kVA scalable to 16 kVA N+1 Tower, 208/240 V
- SYA12K16PXR: APC Symmetra LX 12 kVA scalable to 16 kVA N+1 Ext. Run Tower, 208/240 V
- SYA12K16RMP: APC Symmetra LX 12 kVA scalable to 16 kVA N+1 Rack-mount, 208/240 V
- SYA16K16P: APC Symmetra LX 16 kVA scalable to 16 kVA N+1 Tower, 208/240 V
- SYA16K16PXR: APC Symmetra LX 16 kVA scalable to 16 kVA N+1 Ext. Run Tower, 208/240 V
- SYA16K16RMP: APC Symmetra LX 16 kVA scalable to 16 kVA N+1 Rack-mount, 208/240 V

## Input Power Factor

The input power factor is 0.90 at full load with 120/208 Vac source, 2PH + N + G, or 0.98 at full load with 120/240 Vac source, 2PH + N + G.

# Efficiency

## Efficiency Curves

These Symmetra LX models have the efficiency rating shown in the following table and graph:

- SYA4K8P: APC Symmetra LX 4 kVA scalable to 8 kVA N+1 Tower, 208/240 V
- SYA4K8RMP: APC Symmetra LX 4 kVA scalable to 8 kVA N+1 Rack-mount, 208/240 V
- SYA8K16P: APC Symmetra LX 8 kVA scalable to 16 kVA N+1 Tower, 208/240 V
- SYA8K16PXR: APC Symmetra LX 8 kVA scalable to 16 kVA N+1 Ext. Run Tower, 208/240 V
- SYA8K16RMP: APC Symmetra LX 8 kVA scalable to 16 kVA N+1 Rack-mount, 208/240 V
- SYA8K8P: APC Symmetra LX 8 kVA scalable to 8 kVA N+1 Tower, 208/240 V
- SYA8K8RMP: APC Symmetra LX 8 kVA scalable to 8 kVA N+1 Rack-mount, 208/240 V

Load	Efficiency
25%	84.1%
50%	88.3%
75%	89.5%
100%	89.9%

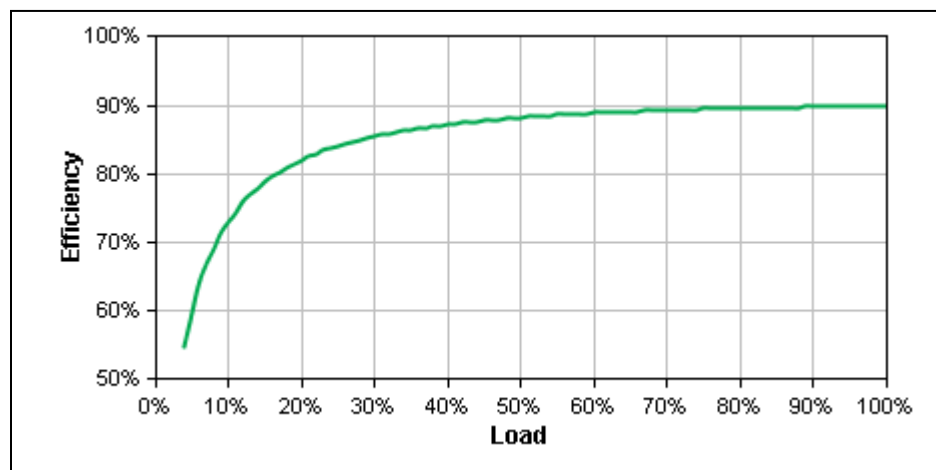

These Symmetra LX models have the efficiency rating shown in the following table and graph:

- SYA12K16P: APC Symmetra LX 12 kVA scalable to 16 kVA N+1 Tower, 208/240 V
- SYA12K16PXR: APC Symmetra LX 12 kVA scalable to 16 kVA N+1 Ext. Run Tower, 208/240 V
- SYA12K16RMP: APC Symmetra LX 12 kVA scalable to 16 kVA N+1 Rack-mount, 208/240 V

Load	Efficiency
25%	85.0%
50%	88.9%
75%	89.7%
100%	89.7%

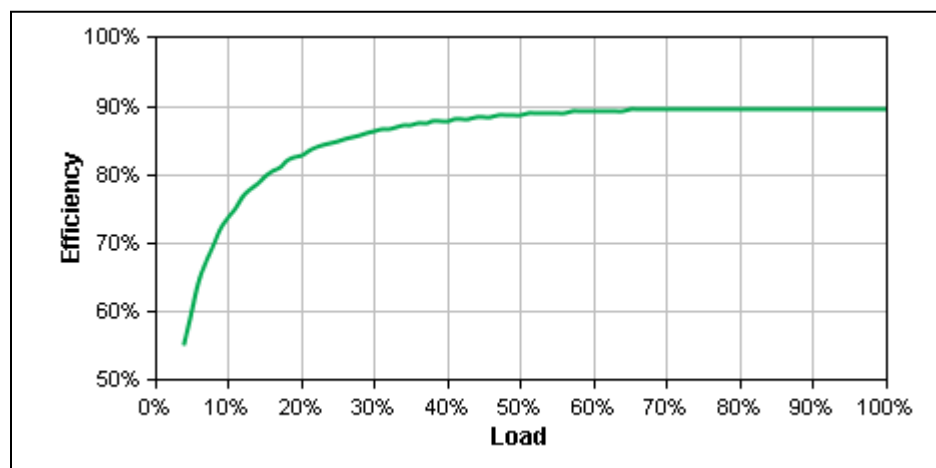

These Symmetra LX models have the efficiency rating shown in the following table and graph:

- SYA16K16P: APC Symmetra LX 16 kVA scalable to 16 kVA N+1 Tower, 208/240 V
- SYA16K16PXR: APC Symmetra LX 16 kVA scalable to 16 kVA N+1 Ext. Run Tower, 208/240 V
- SYA16K16RMP: APC Symmetra LX 16 kVA scalable to 16 kVA N+1 Rack-mount, 208/240 V

Load	Efficiency
25%	85.3%
50%	89.0%
75%	89.8%
100%	89.7%

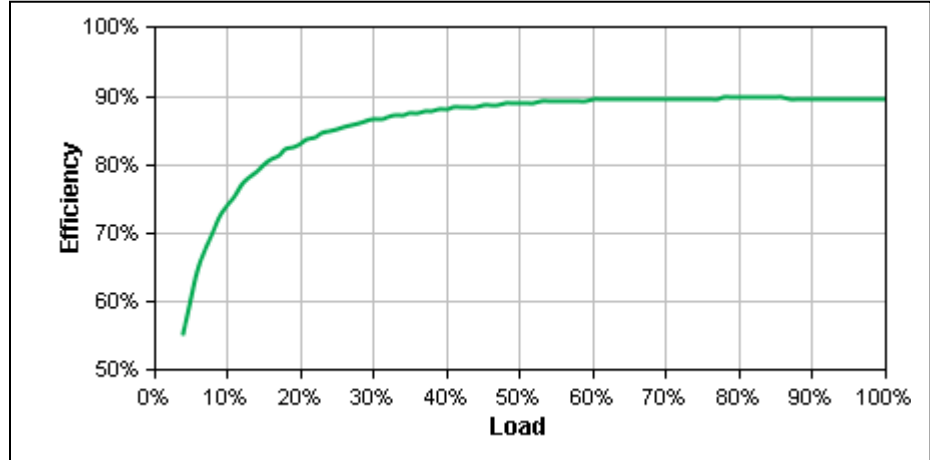

# Batteries and Runtime

## Battery Run-Times — APC Battery Solutions

SYA4K8P: APC Symmetra LX 4 kVA scalable to 8 kVA N+1 Tower, 208/240 V, Battery Run-Times (minutes):

Curve	Part number(s)
A	SYA4K8P
B	SYA4K8P + (1)SYBT5
C	SYA4K8P + (1)SYAXR9B9
D	SYA4K8P + (2)SYAXR9B9
E	SYA4K8P + (3)SYAXR9B9

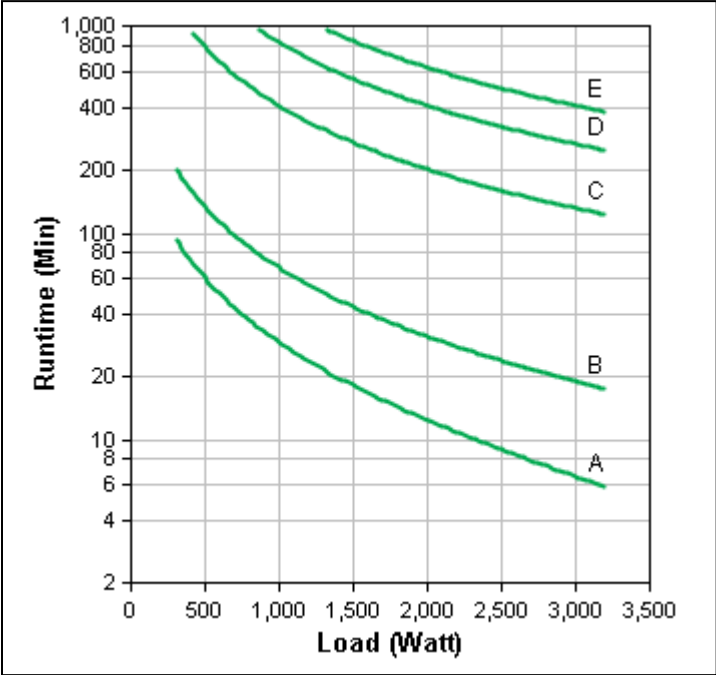

SYA4K8RMP: APC Symmetra LX 4 kVA scalable to 8 kVA N+1 Rack-mount, 208/240 V, Battery Run-Times (minutes):

Curve	Part number(s)
A	SYA4K8RMP
B	SYA4K8RMP + (1)SYBT5
C	SYA4K8RMP + (1)SYARMXR3B3
D	SYA4K8RMP + (2)SYARMXR3B3
E	SYA4K8RMP + (1)SYARMXR9B9

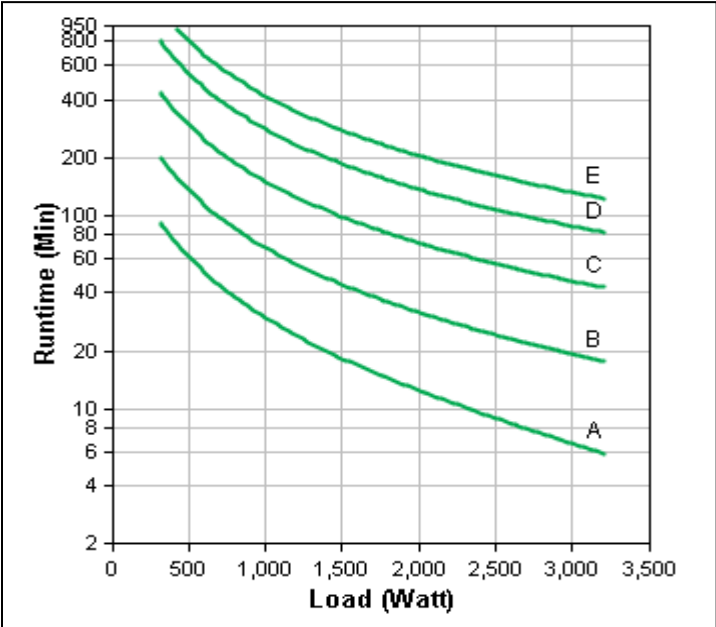



SYA8K16P: APC Symmetra LX 8 kVA scalable to 16 kVA N+1 Tower, 208/240 V, Battery Run-Times (minutes):

Curve	Part number(s)
A	SYA8K16P
B	SYA8K16P + (1)SYBT5
C	SYA8K16P + (2)SYBT5
D	SYA8K16P + (1)SYAXR9B9
E	SYA8K16P + (2)SYAXR9B9

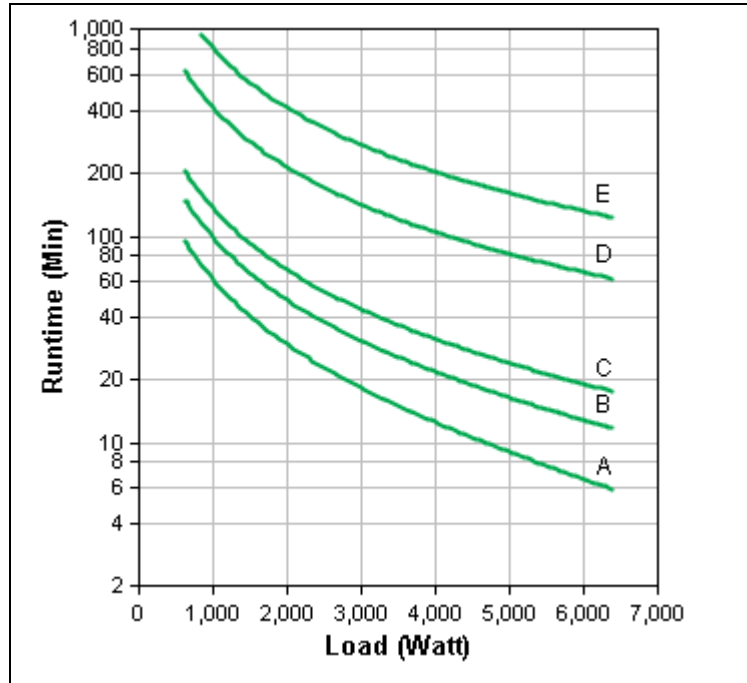

SYA8K16PXR: APC Symmetra LX 8 kVA scalable to 16 kVA N+1 Ext. Run Tower, 208/240 V, Battery Run-Times (minutes):

Curve	Part number(s)
A	SYA8K16PXR
B	SYA8K16PXR + (2)SYBT5
C	SYA8K16PXR + (4)SYBT5
D	SYA8K16PXR + (1)SYAXR9B9
E	SYA8K16PXR + (2)SYAXR9B9

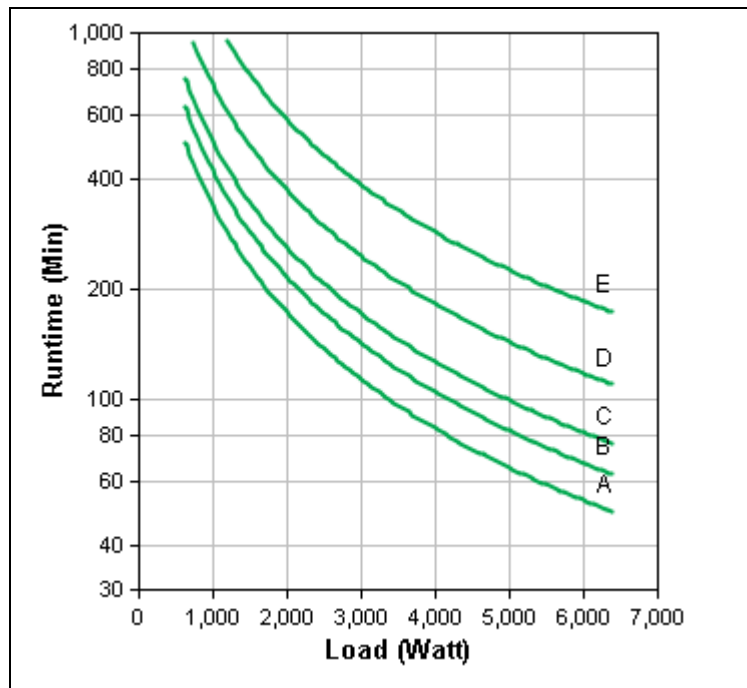

SYA8K16RMP: APC Symmetra LX 8 kVA scalable to 16 kVA N+1 Rack-mount, 208/240 V, Battery Run-Times (minutes):

Curve	Part number(s)
A	SYA8K16RMP
B	SYA8K16RMP + (2)SYBT5
C	SYA8K16RMP + (1)SYARMXR3B3
D	SYA8K16RMP + (2)SYARMXR3B3
E	SYA8K16RMP + (1)SYARMXR9B9

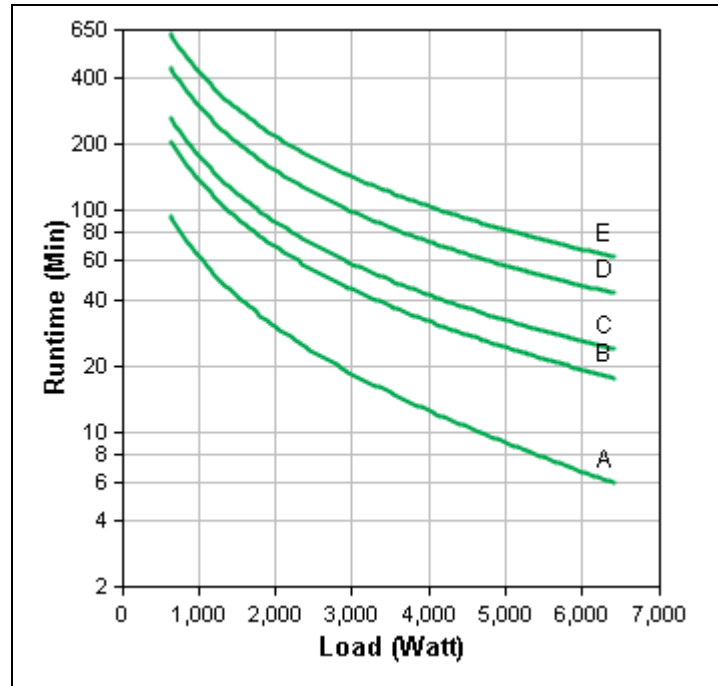

SYA8K8P: APC Symmetra LX 8 kVA scalable to 8 kVA N+1 Tower, 208/240 V, Battery Run-Times (minutes):

Curve	Part number(s)
A	SYA8K8P
B	SYA8K8P + (1)SYAXR9B9
C	SYA8K8P + (2)SYAXR9B9
D	SYA8K8P + (3)SYAXR9B9
E	SYA8K8P + (4)SYAXR9B9

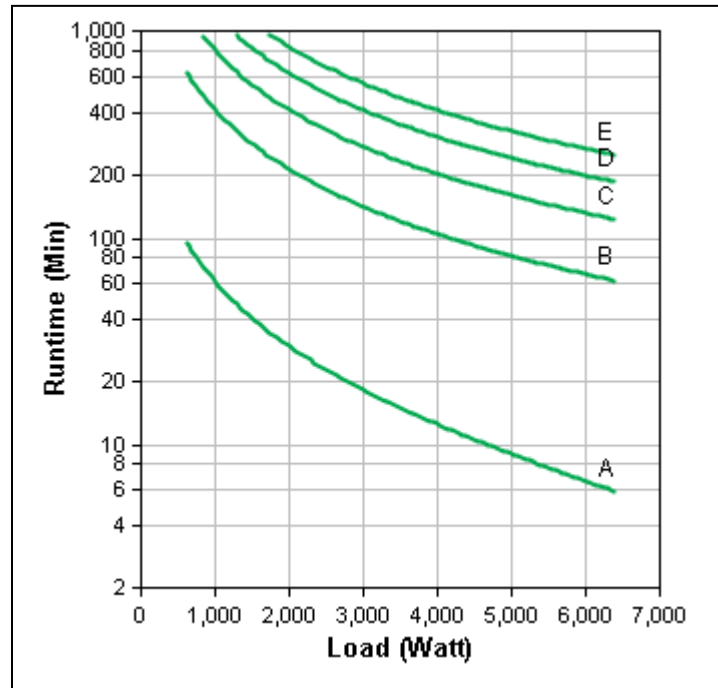

SYA8K8RMP: APC Symmetra LX 8 kVA scalable to 8 kVA N+1 Rack-mount, 208/240 V, Battery Run-Times (minutes):

Curve	Part number(s)
A	SYA8K8RMP
B	SYA8K8RMP + (1)SYARMXR3B3
C	SYA8K8RMP + (2)SYARMXR3B3
D	SYA8K8RMP + (1)SYARMXR9B9
E	SYA8K8RMP + (2)SYARMXR9B9

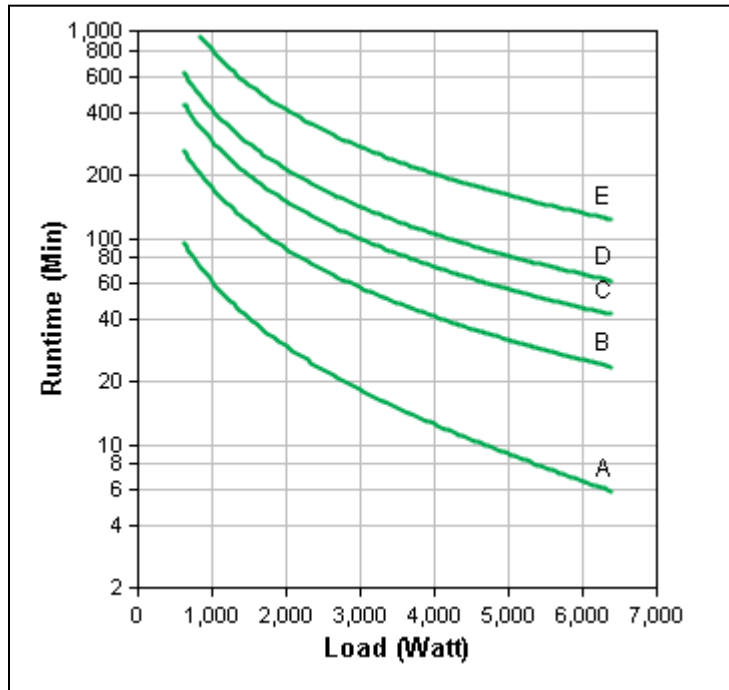

SYA12K16P: APC Symmetra LX 12 kVA scalable to 16 kVA N+1 Tower, 208/240 V, Battery Run-Times (minutes):

Curve	Part number(s)
A	SYA12K16P
B	SYA12K16P + (1)SYBT5
C	SYA12K16P + (1)SYAXR9B9
D	SYA12K16P + (2)SYAXR9B9
E	SYA12K16P + (3)SYAXR9B9

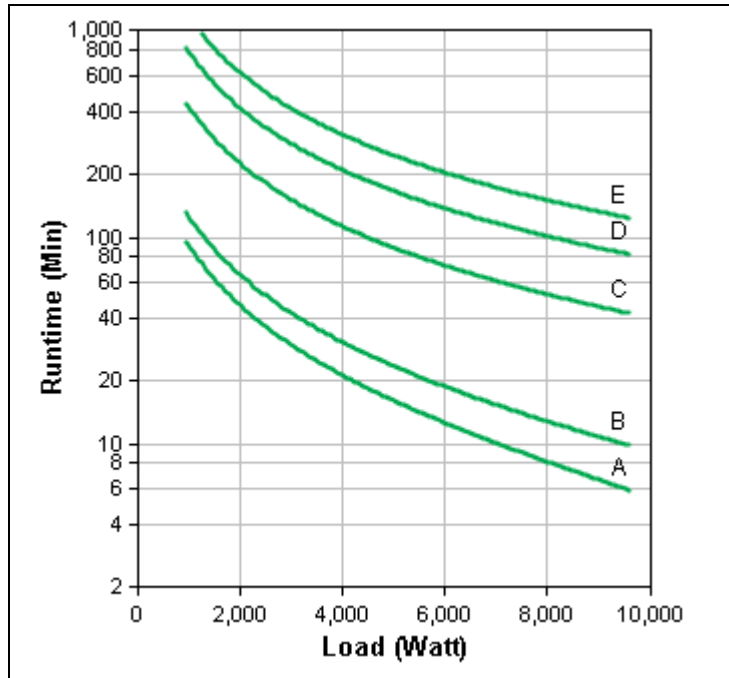

SYA12K16PXR: APC Symmetra LX 12 kVA scalable to 16 kVA N+1 Ext. Run Tower, 208/240 V, Battery Run-Times (minutes):

Curve	Part number(s)
A	SYA12K16PXR
B	SYA12K16PXR + (2)SYBT5
C	SYA12K16PXR + (4)SYBT5
D	SYA12K16PXR + (1)SYAXR9B9
E	SYA12K16PXR + (2)SYAXR9B9

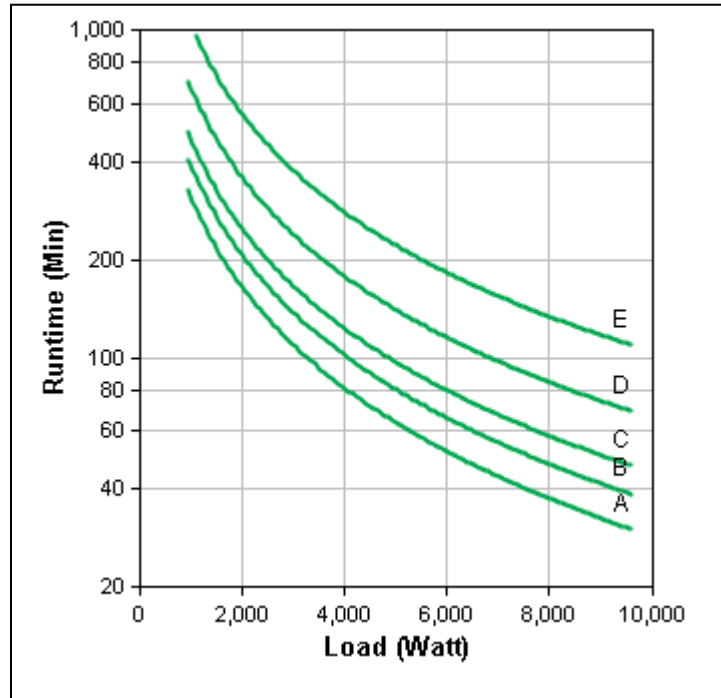

SYA12K16RMP: APC Symmetra LX 12 kVA scalable to 16 kVA N+1 Rack-mount, 208/240 V, Battery Run-Times (minutes):

Curve	Part number(s)
A	SYA12K16RMP
B	SYA12K16RMP + (1)SYBT5
C	SYA12K16RMP + (1)SYARMXR3B3
D	SYA12K16RMP + (2)SYARMXR3B3
E	SYA12K16RMP + (1)SYARMXR9B9

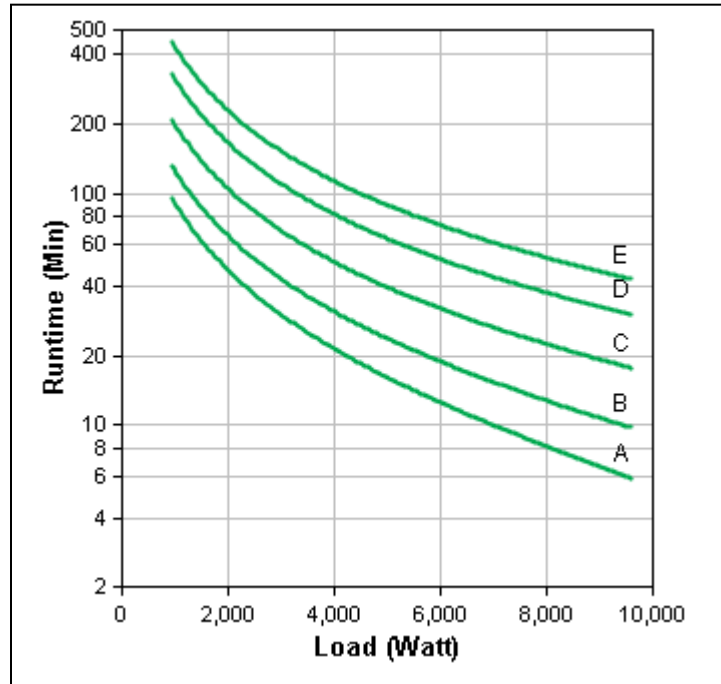

SYA16K16P: APC Symmetra LX 16 kVA scalable to 16 kVA N+1 Tower, 208/240 V, Battery Run-Times (minutes):

Curve	Part number(s)
A	SYA16K16P
B	SYA16K16P + (1)SYAXR9B9
C	SYA16K16P + (2)SYAXR9B9
D	SYA16K16P + (3)SYAXR9B9
E	SYA16K16P + (4)SYAXR9B9

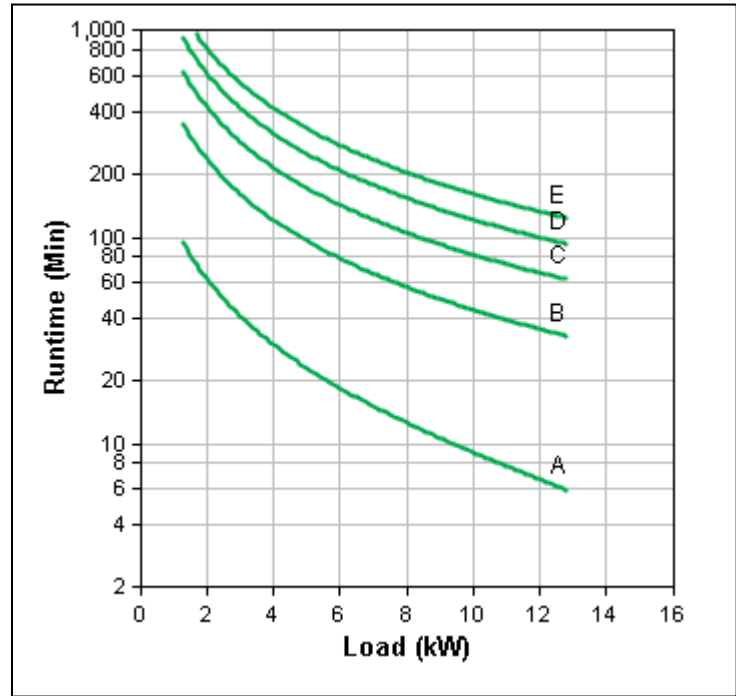

SYA16K16PXR: APC Symmetra LX 16 kVA scalable to 16 kVA N+1 Ext. Run Tower, 208/240 V, Battery Run-Times (minutes):

Curve	Part number(s)
A	SYA16K16PXR
B	SYA16K16PXR + (2)SYBT5
C	SYA16K16PXR + (4)SYBT5
D	SYA16K16PXR + (1)SYAXR9B9
E	SYA16K16PXR + (2)SYAXR9B9

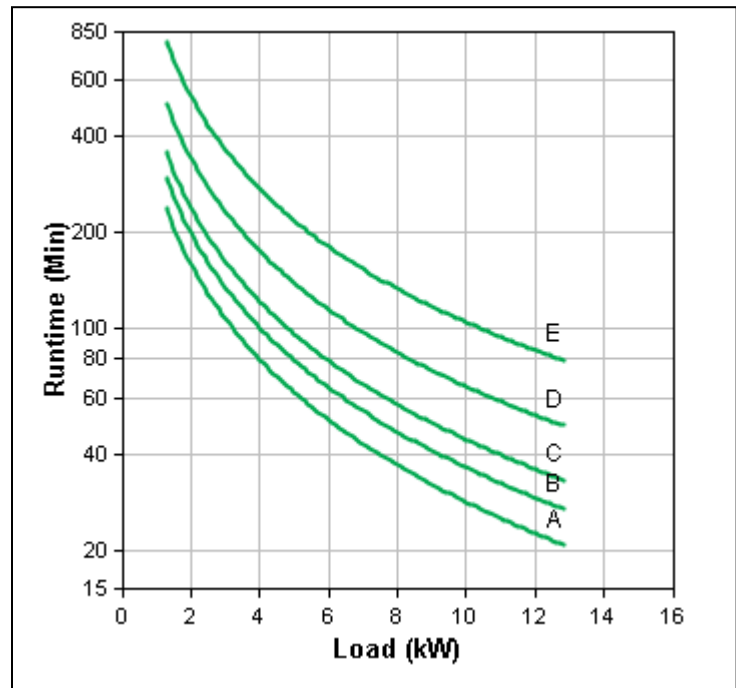

SYA16K16RMP: APC Symmetra LX 16 kVA Scalable to 16 kVA N+1 Rack-mount, 208/240 V, Battery Run-Times (minutes):

Curve	Part number(s)
A	SYA16K16RMP
B	SYA16K16RMP + (1)SYARMXR3B3
C	SYA16K16RMP + (2)SYARMXR3B3
D	SYA16K16RMP + (1)SYARMXR9B9
E	SYA16K16RMP + (2)SYARMXR9B9

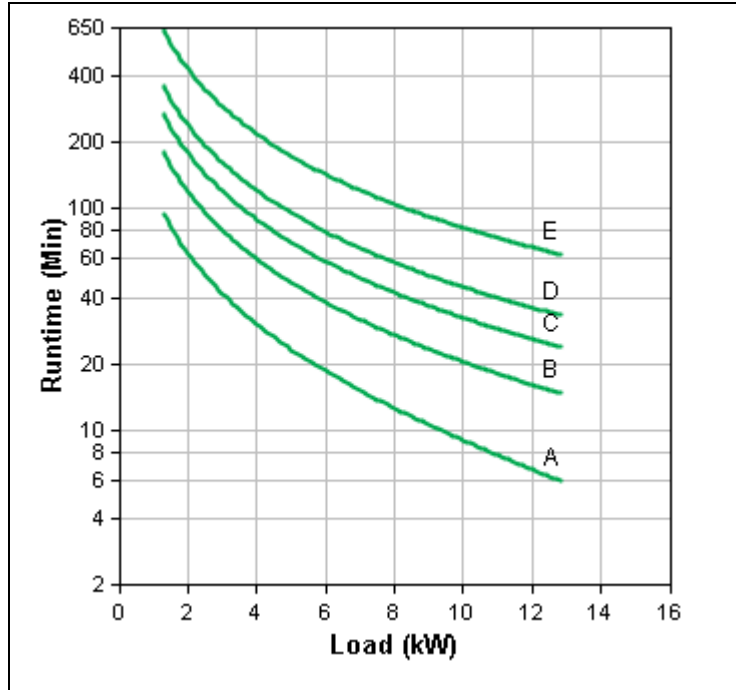

# Battery Specifications

Symmetra LX Model	16 kVA Extended Run Tower	16 kVA Tower	8 kVA Tower	16 kVA Rack-mount	8 kVA Rack-mount
SKU	SYA16K16PXR	SYA16K16P	SYA8K8P	SYA16K16RMP	SYA8K8RMP
Type	Maintenance-free valve-regulated lead-acid battery with suspended electrolyte, leak-proof				
Battery Module SKU	SYBT5 (or optional SYBT5FR with flame-retardant case)				
Hot Swappable	Yes				
User Replaceable	Yes				
Battery Voltage, Vdc	100 - 147 Vdc (120 Vdc nominal)				
Battery Amp-Hour Capacity	9.0 Ah				
Battery Charge Power Rating	300 W per installed Power Module				
Minimum Input Voltage to Charge	71 Vac L-N				
Recharge Time 0% to 90% <sup>1</sup>	7.5 hours	3 hours			
Automatic Self-Test	At turn-on, every 7 days, or every 14 days (user-selectable)				
Intelligent Battery Management	Yes				
Typical Battery Life	3 to 6 years				
Extended Runtime Option	Yes				
External Extended Run Frames	6 maximum	7 maximum			
<sup>1</sup> Systems configured with external extended run (XR) battery frames have longer recharge times.					

# Battery Gassing Rates



**Note:** We recommend that room ventilation is based on maximum values.

Gassing Rates per Hour for a Single SYBT5 Battery Module	
Typical	Maximum
10.3 cm <sup>3</sup>	18 cm <sup>3</sup>

# Battery Material Safety Data Sheet



**Note:** For Material Safety Data Sheet (MSDS), go to [http://nam-en.apc.com/app/answers/detail/a\\_id/564/kw/msds](http://nam-en.apc.com/app/answers/detail/a_id/564/kw/msds).



# Compliance

---

<b>Regulatory Approvals</b>	
<b>All Symmetra LX Models</b>	CSA, FCC Part 15 Class A, UL 1778
<b>SYA4K8RMP: APC Symmetra LX 4 kVA scalable to 8 kVA N+1 Rack-mount, 208 V/240 V</b>	OSHPD, Preapproval
<b>SYA8K16RMP: APC Symmetra LX 8 kVA scalable to 16 kVA N+1 Rack-mount, 208 V/240 V</b>	
<b>SYA8K8RMP: APC Symmetra LX 8 kVA scalable to 8 kVA N+1 Rack-mount, 208 V/240 V</b>	
<b>SYA12K16RMP: APC Symmetra LX 12 kVA scalable to 16 kVA N+1 Rack-mount, 208 V/240 V</b>	
<b>SYA16K16RMP: APC Symmetra LX 16 kVA scalable to 16 kVA N+1 Rack-mount, 208 V/240 V</b>	
<b>SYBT5 battery module</b>	
<p><b>Note:</b> The OSHPD-approved Symmetra LX Rack-mount models were seismic-tested in an APC NetShelter™ VX Seismic 42 U Enclosure (AR2145BLK).</p>	

# Facility Planning

## Specifications for Installations

### AC Input

Input Connections: Tower and Rack-Mount UPS			
Maximum Load	Method	Circuit Breaker Rating (Recommended)	Connection
8 kVA	Hardwired (Standard on tower and rack-mount)	50 A	<ul style="list-style-type: none"> <li>External circuit breaker</li> <li>#6 AWG (16mm<sup>2</sup>)</li> <li>Torque to 40 in-lb (4.5 N-m)</li> <li>4-Wire (L1-L2-N-G)*</li> </ul>
16 kVA	Hardwired (Standard on tower and rack-mount)	100 A	<ul style="list-style-type: none"> <li>External circuit breaker</li> <li>#3 AWG (25mm<sup>2</sup>)</li> <li>Torque to 40 in-lb (4.5 N-m)</li> <li>4-Wire (L1-L2-N-G)*</li> </ul>
* Wire connection “G” represents protective earth ground. 			

<b>Input Specifications: 208 V/240 V UPS</b>					
<b>Symmetra LX Model</b>	<b>16 kVA Extended Run Tower</b>	<b>16 kVA Tower</b>	<b>8 kVA Tower</b>	<b>16 kVA Rack-Mount</b>	<b>8 kVA Rack-Mount</b>
<b>SKU</b>	SYA16K16PXR	SYA16K16P	SYA8K8P	SYA16K16RMP	SYA8K8RMP
<b>Input Power (full load, Charging batteries)</b>	16.5 kW	16.5 kW	8.5 kW	16.5 kW	8.5 kW
<b>Input Power (full load, Batteries fully charged)</b>	14.9 kW	14.9 kW	7.5 kW	14.9 kW	7.5 kW
<b>Nominal Input Voltage</b>	208 Vac L-L (120 Vac L-N @ 120°) or 240 Vac L-L (120 Vac L-N @ 180°)				
<b>Input Voltage Range @ full load</b>	208 nom: 96 - 138 Vrms L-N, 166 - 244 Vrms L-L 240 nom: 83 - 138 Vrms L-N, 166 - 276 Vrms L-L Balanced, Grounded Neutral				
<b>Maximum Input Voltage</b>	150 Vac L-N				
<b>Normal Input Current on any phase (nominal mains, battery discharged)</b>	80 A	80 A	41 A	80 A	41 A
<b>Normal Input Current on any phase (nominal mains, battery charged)</b>	72 A	72 A	36 A	72 A	36 A
<b>Maximum Input Current on any phase (low mains, battery discharged)</b>	100 A	100 A	50 A	100 A	50 A
<b>Input overcurrent protection</b>	100 A resettable breaker	100 A resettable breaker	50 A resettable breaker	100 A resettable breaker	50 A resettable breaker
<b>Max Input leakage current</b>	5% input current rating				
<b>Input Power Factor</b>	0.90 at full load with 120/208 Vac source, 2PH + N + G, or 0.98 at full load with 120/240 Vac source, 2PH + N + G.				
<b>Input Power Factor Correction</b>	Yes				
<b>Input Frequency</b>	45 - 65 Hz				

## AC Output

Output Connections 208 V/240 V UPS			
Maximum Load	Method	Circuit Breaker Rating (Recommended)	Connection
8 kVA	Hardwired (Standard on tower and rack-mount)	50 A	<ul style="list-style-type: none"> <li>External circuit breaker</li> <li>#6 AWG (16mm<sup>2</sup>)</li> <li>Torque to 40 in-lb (4.5 N-m)</li> <li>4-Wire (L1-L2-N-G)*</li> </ul>
	Output receptacles (Standard on rack-mount)		<ul style="list-style-type: none"> <li>2 (L14-30R)</li> <li>4 (L5-20R)</li> </ul>
16 kVA	Hardwired (Standard on tower and rack-mount)	90 A	<ul style="list-style-type: none"> <li>External circuit breaker</li> <li>#3 AWG (25mm<sup>2</sup>)</li> <li>Torque to 40 in-lb (4.5 N-m)</li> <li>4-Wire (L1-L2-N-G)*</li> </ul>
	Output receptacles (Standard on rack-mount)		<ul style="list-style-type: none"> <li>4 (L14-30R)</li> <li>8 (L5-20R)</li> </ul>
* Wire connection "G" represents protective earth ground. 			

<b>Output Specifications: 208 V/240 V UPS</b>					
<b>Symmetra LX Model</b>	<b>16 kVA Extended Run Tower</b>	<b>16 kVA Tower</b>	<b>8 kVA Tower</b>	<b>16 kVA Rack-Mount</b>	<b>8 kVA Rack-Mount</b>
<b>SKU</b>	SYA16K16PXR	SYA16K16P	SYA8K8P	SYA16K16RMP	SYA8K8RMP
<b>Maximum Power, Watts</b>	12.8 kW, 6.4 kW per phase	12.8 kW, 6.4 kW per phase	6.4 kW, 3.2 kW per phase	12.8 kW, 6.4 kW per phase	6.4 kW, 3.2 kW per phase
<b>Maximum Power, VA</b>	16 kVA, 8 kVA per phase	16 kVA, 8 kVA per phase	8 kVA, 4 kVA per phase	16 kVA, 8 kVA per phase	8 kVA, 4 kVA per phase
<b>Output Power Overload (Watts or VA)</b>	<105% indefinitely; 130% indefinitely when configured for N+1; >105% for 4 seconds				
<b>Load Power Factor Range</b>	0.5 to 1.0				
<b>Nominal Output Voltages, Vac</b>	User-selectable 208 Vac L-L (120 Vac L-N @ 120°) or 240 Vac L-L (120 Vac L-N @ 180°)				
<b>Static Voltage Regulation</b>	±3% of nominal				
<b>Dynamic Load Response</b>	±5% of nominal and 60ms recovery time at step loads 0% to 100% or 100% to 0%.				
<b>Output current (A), RMS: Full Load – normal</b>	75	75	37	75	37
<b>Waveform</b>	Sinewave				
<b>Output Voltage THD, computer load</b>	Less than 5% at full load				
<b>Output Voltage THD, resistive load</b>	Less than 2% at full load				
<b>Load Crest Factor</b>	up to 5 : 1				
<b>Output Frequency On-Line (synchronized to mains if possible)</b>	50 +/-3.0 Hz and 60 +/- 3.0 Hz auto sense 60 +/- 0.1 Hz 50 +/- 0.1 Hz 60 +/- 3.0 Hz 50 +/- 3.0 Hz				
<b>Max Output Frequency Slew Rate</b>	5 Hz/second				
<b>Output Frequency on Battery</b>	50 or 60 Hz				
<b>Output Frequency in Bypass</b>	45 - 65 Hz (can be restricted to 47-53 or 57-63 Hz windows)				

# Configuration and Management

## Powerview User Interface

The Powerview user interface enables local monitoring, control, and configuration of a Symmetra LX UPS and Extended Run Cabinet.

See the *Symmetra LX Operations Guide* for an overview of operations and a detailed explanation of how to use the Powerview user interface.

To obtain the latest version of the documentation:

1. Go to **www.apc.com/site/products/index.cfm**.
2. Click on **Uninterruptible Power Supply (UPS)**
3. Under the **Network and Server** category, click on **Symmetra**.
4. On the Symmetra products page, click on a Symmetra LX model name.
5. Download the *Operations Guide* from the **Documentation** tab.

## Network Management Card 2

Symmetra LX models have the Network Management Card 2 with Environmental Monitoring pre-installed. This management card enables you to monitor and control an individual UPS remotely over your network.

See the *User's Guide, UPS Network Management Card 2, AP9630, AP9631* for information on how to use this management card. To obtain the latest version of this documentation:

1. Go to **www.apc.com/site/products/index.cfm**.
2. Click on **Uninterruptible Power Supply (UPS)**.
3. Under the **Network and Server** category, click on **Symmetra**.
4. On the Symmetra products page, click on a Symmetra LX model name.
5. Click on the **Software & Firmware** tab.
6. Under **Network Management Card**, find the listing for the latest **Network Management Card Firmware for Symmetra with AP9630/31**.
7. Click on the **Manuals** link in that listing.
8. Download the *User's Guide*.

## Remote Emergency Power Off (REPO)

All Symmetra LX models include a Remote Emergency Power Off (REPO) function.

- The output power can be disabled in an emergency by closing a switch connected to the REPO circuit, which shuts down the UPS and its load. You must manually reset the system enable switch on the front of the UPS to restart the unit.
- The REPO function can be initiated by an externally provided isolated dry contact (REPO).
- The REPO function is activated by the closure of a contact.

You can install the REPO switch in one of two ways:

- Use an external switch contact, and connect the REPO switch with the pre-installed jumper.
- Use a switch contact and a 24 V power supply external to the UPS. (Remove the jumper and connect the REPO switch.)



**Note:** In many locations, the Remote Emergency Power Off (REPO) switch must be installed by a licensed electrician. Refer to local and national codes.

To obtain the latest version of documentation pertaining to the REPO:

1. Go to **[www.apc.com/site/products/index.cfm](http://www.apc.com/site/products/index.cfm)**.
2. Click on **Uninterruptible Power Supply (UPS)**
3. Under the **Network and Server** category, click on **Symmetra**.
4. On the Symmetra products page, click on a Symmetra LX model name.
5. Download the following documentation from the **Documentation** tab:
  - a. See the *Symmetra LX Safety and General Information Guide* for REPO requirements and detailed safety instructions.
  - b. See the *Symmetra LX Electrical Installation* manual for complete installation instructions for the REPO.

# Physical

## Weights and Dimensions

SKU	UPS Cabinet	Weight, kg (lb)	Height, mm (in)	Width, mm (in)	Depth, mm (in)
SYA4K8P	4 kVA scalable to 8 kVA N+1 Tower	157.8 (347)	671 (26.42)	483 (19.00)	726 (28.60)
SYA4K8RMP	4 kVA scalable to 8 kVA N+1 Rack-mount	134.1 (295)	572 (22.50) (Rack Height 13 U)	472 (18.60)	688 (27.10)
SYA8K16P	8 kVA scalable to 16 kVA N+1, Tower	219.6 (483)	937 (36.90)	483 (19.00)	726 (28.60)
SYA8K16PXR	8 kVA scalable to 16 kVA N+1 Ext. Run Tower	473.6 (1042)	1516 (59.70)	483 (19.00)	726 (28.60)
SYA8K16RMP	8 kVA scalable to 16 kVA N+1 Rack-mount	198.6 (437)	836 (32.90) (Rack Height 19 U)	472 (18.60)	688 (27.10)
SYA8K8P	8 kVA scalable to 8 kVA N+1 Tower	201.8 (444)	671 (26.42)	483 (19.00)	726 (28.60)
SYA8K8RMP	8 kVA scalable to 8 kVA N+1 Rack-mount	178.2 (392)	572 (22.50) (Rack Height 13 U)	472 (18.60)	688 (27.10)
SYA12K16P	12 kVA scalable to 16 kVA N+1 Tower	263.6 (580)	937 (36.90)	483 (19.00)	726 (28.60)
SYA12K16PXR	12 kVA Scalable to 16 kVA N+1 Ext. Run Tower	488.6 (1075)	1516 (59.70)	483 (19.00)	726 (28.60)
SYA12K16RMP	12 kVA Scalable to 16 kVA N+1 Rack-mount	242.7 (534)	836 (32.90) (Rack Height 19 U)	472 (18.60)	688 (27.10)
SYA16K16P	16 kVA Scalable to 16 kVA N+1 Tower	307.7 (677)	937 (36.90)	483 (19.00)	726 (28.60)
SYA16K16PXR	16 kVA Scalable to 16 kVA N+1 Ext. Run Tower	503.6 (1108)	1516 (59.70)	483 (19.00)	726 (28.60)
SYA16K16RMP	16 kVA Scalable to 16 kVA N+1 Rack-mount	286.8 (631)	836 (32.90) (Rack Height 19 U)	472 (18.60)	688 (27.10)



## Shipping Weights and Dimensions

SKU	UPS Cabinet	Weight, kg (lb)	Height, mm (in)	Width, mm (in)	Depth, mm (in)
SYA4K8P	4 kVA scalable to 8 kVA N+1 Tower	179.1 (394)	914 (36.00)	599 (23.60)	997 (39.25)
SYA4K8RMP	4 kVA scalable to 8 kVA N+1 Rack-mount	166.3 (366)	787 (31.00)	599 (23.60)	997 (39.25)
SYA8K16P	8 kVA scalable to 16 kVA N+1, Tower	236.8 (521)	1181 (46.50)	599 (23.60)	997 (39.25)
SYA8K16PXR	8 kVA scalable to 16 kVA N+1 Ext. Run Tower	505.5 (1112)	1880 (74.00)	599 (23.60)	997 (39.26)
SYA8K16RMP	8 kVA scalable to 16 kVA N+1 Rack-mount	239.6 (527)	1054 (41.50)	599 (23.60)	997 (39.26)
SYA8K8P	8 kVA scalable to 8 kVA N+1 Tower	229.6 (505)	914 (36.00)	599 (23.60)	997 (39.26)
SYA8K8RMP	8 kVA scalable to 8 kVA N+1 Rack-mount	216.8 (477)	787 (31.00)	599 (23.60)	997 (39.25)
SYA12K16P	12 kVA scalable to 16 kVA N+1 Tower	287.2 (632)	1181 (46.50)	599 (23.60)	997 (39.25)
SYA12K16PXR	12 kVA Scalable to 16 kVA N+1 Ext. Run Tower	520.5 (1145)	1880 (74.00)	599 (23.60)	997 (39.26)
SYA12K16RMP	12 kVA Scalable to 16 kVA N+1 Rack-mount	290.0 (638)	1054 (41.50)	599 (23.60)	997 (39.26)
SYA16K16P	16 kVA Scalable to 16 kVA N+1 Tower	337.7 (743)	1181 (46.50)	599 (23.60)	997 (39.26)
SYA16K16PXR	16 kVA Scalable to 16 kVA N+1 Ext. Run Tower	535.5 (1178)	1880 (74.00)	599 (23.60)	997 (39.26)
SYA16K16RMP	16 kVA Scalable to 16 kVA N+1 Rack-mount	340.5 (749)	1054 (41.50)	599 (23.60)	997 (39.25)

# Environmental

## Requirements for Operation and Storage

Operating Environment	0 to 40 °C (32 to 104 °F)
Operating Relative Humidity	0 to 95%
Operating Elevation	0 to 3000 meters (0 to 10,000 feet)
Storage Temperature	-15 to 45 °C (5 to 113 °F)
Storage Relative Humidity	0 to 95%
Storage Elevation	0 to 4500 meters (0 to 15,000 feet)
Audible noise at 1 meter from surface of unit	62 dBA

## Heat Dissipation

Online Thermal Dissipation		
SKU	APC Symmetra Model	BTUs per hour
SYA4K8P	4 kVA scalable to 8 kVA N+1 Tower, 208/240 V	3485
SYA4K8RMP	4 kVA scalable to 8 kVA N+1 Rack-mount, 208/240 V	3707
SYA8K16P	8 kVA scalable to 16 kVA N+1, Tower 208/240 V	4995
SYA8K16PXR	8 kVA scalable to 16 kVA N+1 Ext. Run Tower, 208/240 V	4995
SYA8K16RMP	8 kVA scalable to 16 kVA N+1 Rack-mount, 208/240 V	4995
SYA8K8P	8 kVA scalable to 8 kVA N+1 Tower, 208/240 V	3485
SYA8K8RMP	8 kVA scalable to 8 kVA N+1 Rack-mount, 208/240 V	3707
SYA12K16P	12 kVA scalable to 16 kVA N+1 Tower, 208/240 V	4995
SYA12K16PXR	12 kVA scalable to 16 kVA N+1 Ext. Run Tower, 208/240 V	4995
SYA12K16RMP	12 kVA scalable to 16 kVA N+1 Rack-mount, 208/240 V	4995
SYA16K16P	16 kVA scalable to 16 kVA N+1 Tower, 208/240 V	4995
SYA16K16PXR	16 kVA scalable to 16 kVA N+1 Ext. Run Tower, 208/240 V	4995
SYA16K16RMP	16 kVA scalable to 16 kVA N+1 Rack-mount, 208/240 V	4995

# Drawings

In addition to the one drawing in this section for each model, other drawings are available on the Schneider Electric website:

- Mechanical drawings
- Single-line diagrams
- For tower models, illustrations for seismic anchoring

To view or download any of the additional drawings:

1. Go to <http://www.apc.com/site/products/index.cfm>.
2. Click on **Uninterruptible Power Supply (UPS)**.
3. Under the **Network and Server** category, click on Symmetra.
4. On the Symmetra products page, click on a Symmetra LX model name.
5. Click on the **Documentation** tab, and scroll downward.
6. Under **Submittal Drawings**, click on a drawing name to view or download it.

# SYA4K8P: Symmetra LX 4 kVA Scalable to 8 kVA N+1 Tower, 208/240 V

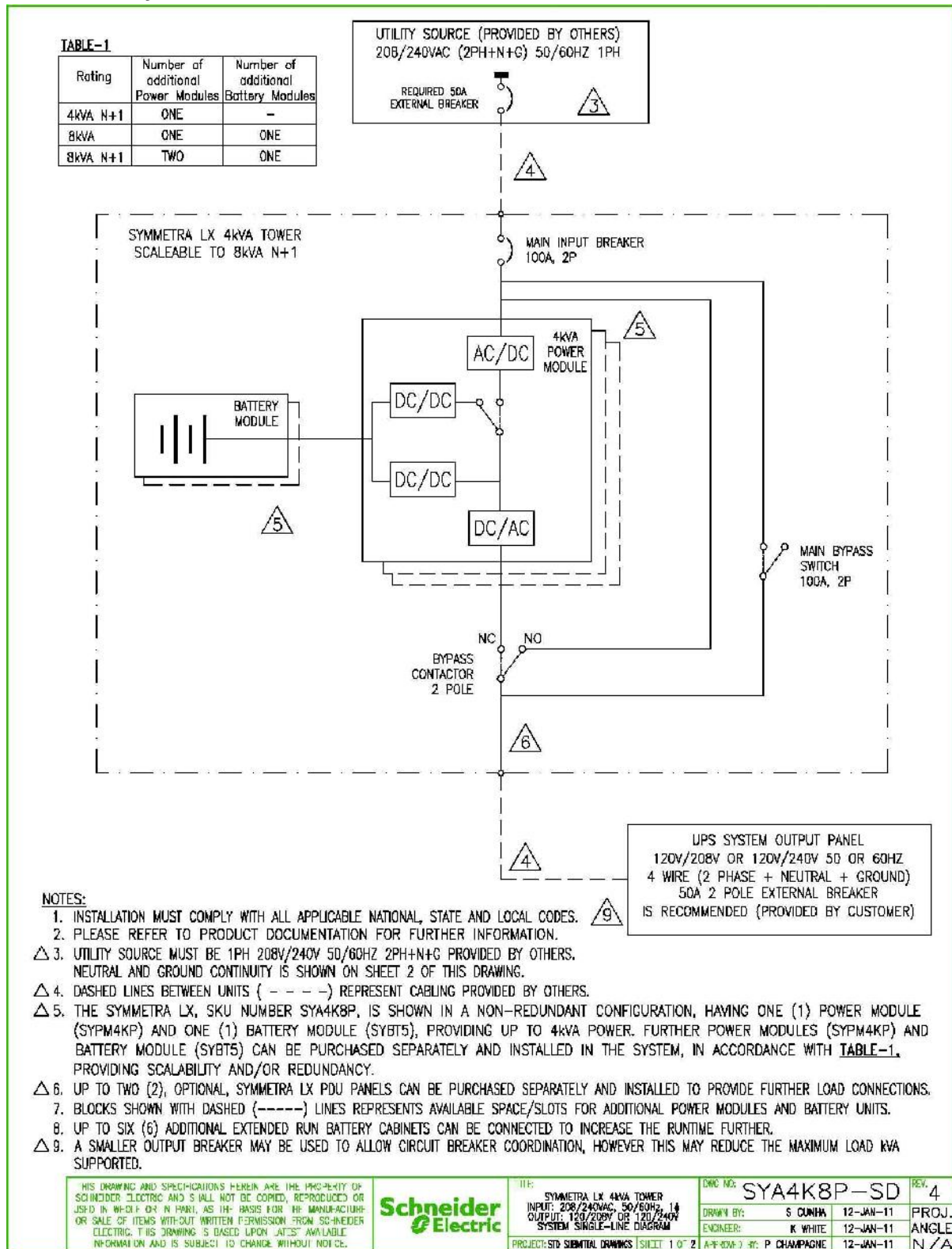

# SYA4K8RMP: Symmetra 4 kVA Scalable to 8 kVA N+1 Rack-Mount, 208/240 V

**TABLE-1**

Rating	Number of additional Power Modules	Number of additional Battery Modules
4kVA N+1	ONE	-
8kVA	ONE	ONE
8kVA N+1	TWO	ONE

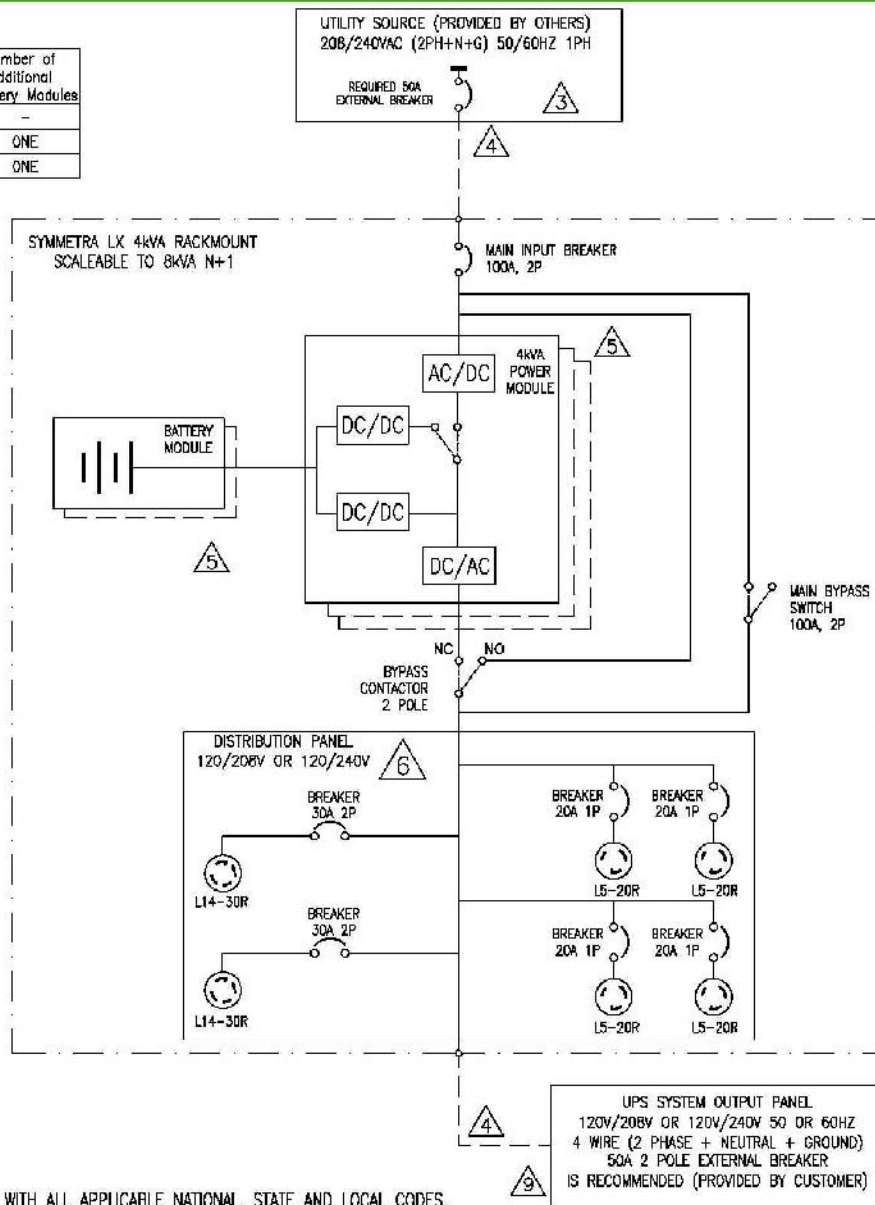

**NOTES:**

1. INSTALLATION MUST COMPLY WITH ALL APPLICABLE NATIONAL, STATE AND LOCAL CODES.
2. PLEASE REFER TO PRODUCT DOCUMENTATION FOR FURTHER INFORMATION.
- △ 3. UTILITY SOURCE MUST BE 1PH 208V/240V 50/60HZ 2PH+N+G PROVIDED BY OTHERS. NEUTRAL AND GROUND CONTINUITY IS SHOWN ON SHEET 2 OF THIS DRAWING.
- △ 4. DASHED LINES BETWEEN UNITS (---) REPRESENT CABLING PROVIDED BY OTHERS.
- △ 5. THE SYMMETRA LX, SKU NUMBER SYA4K8RMP, IS SHOWN IN A NON-REDUNDANT CONFIGURATION, HAVING ONE (1) POWER MODULE (SYPM4KP) AND ONE (1) BATTERY MODULE (SYBT5), PROVIDING UP TO 4KVA POWER. FURTHER POWER MODULES (SYPM4KP) AND BATTERY MODULE (SYBT5) CAN BE PURCHASED SEPARATELY AND INSTALLED IN THE SYSTEM, IN ACCORDANCE WITH TABLE-1, PROVIDING SCALABILITY AND/OR REDUNDANCY.
- △ 6. UP TO TWO (2), OPTIONAL, SYMMETRA LX PDU PANELS CAN BE PURCHASED SEPARATELY AND INSTALLED TO PROVIDE FURTHER LOAD CONNECTIONS.
7. BLOCKS SHOWN WITH DASHED (----) LINES REPRESENTS AVAILABLE SPACE/SLOTS FOR ADDITIONAL POWER MODULES AND BATTERY UNITS.
8. UP TO SIX (6) ADDITIONAL EXTENDED RUN BATTERY CABINETS CAN BE CONNECTED TO INCREASE THE RUNTIME FURTHER.
- △ 9. SMALLER OUTPUT BREAKER MAY BE USED TO ALLOW CIRCUIT BREAKER COORDINATION, HOWEVER THIS MAY REDUCE THE MAXIMUM LOAD KVA SUPPORTED.

THIS DRAWING AND SPECIFICATIONS HEREBY ARE THE PROPERTY OF SCHNEIDER ELECTRIC AND SHALL NOT BE COPIED, REPRODUCED OR USED IN WHOLE OR IN PART, AS THE BASIS FOR THE MANUFACTURE OR SALE OF ITEMS NOT-DIRECTLY DERIVED FROM SCHNEIDER ELECTRIC. THIS DRAWING IS BASED UPON LATEST AVAILABLE INFORMATION AND IS SUBJECT TO CHANGE WITHOUT NOTICE.



**TITLE**  
 SYMMETRA LX 4kVA RACKMOUNT  
 INPUT: 208/240VAC 50/60HZ 1φ  
 OUTPUT: 120/208V OR 120/240V  
 SYSTEM SINGLE-LINE DIAGRAM  
 PROJECT: SUBMITTAL DRAWINGS SHEET 1 OF 2

**DWG NO:** SYA4K8RMP-SD  
**REV:** 5  
 DRAWN: S CUNHA 12-JAN-11  
 PROJECT: PROJ. ANGLE  
 CHECKED: K WHITE 12-JAN-11  
 APPROVED: P CHAMPAGNE 12-JAN-11

# SYA8K16P: Symmetra 8 kVA Scalable to 16 kVA N+1, Tower, 208/240 V

TABLE-1

Rating	Number of Additional Power Module(s)	Number of Additional Battery Module(s)
8kVA N+1, Ext. run	ONE	—
12kVA, Ext. run	ONE	ONE
12kVA N+1, Ext. run	TWO	ONE
16kVA, Ext. run	TWO	TWO
16kVA N+1, Ext. run	THREE	TWO

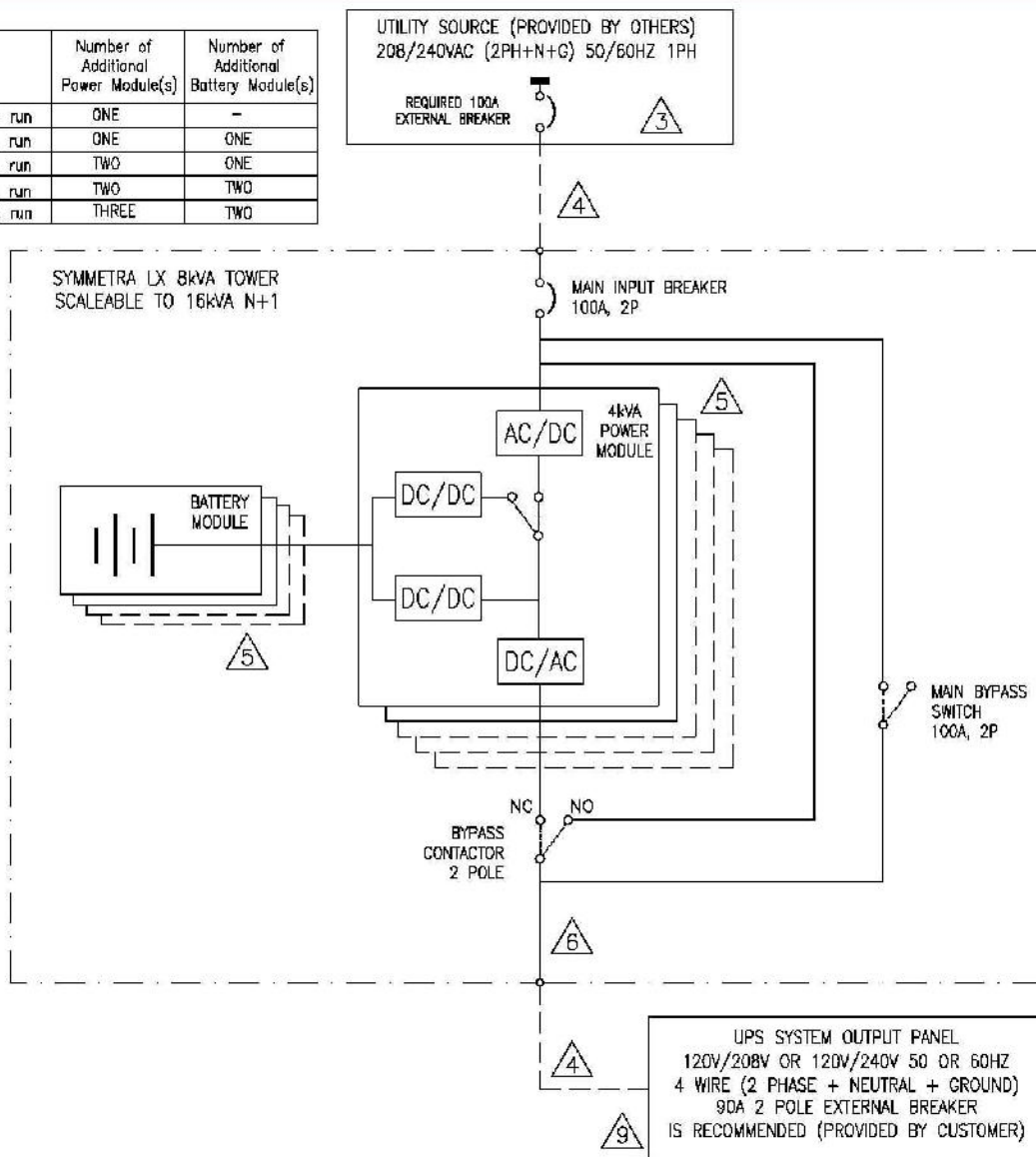

**NOTES:**

1. INSTALLATION MUST COMPLY WITH NATIONAL, STATE AND LOCAL CODES.
2. PLEASE REFER TO PRODUCT DOCUMENTATION FOR FURTHER INFORMATION.
- △ 3. UTILITY SOURCE MUST BE 1PH 208V/240V 50/60HZ 2PH+N+G PROVIDED BY OTHERS. NEUTRAL AND GROUND CONTINUITY IS SHOWN ON SHEET 2 OF THIS DRAWING.
- △ 4. DASHED LINES BETWEEN UNITS (---) REPRESENT CABLING PROVIDED BY OTHERS.
- △ 5. THE SYMMETRA LX, SKU NUMBER SYA8K16P, IS SHOWN IN A NON-REDUNDANT CONFIGURATION, HAVING TWO (2) POWER MODULES (SYPM4KP) AND TWO (2) BATTERY MODULES (SYBT5), PROVIDING UP TO 8kVA POWER. FURTHER POWER MODULES (SYPM4KP) AND BATTERY MODULES (SYBT5) CAN BE PURCHASED SEPARATELY AND INSTALLED IN THE SYSTEM, IN ACCORDANCE WITH TABLE-1, PROVIDING SCALABILITY AND/OR REDUNDANCY.
- △ 6. UP TO FOUR (4), OPTIONAL, SYMMETRA LX PDU PANELS CAN BE PURCHASED SEPARATELY AND INSTALLED TO PROVIDE FURTHER LOAD CONNECTIONS.
7. BLOCKS SHOWN WITH DASHED (-----) LINES REPRESENTS AVAILABLE SPACE/SLOTS FOR ADDITIONAL POWER MODULES AND BATTERY UNITS.
8. UP TO SIX (6) ADDITIONAL EXTENDED RUN BATTERY CABINETS CAN BE CONNECTED TO INCREASE THE RUNTIME FURTHER.
- △ 9. A SMALLER OUTPUT BREAKER MAY BE USED TO ALLOW CIRCUIT BREAKER COORDINATION, HOWEVER THIS MAY REDUCE THE MAXIMUM LOAD KVA SUPPORTED.

THIS DRAWING AND SPECIFICATIONS HEREBY ARE THE PROPERTY OF SCHNEIDER ELECTRIC AND SHALL NOT BE COPIED, REPRODUCED OR USED IN WHOLE OR IN PART, AS THE BASIS FOR THE MANUFACTURE OR SALE OF ITEMS WITHOUT WRITTEN PERMISSION FROM SCHNEIDER ELECTRIC. THIS DRAWING IS BASED UPON LATEST AVAILABLE INFORMATION AND IS SUBJECT TO CHANGE WITHOUT NOTICE.



TITLE: SYMMETRA LX 8kVA TOWER  
 INPUT: 208/240VAC, 50/60Hz, 1φ  
 OUTPUT: 120/208V OR 120/240V  
 SYSTEM SINGLE-LINE DIAGRAM

DWG NO: SYA8K16P-SD REV: 3  
 DRAWN BY: S CUNHA 12-JAN-11 PROJ.  
 ENGINEER: K WHITE 12-JAN-11 ANGLE  
 APPROVED BY: P CHAMPAGNE 12-JAN-11 N/A



# SYA8K16PXR: Symmetra 8 kVA Scalable to 16 kVA N+1 Ext. Run Tower, 208/240 V

TABLE-1

Rating	Number of additional Power Modules
8kVA N+1, Ext. Run	ONE
12kVA Ext. Run	ONE
12kVA N+1, Ext. Run	TWO
16kVA Ext. Run	TWO
16kVA N+1, Ext. Run	THREE

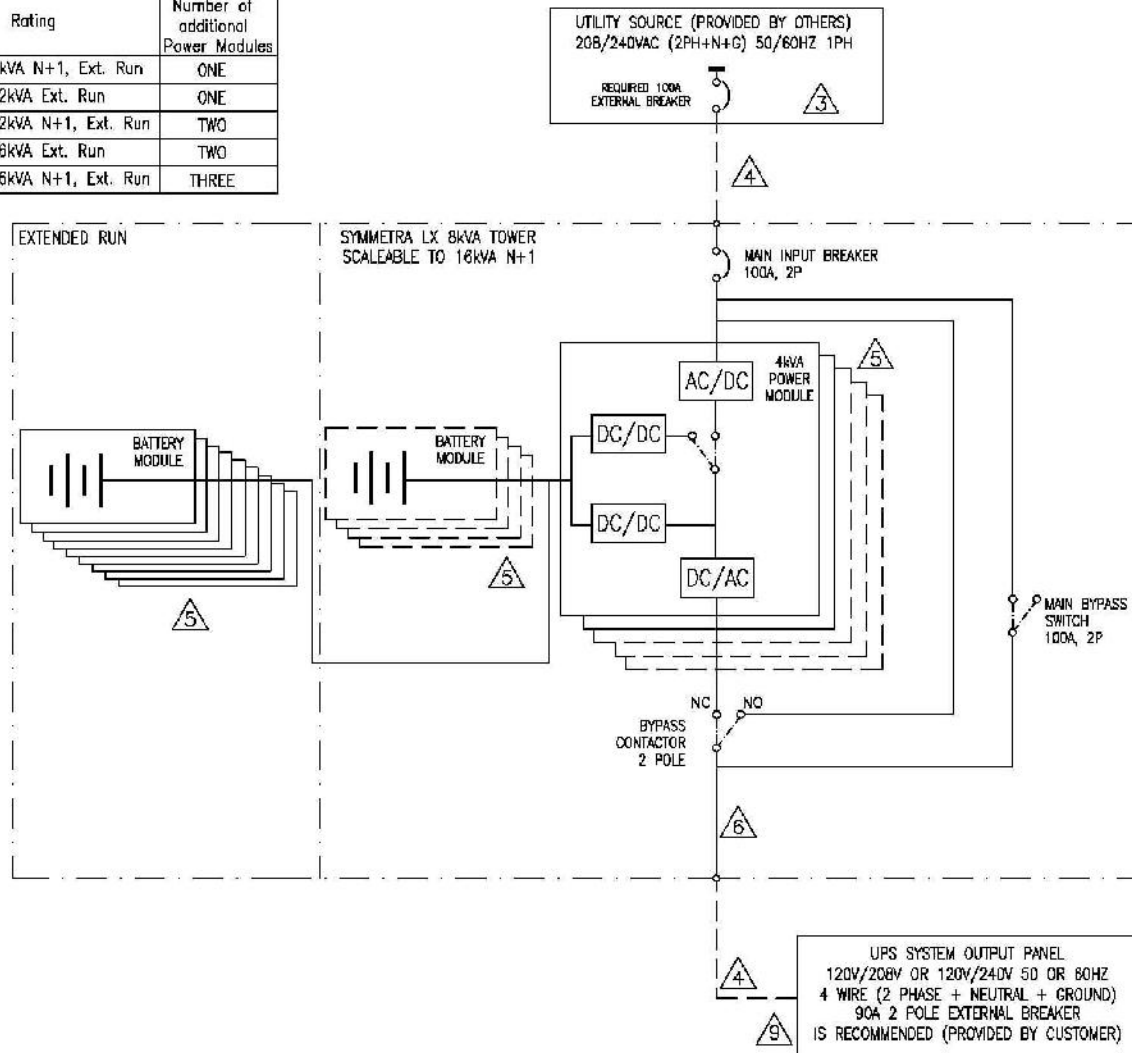

**NOTES:**

1. INSTALLATION MUST COMPLY WITH ALL APPLICABLE NATIONAL, STATE AND LOCAL CODES.
2. PLEASE REFER TO PRODUCT DOCUMENTATION FOR FURTHER INFORMATION.
- Δ3. UTILITY SOURCE MUST BE 1PH 208V/240V 50/60HZ 2PH+N+G PROVIDED BY OTHERS. NEUTRAL AND GROUND CONTINUITY IS SHOWN ON SHEET 2 OF THIS DRAWING.
- Δ4. DASHED LINES BETWEEN UNITS ( - - - - ) REPRESENT CABLING PROVIDED BY OTHERS.
- Δ5. THE SYMMETRA LX SKU NUMBER SYA8K16PXR, IS SHOWN IN A NON-REDUNDANT CONFIGURATION, HAVING TWO (2) POWER MODULES (SYPM4KP) AND NINE (9) BATTERY MODULES (SYBT5), PROVIDING UP TO 8KVA POWER. FURTHER POWER MODULES (SYPM4KP) CAN BE PURCHASED SEPARATELY AND INSTALLED IN THE SYSTEM, IN ACCORDANCE WITH TABLE-1, PROVIDING SALABILITY AND/OR REDUNDANCY. THE RUNTIME CAN ALSO BE FURTHER EXTENDED BY THE PURCHASE AND INSTALLATION OF UP TO FOUR (4) ADDITIONAL BATTERY MODULES (SYBT5) IN THE MAIN UPS FRAME.
- Δ6. UP TO THREE (3), OPTIONAL, SYMMETRA LX PDU PANELS CAN BE PURCHASED SEPARATELY AND INSTALLED TO PROVIDE FURTHER LOAD CONNECTIONS.
7. BLOCKS SHOWN WITH DASHED (-----) LINES REPRESENTS AVAILABLE SPACE/SLOTS FOR ADDITIONAL POWER MODULES AND BATTERY UNITS.
8. UP TO SIX (6) ADDITIONAL EXTENDED RUN BATTERY CABINETS CAN BE CONNECTED TO INCREASE THE RUNTIME FURTHER.
- Δ9. A SMALLER OUTPUT BREAKER MAY BE USED TO ALLOW CIRCUIT BREAKER COORDINATION, HOWEVER THIS MAY REDUCE THE MAXIMUM LOAD KVA SUPPORTED.

THIS DRAWING AND SPECIFICATIONS HEREBY ARE THE PROPERTY OF SCHNEIDER ELECTRIC AND SHALL NOT BE COPIED, REPRODUCED OR USED IN WHOLE OR IN PART, AS THE BASIS FOR THE MANUFACTURE OR SALE OF ITEMS WITHOUT WRITTEN PERMISSION FROM SCHNEIDER ELECTRIC. THIS DRAWING IS BASED UPON LATEST AVAILABLE INFORMATION AND IS SUBJECT TO CHANGE WITHOUT NOTICE.



TITLE: SYMMETRA LX 8KVA TOWER, XR INPUT: 208/240VAC, 50/60HZ, 1Φ OUTPUT: 120/208V OR 120/240V SYSTEM SINGLE-LINE DIAGRAM

DWG NO: SYA8K16PXR-SD REV: 3  
 DRAWN BY: S DUNHA 12-JAN-11 PROJ.  
 ENGINEER: K WHITE 12-JAN-11 ANGLE  
 APPROVED BY: P CHAMPAGNE 12-JAN-11 N/A

# SYA8K16RMP: Symmetra 8 kVA Scalable to 16 kVA N+1 Rack-Mount, 208/240 V

**TABLE-1**

Rating	Number of Additional Power Module(s)	Number of Additional Battery Module(s)
8kVA N+1, Ext. run	ONE	-
12kVA, Ext. run	ONE	ONE
12kVA N+1, Ext. run	TWO	ONE
16kVA, Ext. run	TWO	TWO
16kVA N+1, Ext. run	THREE	TWO

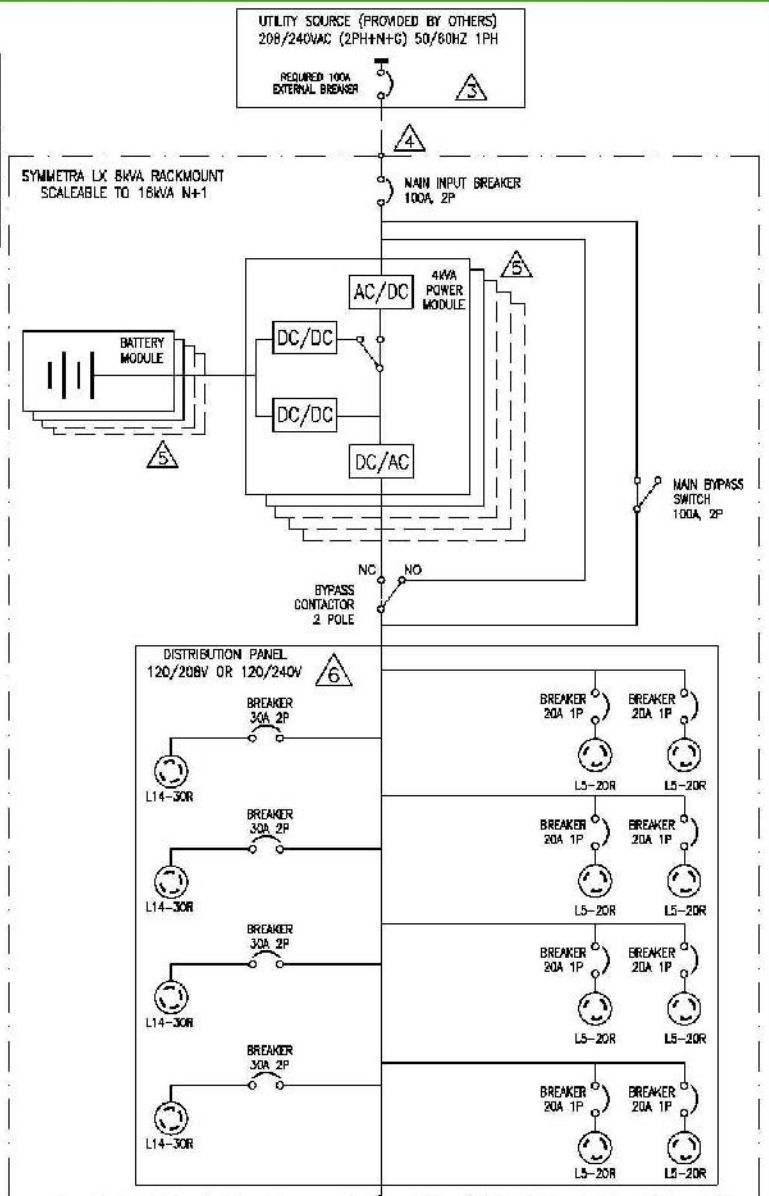

**NOTES:**

1. INSTALLATION MUST COMPLY WITH NATIONAL, STATE AND LOCAL CODES.
2. PLEASE REFER TO PRODUCT DOCUMENTATION FOR FURTHER INFORMATION.
- △ 3. UTILITY SOURCE MUST BE 1PH 208V/240V 50/60HZ 2PH+N+G PROVIDED BY OTHERS. NEUTRAL AND GROUND CONTINUITY IS SHOWN ON SHEET 2 OF THIS DRAWING.
- △ 4. DASHED LINES BETWEEN UNITS ( - - - - ) REPRESENT CABLING PROVIDED BY OTHERS.
- △ 5. THE SYMMETRA LX, SKU NUMBER SYA8K16RMP, IS SHOWN IN A NON-REDUNDANT CONFIGURATION, HAVING TWO (2) POWER MODULES (SYPM4KP) AND TWO (2) BATTERY MODULES (SYBT5), PROVIDING UP TO 8kVA POWER. FURTHER POWER MODULES (SYPM4KP) AND BATTERY MODULES (SYBT5) CAN BE PURCHASED SEPARATELY AND INSTALLED IN THE SYSTEM, IN ACCORDANCE WITH TABLE-1, PROVIDING SCALABILITY AND/OR REDUNDANCY.
- △ 6. UP TO FOUR (4), OPTIONAL, SYMMETRA LX PDU PANELS CAN BE PURCHASED SEPARATELY AND INSTALLED TO PROVIDE FURTHER LOAD CONNECTIONS.
7. BLOCKS SHOWN WITH DASHED (-----) LINES REPRESENTS AVAILABLE SPACE/SLOTS FOR ADDITIONAL POWER MODULES AND BATTERY UNITS.
8. UP TO SIX (6) ADDITIONAL EXTENDED RUN BATTERY CABINETS CAN BE CONNECTED TO INCREASE THE RUNTIME FURTHER.
- △ 9. SMALLER OUTPUT BREAKER MAY BE USED TO ALLOW CIRCUIT BREAKER COORDINATION, HOWEVER THIS MAY REDUCE THE MAXIMUM LOAD kVA SUPPORTED.

THIS DRAWING AND SPECIFICATIONS HEREBY ARE THE PROPERTY OF SCHNEIDER ELECTRIC AND SHALL NOT BE COPIED, REPRODUCED OR USED IN WHOLE OR IN PART, AS THE BASIS FOR THE MANUFACTURE OR SALE OF ITEMS WITHOUT WRITTEN PERMISSION FROM SCHNEIDER ELECTRIC. THIS DRAWING IS BASED UPON LATEST AVAILABLE INFORMATION AND IS SUBJECT TO CHANGE WITHOUT NOTICE.



**TITLE**  
SYMMETRA LX 8kVA RACKMOUNT  
INPUT: 208/240VAC 50/60HZ 1φ  
OUTPUT: 120/208V OR 120/240V  
SYSTEM SINGLE-LINE DIAGRAM

**DWG NO:** SYA8K16RMP-SD **REV:** 4  
**DRAWN:** S CUNHA 12-JAN-11 **PROJ:** ANGLE  
**ENGINEER:** K WHITE 12-JAN-11  
**APPROVED:** P CHAMPAGNE 12-JAN-11 **N/A**



## SYA8K8P: Symmetra 8 kVA Scalable to 8 kVA N+1 Tower, 208/240 V

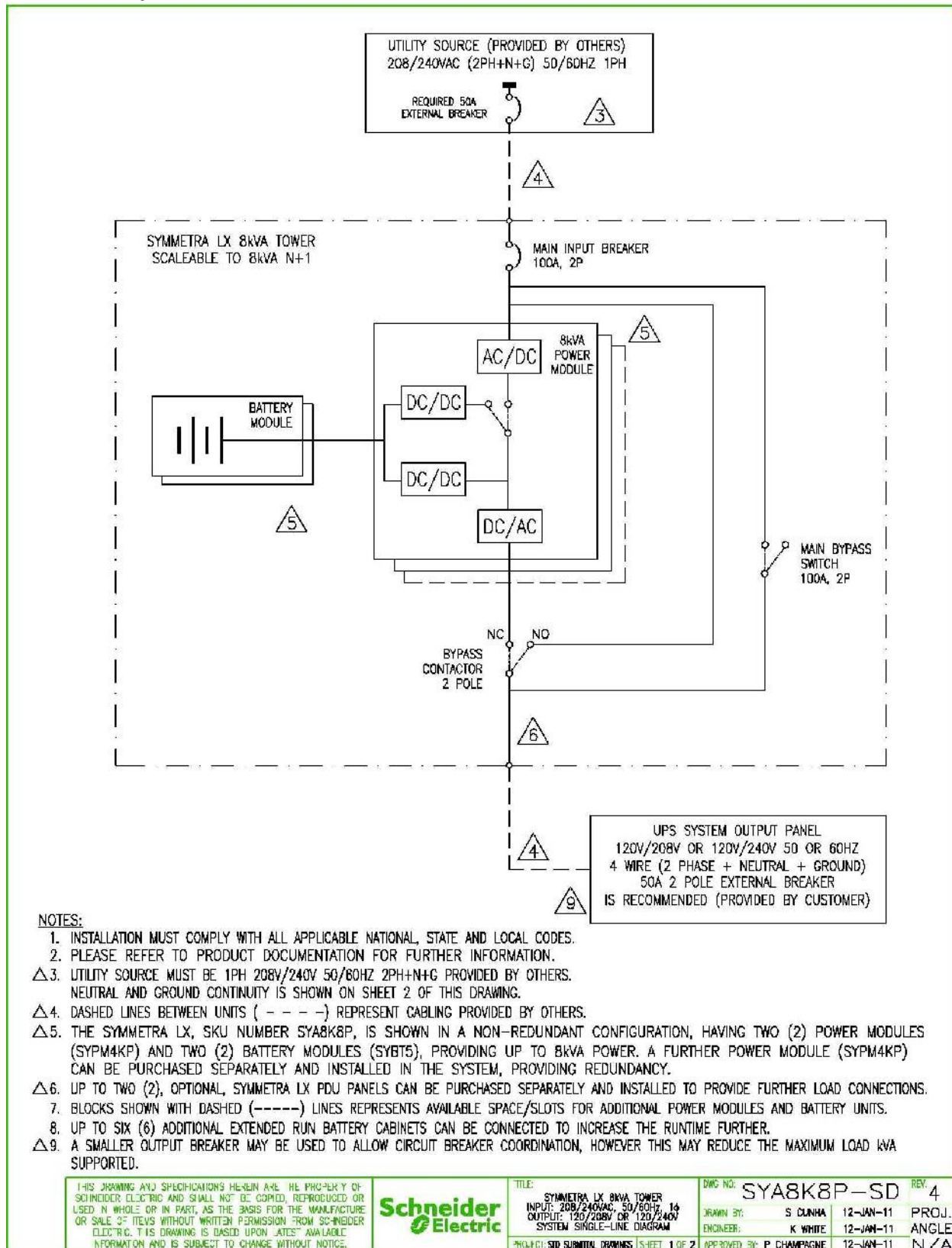

# SYA8K8RMP: Symmetra 8 kVA Scalable to 8 kVA N+1 Rack-Mount, 208/240 V

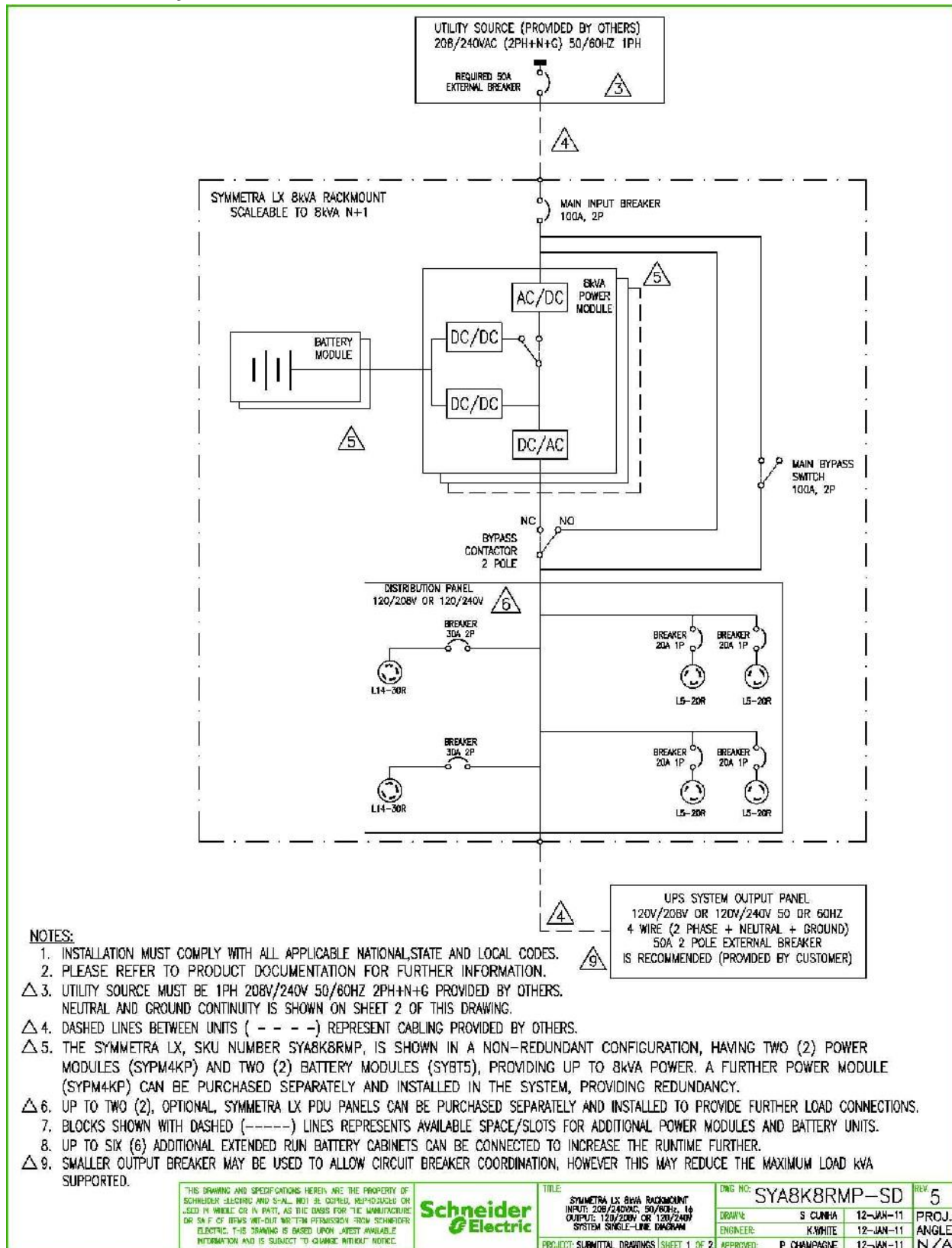

# SYA12K16P: Symmetra 12 kVA Scalable to 16 kVA N+1 Tower, 208/240 V

TABLE-1

Rating	Number of Additional Power Module(s)	Number of Additional Battery Module(s)
12kVA N+1, Ext. run	ONE	-
16kVA, Ext. run	ONE	DNE
18kVA N+1, Ext. run	TWO	DNE

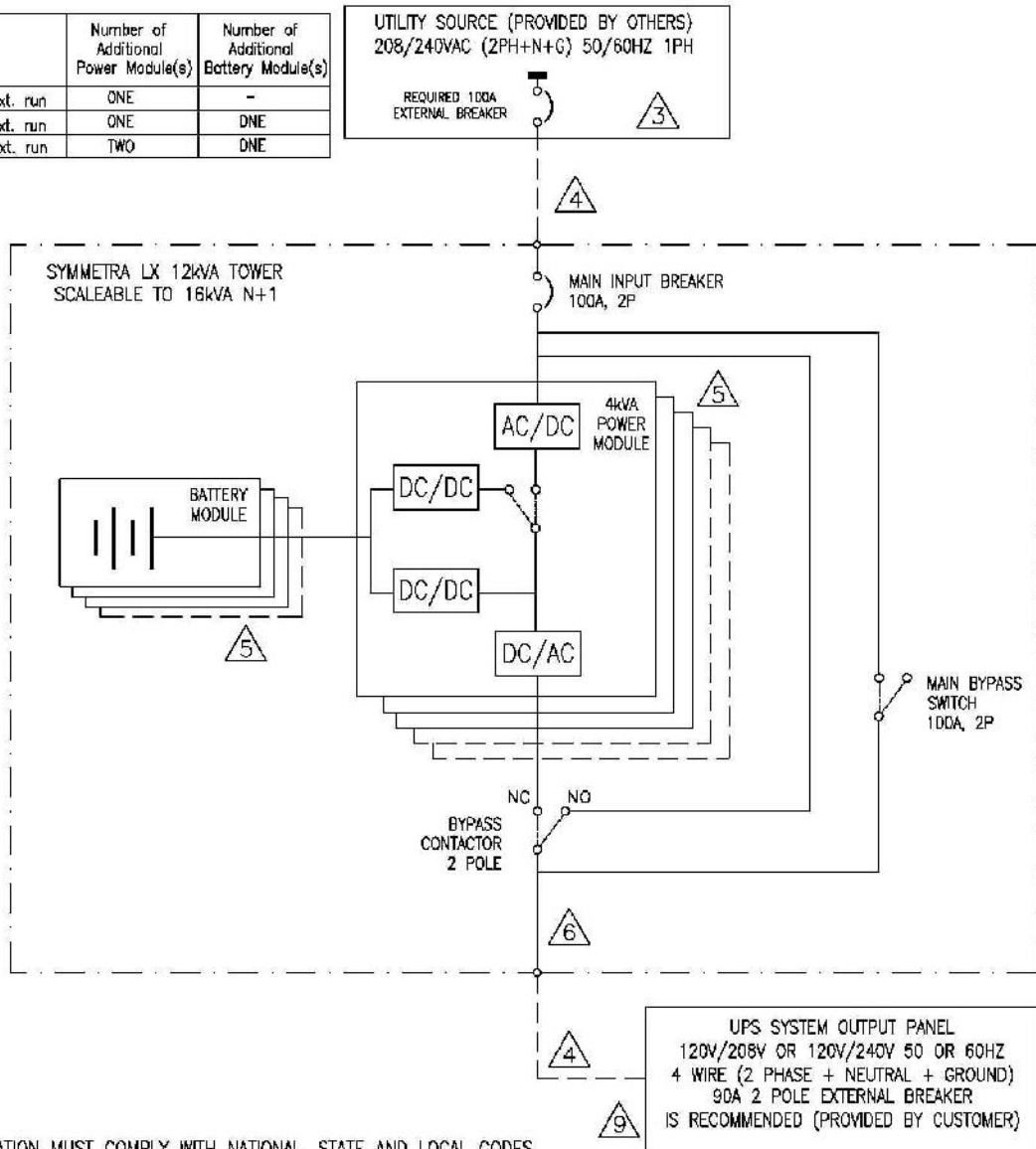

**NOTES:**

1. INSTALLATION MUST COMPLY WITH NATIONAL, STATE AND LOCAL CODES.
2. PLEASE REFER TO PRODUCT DOCUMENTATION FOR FURTHER INFORMATION.
- △3. UTILITY SOURCE MUST BE 1PH 208V/240V 50/60HZ 2PH+N+G PROVIDED BY OTHERS. NEUTRAL AND GROUND CONTINUITY IS SHOWN ON SHEET 2 OF THIS DRAWING.
- △4. DASHED LINES BETWEEN UNITS ( - - - - ) REPRESENT CABLING PROVIDED BY OTHERS.
- △5. THE SYMMETRA LX, SKU NUMBER SYA12K16P, IS SHOWN IN A NON-REDUNDANT CONFIGURATION, HAVING THREE (3) POWER MODULES (SYPM4KP) AND THREE (3) BATTERY MODULES (SYBT5). PROVIDING UP TO 12kVA POWER. FURTHER POWER MODULES (SYPM4KP) AND BATTERY MODULE (SYBT5) CAN BE PURCHASED SEPARATELY AND INSTALLED IN THE SYSTEM, IN ACCORDANCE WITH TABLE-1, PROVIDING SCALABILITY AND/OR REDUNDANCY.
- △6. UP TO FOUR (4), OPTIONAL, SYMMETRA LX PDU PANELS CAN BE PURCHASED SEPARATELY AND INSTALLED TO PROVIDE FURTHER LOAD CONNECTIONS.
7. BLOCKS SHOWN WITH DASHED (-----) LINES REPRESENTS AVAILABLE SPACE/SLOTS FOR ADDITIONAL POWER MODULES AND BATTERY UNITS.
8. UP TO SIX (6) ADDITIONAL EXTENDED RUN BATTERY CABINETS CAN BE CONNECTED TO INCREASE THE RUNTIME FURTHER.
- △9. A SMALLER OUTPUT BREAKER MAY BE USED TO ALLOW CIRCUIT BREAKER COORDINATION, HOWEVER THIS MAY REDUCE THE MAXIMUM LOAD KVA SUPPORTED.

THIS DRAWING AND SPECIFICATIONS HEREBY ARE THE PROPERTY OF SCHNEIDER ELECTRIC AND SHALL NOT BE COPIED, REPRODUCED OR USED IN WHOLE OR IN PART, AS THE BASIS FOR THE MANUFACTURE OR SALE OF ITEMS WITHOUT WRITTEN PERMISSION FROM SCHNEIDER ELECTRIC. THIS DRAWING IS BASED UPON LATEST AVAILABLE INFORMATION AND IS SUBJECT TO CHANGE WITHOUT NOTICE.



TITLE: SYMMETRA LX 12kVA TOWER  
 INPUT: 208/240VAC 50/60HZ 1φ  
 OUTPUT: 120/208V OR 120/240V  
 SYSTEM SINGLE-LINE DIAGRAM  
 PROJECT: SD SUBMITTAL DRAWINGS SHEET 1 OF 2

DWG NO: SYA12K16P-SD REV: 3  
 DRAWN BY: S DUNHA 12-JAN-11 PROJ.  
 ENGINEER: K WHITE 12-JAN-11 ANGLE  
 APPROVED BY: P CHAMPAGNE 12-JAN-11 N/A



# SYA12K16PXR: Symmetra 12 kVA Scalable to 16 kVA N+1 Ext. Run Tower, 208/240 V

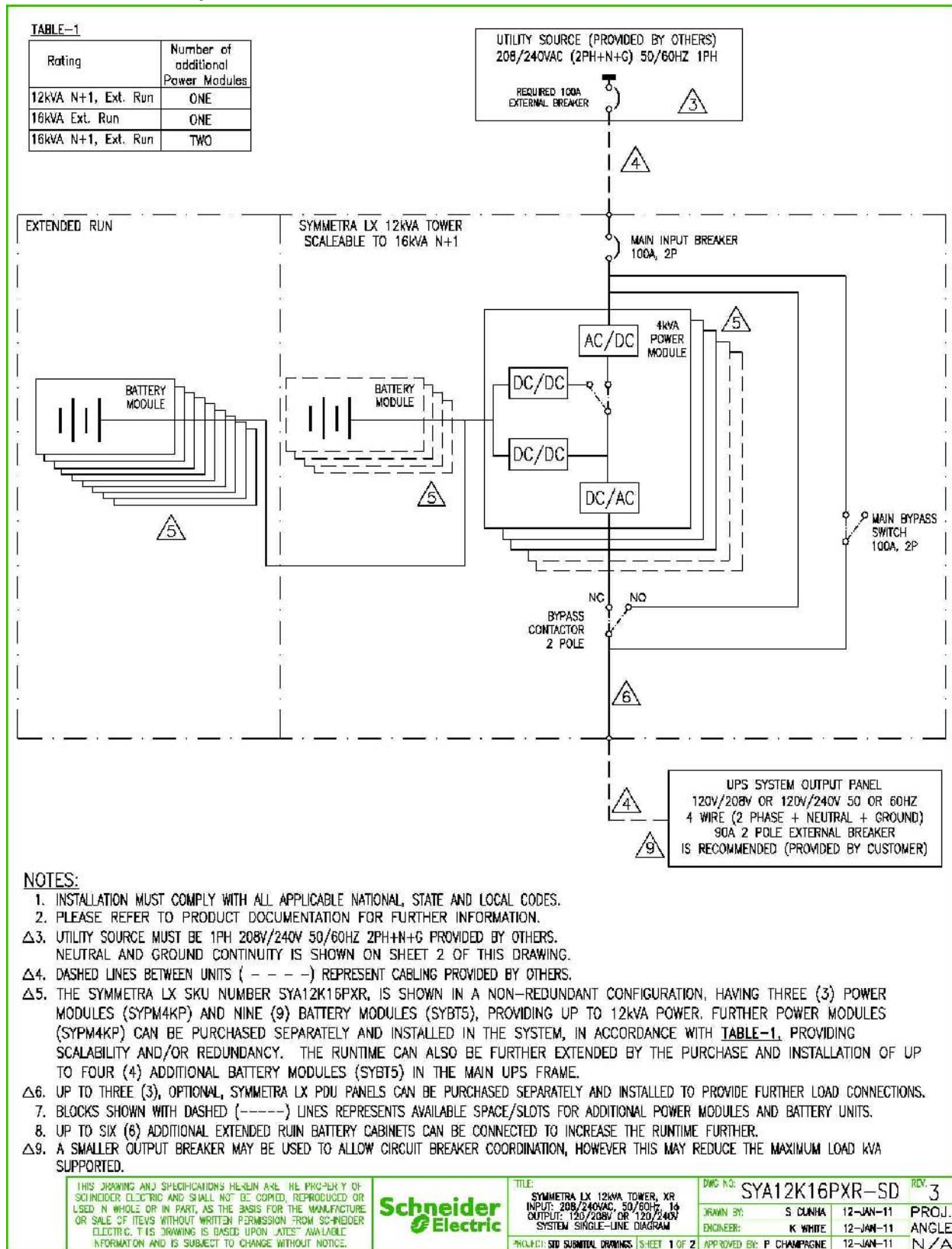

# SYA12K16RMP: Symmetra 12 kVA Scalable to 16 kVA N+1 Rack-Mount, 208/240 V

**TABLE-1**

Rating	Number of Additional Power Module(s)	Number of Additional Battery Module(s)
12kVA N+1, Ext. run	ONE	—
16kVA Ext. run	ONE	ONE
16kVA N+1, Ext. run	TWO	ONE

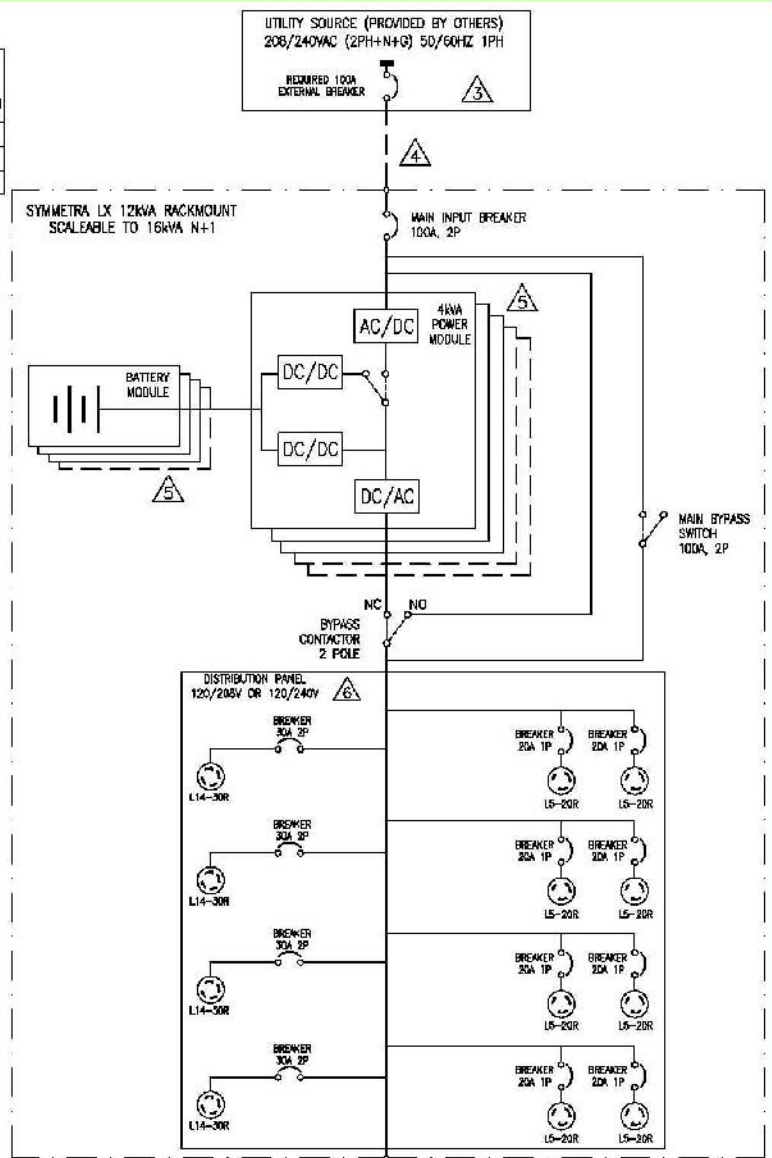

**NOTES:**

1. INSTALLATION MUST COMPLY WITH NATIONAL, STATE AND LOCAL CODES.
2. PLEASE REFER TO PRODUCT DOCUMENTATION FOR FURTHER INFORMATION.
- △ 3. UTILITY SOURCE MUST BE 1PH 208V/240V 50/60HZ 2PH+N+G PROVIDED BY OTHERS. NEUTRAL AND GROUND CONTINUITY IS SHOWN ON SHEET 2 OF THIS DRAWING.
- △ 4. DASHED LINES BETWEEN UNITS ( - - - - ) REPRESENT CABLING PROVIDED BY OTHERS.
- △ 5. THE SYMMETRA LX, SKU NUMBER SYA12K16RMP, IS SHOWN IN A NON-REDUNDANT CONFIGURATION, HAVING THREE (3) POWER MODULES (SYPM4KP) AND THREE (3) BATTERY MODULES (SYBT5), PROVIDING UP TO 12KVA POWER. FURTHER POWER MODULES (SYPM4KP) AND BATTERY MODULE (SYBT5) CAN BE PURCHASED SEPARATELY AND INSTALLED IN THE SYSTEM, IN ACCORDANCE WITH **TABLE-1**, PROVIDING SCALABILITY AND/OR REDUNDANCY.
- △ 6. UP TO FOUR (4), OPTIONAL, SYMMETRA LX PDU PANELS CAN BE PURCHASED SEPARATELY AND INSTALLED TO PROVIDE FURTHER LOAD CONNECTIONS.
7. BLOCKS SHOWN WITH DASHED (-----) LINES REPRESENTS AVAILABLE SPACE/SLOTS FOR ADDITIONAL POWER MODULES AND BATTERY UNITS.
8. UP TO SIX (6) ADDITIONAL EXTENDED RUN BATTERY CABINETS CAN BE CONNECTED TO INCREASE THE RUNTIME FURTHER.
- △ 9. SMALLER OUTPUT BREAKER MAY BE USED TO ALLOW CIRCUIT BREAKER COORDINATION, HOWEVER THIS MAY REDUCE THE MAXIMUM LOAD KVA SUPPORTED.

THIS DRAWING AND SPECIFICATIONS HERIN ARE THE PROPERTY OF SCHNEIDER ELECTRIC AND SHALL NOT BE COPIED, REPRODUCED OR USED IN WHOLE OR IN PART, AS THE BASIS FOR THE MANUFACTURE OR SALE OF ITEMS WITHOUT WRITTEN PERMISSION FROM SCHNEIDER ELECTRIC. THIS DRAWING IS BASED UPON LATEST AVAILABLE INFORMATION AND IS SUBJECT TO CHANGE WITHOUT NOTICE.



**TITLE**  
SYMMETRA LX 12KVA RACKMOUNT  
INPUT: 208/240VAC, 50/60HZ, 1φ  
OUTPUT: 120/208V OR 120/240V  
SYSTEM SINGLE-LINE DIAGRAM  
PROJECT: SUBMITTAL DRAWINGS SHEET 1 OF 2

**DWG NO:** SYA12K16RMP-SD  
**REV:** 4  
**DRWN:** S CUNHA 12-JAN-11  
**ENGR:** K WHITE 12-JAN-11  
**APPR:** P CHAMPAGNE 12-JAN-11  
**PROJ:** ANGLE  
**REV:** N/A

# SYA16K16P: Symmetra 16 kVA Scalable to 16 kVA N+1 Tower, 208/240 V

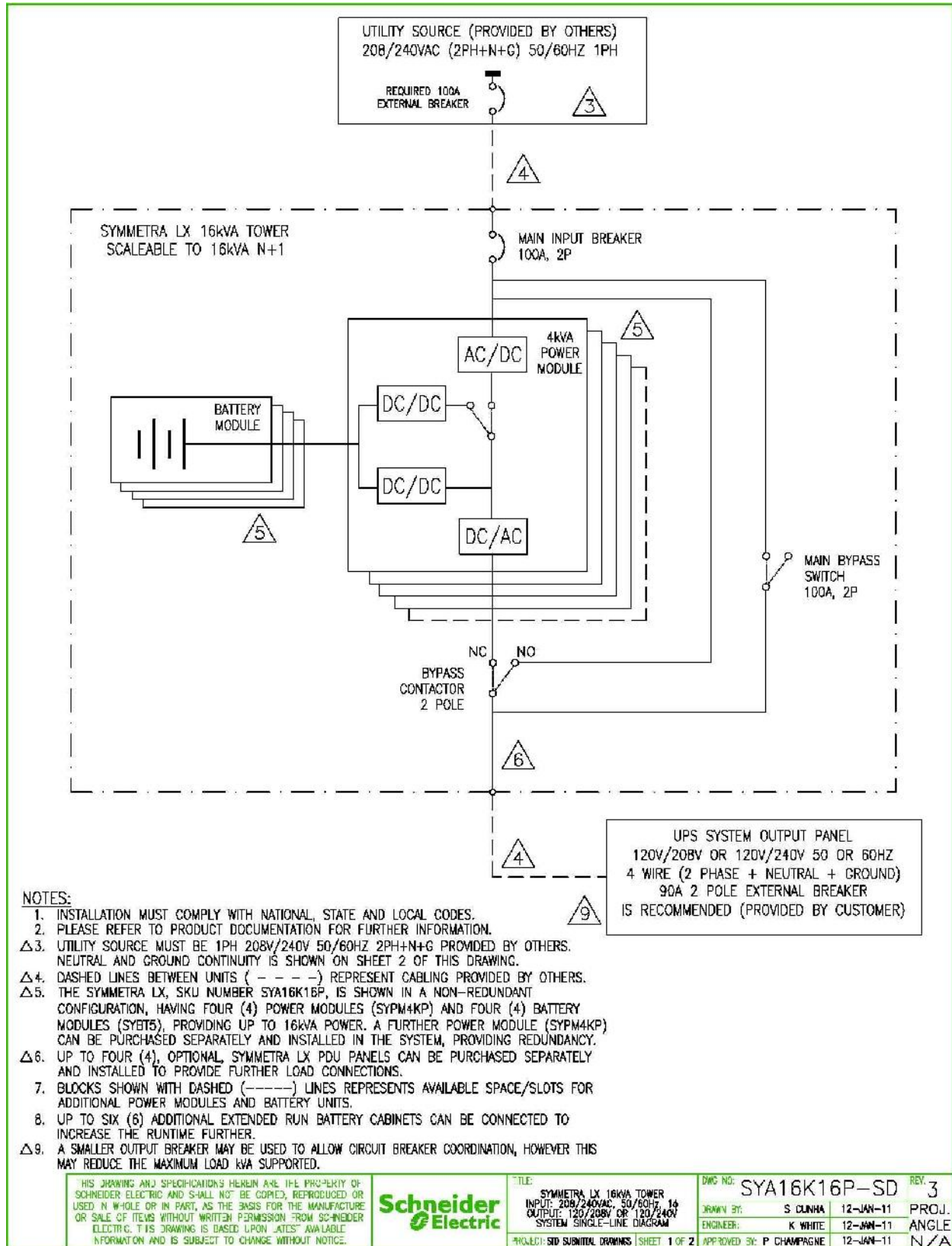



# SYA16K16PXR: Symmetra 16 kVA Scalable to 16 kVA N+1 Ext. Run Tower, 208/240 V

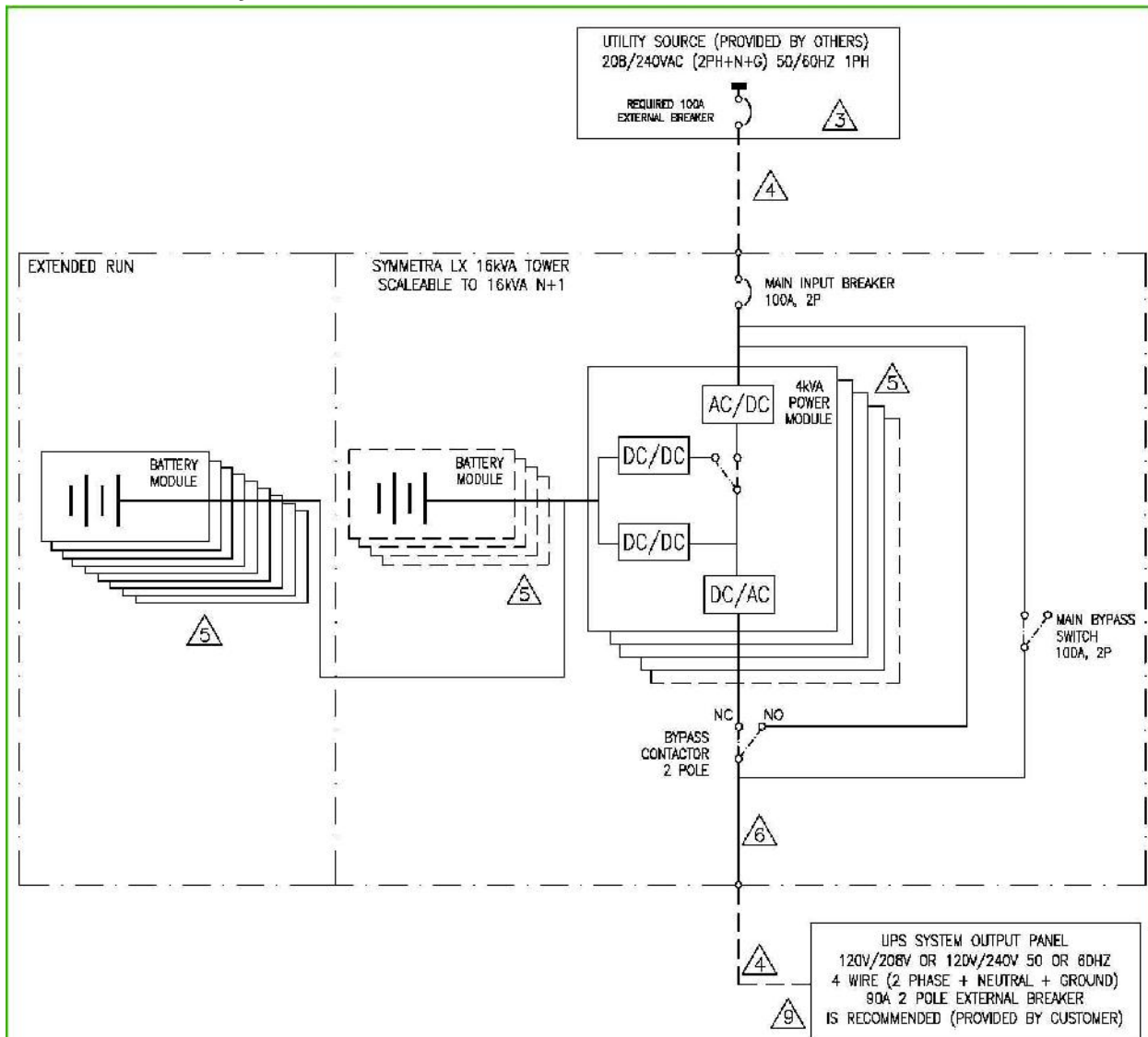

## NOTES:

1. INSTALLATION MUST COMPLY WITH ALL APPLICABLE NATIONAL, STATE AND LOCAL CODES.
2. PLEASE REFER TO PRODUCT DOCUMENTATION FOR FURTHER INFORMATION.
- △3. UTILITY SOURCE MUST BE 1PH 208V/240V 50/60HZ 2PH+N+G PROVIDED BY OTHERS. NEUTRAL AND GROUND CONTINUITY IS SHOWN ON SHEET 2 OF THIS DRAWING.
- △4. DASHED LINES BETWEEN UNITS ( - - - - ) REPRESENT CABLING PROVIDED BY OTHERS.
- △5. THE SYMMETRA LX SKU NUMBER SYA16K16PXR, IS SHOWN IN A NON-REDUNDANT CONFIGURATION, HAVING FOUR (4) POWER MODULES (SYPM4KP) AND NINE (9) BATTERY MODULES (SYBT5), PROVIDING UP TO 16kVA POWER. FURTHER POWER MODULE (SYPM4KP) CAN BE PURCHASED SEPARATELY AND INSTALLED IN THE SYSTEM TO PROVIDE AN N+1 REDUNDANT SYSTEM, OFFERING A TOTAL SYSTEM POWER OF UP TO 16kVA WITH REDUNDANCY. THE RUNTIME CAN ALSO BE FURTHER EXTENDED BY THE PURCHASE AND INSTALLATION OF UP TO FOUR (4) ADDITIONAL BATTERY MODULES (SYBT5) IN THE MAIN UPS FRAME.
- △6. UP TO THREE (3), OPTIONAL, SYMMETRA LX PDU PANELS CAN BE PURCHASED SEPARATELY AND INSTALLED TO PROVIDE FURTHER LOAD CONNECTIONS.
7. BLOCKS SHOWN WITH DASHED (-----) LINES REPRESENTS AVAILABLE SPACE/SLOTS FOR ADDITIONAL POWER MODULES AND BATTERY UNITS.
8. UP TO SIX (6) ADDITIONAL EXTENDED RUN BATTERY CABINETS CAN BE CONNECTED TO INCREASE THE RUNTIME FURTHER.
- △9. SMALLER OUTPUT BREAKER MAY BE USED TO ALLOW CIRCUIT BREAKER COORDINATION, HOWEVER THIS MAY REDUCE THE MAXIMUM LOAD KVA SUPPORTED.

THIS DRAWING AND SPECIFICATIONS HEREBY ARE THE PROPERTY OF SCHNEIDER ELECTRIC AND SHALL NOT BE COPIED, REPRODUCED OR USED IN WHOLE OR IN PART, AS THE BASIS FOR THE MANUFACTURE OR SALE OF ITEMS WITHOUT WRITTEN PERMISSION FROM SCHNEIDER ELECTRIC. THIS DRAWING IS BASED UPON LATEST AVAILABLE INFORMATION AND IS SUBJECT TO CHANGE WITHOUT NOTICE.

**Schneider Electric**

TITLE:  
SYMMETRA LX 16kVA TOWER, XR  
INPUT: 208/240VAC, 50/60HZ, 1PH  
OUTPUT: 120/208V OR 120/240V  
SYSTEM SINGLE-LINE DIAGRAM

DWG NO: SYA16K16PXR-SD REV: 3  
DRAWN BY: S DUNHA 12-JAN-11 PROJ.  
ENGINEER: K WHITE 12-JAN-11 ANGLE  
APPROVED BY: P CHAMFRAGNE 12-JAN-11 N/A

# SYA16K16RMP: Symmetra 16 kVA Scalable to 16 kVA N+1 Rack-Mount, 208/240 V

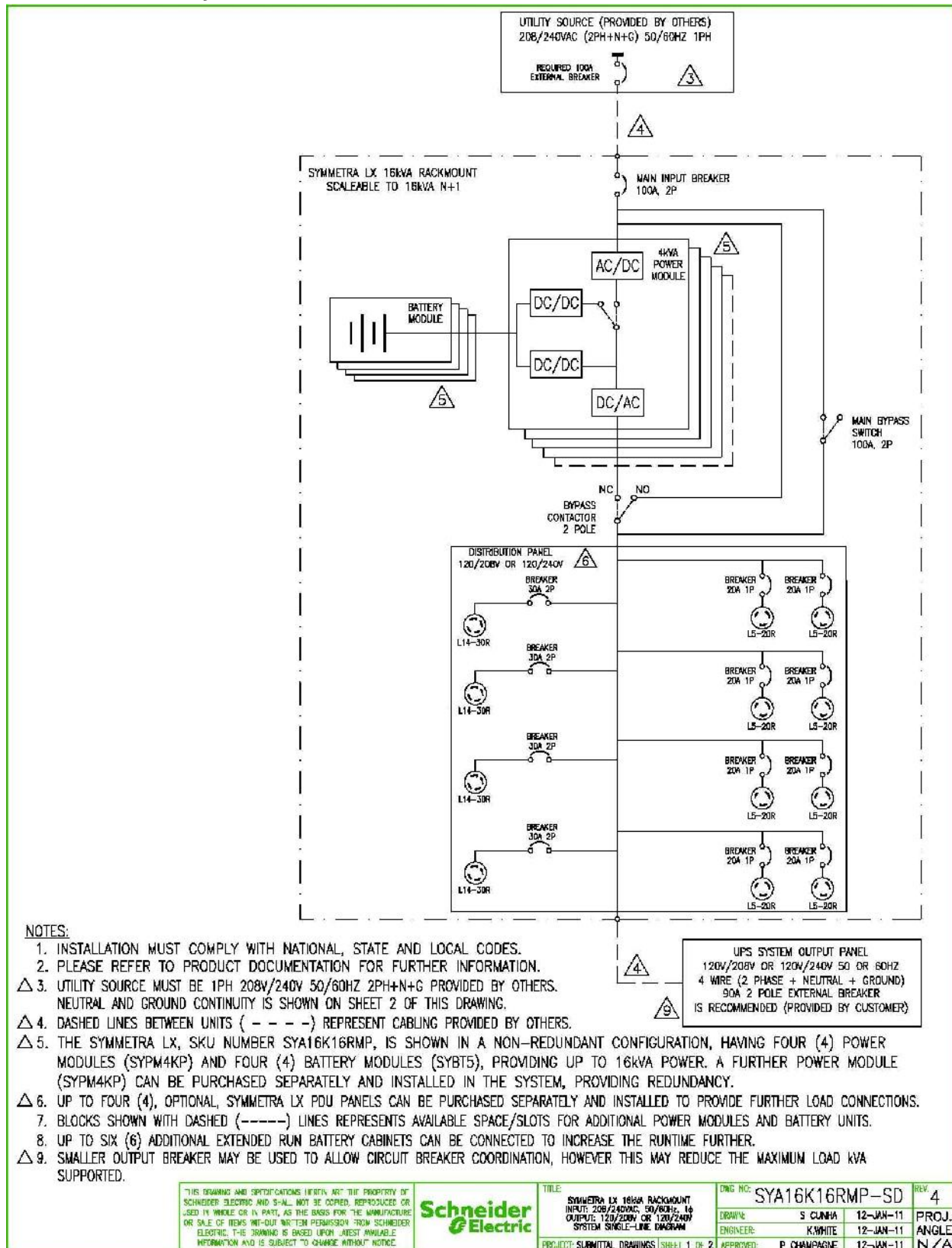



# Options

---

## Hardware Options

### Symmetra Battery Systems

APC Symmetra LX Extended Run Rack-mount with 3 SYBT5, 208 V	SYARMXR3B3
APC Symmetra LX Extended Run Rack-mount with 9 SYBT5, 208 V	SYARMXR9B9
APC Symmetra LX Extended Run Tower with 9 SYBT5, 208 V	SYAXR9B9
APC Symmetra 3 Battery Rack-mount XR Frame (208 V/120 V Regions)	SYBFXR3RM
APC Symmetra LX 9 Battery Tower XR Frame, 208 V	SYBFXR9
APC Symmetra LX 9 Battery Rack-mount XR Frame, 208 V	SYBFXR9RM
APC Symmetra LX Battery Module	SYBT5
APC Symmetra LX Battery Module with flame-retardant case	SYBT5FR

### Symmetra Battery Cables

APC Symmetra LX 15-foot battery cabinet cable – 200 V/208 V	SYAOPT5
APC Symmetra RM and LX 4 ft. extender battery cable for 200 V/208 V/240 V RM and LX XR battery cabinets	SYOPT4

### Interface Cables

UPS Communications Cable Simple-Signaling	940-0020
UPS Communication Cable Smart-Signaling	940-0024
UPS Communications Cable Smart-Signaling 4.5 m/15 ft	AP9804
5 m /15 ft Extension Cable for use with UPS communications cable	AP9815
UNIX Basic Signaling Cable	AP9823
Isolate Serial Extension Cable	AP9825

### UPS Network Management Cards

UPS Network Management Card with Environmental Monitoring and Out-of-Band Management	AP9618
UPS Network Management Card 2	AP9630
UPS Network Management Card 2 with Environmental Monitoring	AP9631

### Additional Management Cards and Options

SmartSlot Expansion Chassis	AP9600
SmartSlot Triple Chassis Black	AP9604BLK
Relay I/O SmartSlot Card for dry contact management	AP9610
Out-of-Band Management SmartSlot Card	AP9608

### Rack-Mounting Hardware

Symmetra LX module CTO kit - UPS Frame	SYAOPT2
Symmetra LX module CTO kit - XR3 Frame	SYAOPT2XR3

Symmetra LX module CTO kit - XR9 Frame	SYAOPT2XR9
Symmetra LX Four-Post Rack-Mounting Rails	SYAOPT1
Symmetra LX/Symmetra RM Two-Post Rail Kit	SYOPT12
<b>Maintenance Bypass Panels</b>	
APC Service Bypass Panel – 200 V/208 V/240 V; 100 A; MBB; Hardwire input/output	SBP16KP
APC Service Bypass Panel - 200 V/208 V/240 V; 100 A; MBB; Hardwire input; (6) L14-30R output	SBP16KRMP4U
APC Service Bypass Panel 200 V/208 V/240 V Symmetra LX 4-16 kVA; (1) L14-30R, (3) L5-20R, (1) 100 A Hardwire	SBP16KRMP4U-HW
<b>Isolation Transformers</b>	
APC WW 10 kVA Isolation Transformer	APTF10KW01
APC WW 20 kVA Isolation Transformer	APTF20KW01
<b>Power Distribution Units</b>	
Rack PDU, Basic, Zero U, 20 A, 120 V, (24) 5-20	AP7530
Rack PDU, Basic, Zero U, 20 A, 120 V, (14) 5-15	AP9551
Rack PDU, Basic, 1 U, 20 A, 120 V, (10) 5-20; L5-20P	AP9564
Rack PDU Extender, Basic, 2 U, 30 A, 200 V/208 V/240 V, (4) L5-20	AP7580
Rack PDU Extender, Basic, 2 U, 30 A, 200 V/208 V/240 V, (4) L5-30	AP7583
Rack PDU Extender, Basic, 2 U, 30 A, 200 V/208 V, (4) L6-20	AP7581
Rack PDU Extender, Basic, 2 U, 30 A, 120 V, (12) 5-20	AP7582
Rack PDU Extender, Basic, 2 U, 30 A, 200 V/208 V, (4) L6-30	AP7584
Rack PDU, Metered, 1 U, 20 A, 120 V, (8) 5-20	AP7801
Rack PDU, Metered, Zero U, 20 A, 120 V, (24) NEMA 5-20R	AP7830
Rack PDU, Switched, 1 U, 20 A, 120 V, (8) 5-20	AP7901
Rack PDU, Switched, Zero U, 20 A, 120 V, (24) 5-20	AP7930
<b>Backplates and Panels</b>	
Symmetra RM and LX 208 V/240 V Backplate Kit with (2) L6-30R	SYPD11
Symmetra PDU Airflow Management Blanking Panel	SYPD2
Symmetra RM and LX 208 V/240 V Backplate Kit with (3) L6-20R	SYPD7
Symmetra LX Power Distribution Panel; (1) L14-30, (2) L5-20	SYAPD1
Symmetra RM and LX 208 V/240 V Backplate Kit with (2) L6-20R and (1) L6-30R	SYPD3
<b>Power Modules for N+1 Redundancy</b>	
Symmetra LX 4 kVA Power Module, 200 V/208 V	SYPM4KP
<b>Parts and Accessories</b>	
Symmetra LX frame electronics module – 200 V/208 V	SYAFSU13

Symmetra LX Input/Output wiring tray – 200 V/208 V	SYAFSU14
Symmetra LX Communications Card	SYAFSU15
Symmetra LX 13 U replacement door	SYAFSU2
Symmetra LX 19 U replacement door	SYAFSU3
Symmetra LX 32 U replacement door	SYAFSU5
Symmetra LX Castor kit - left front, right rear	SYAFSU6
Symmetra LX Castor kit - right front, left rear	SYAFSU7
Symmetra LX top panel	SYAFSU8
Symmetra LX 13 U left side panel	SYAFSU9L
Symmetra LX 19 U left side panel	SYAFSU10L
Symmetra LX 32 U left side panel	SYAFSU12L
Symmetra LX 13 U right side panel	SYAFSU9R
Symmetra LX 19 U right side panel	SYAFSU10R
Symmetra LX 32 U right side panel	SYAFSU12R

## Software Options

StruxureWare™ Central Basic	AP9465
StruxureWare Central Standard	AP9470
StruxureWare Central Enterprise	AP9475
StruxureWare Central Standard Management Pack	AP9480
StruxureWare Central Basic Management Pack	AP9482
StruxureWare Central Enterprise Management Pack	AP9485



Note: All Symmetra LX Rack-Mount models are certified for use with StruxureWare management software.

# Limited Warranty

---

American Power Conversion (APC) warrants its products to be free from defects in materials and workmanship for a period of two years from the date of purchase, except in India where the period is one year for battery module(s). Its obligation under this warranty is limited to repairing or replacing, at its own sole option, any such defective products. To obtain service under warranty you must obtain a Returned Material Authorization (RMA) number from customer support (see Service in the *Symmetra LX Operations Manual*). Products must be returned with transportation charges prepaid and must be accompanied by a brief description of the problem encountered and proof of date and place of purchase. This warranty does not apply to equipment that has been damaged by accident, negligence, or misapplication or has been altered or modified in any way. This warranty applies only to the original purchaser who must have properly registered the product within 10 days of purchase.

**EXCEPT AS PROVIDED HEREIN, AMERICAN POWER CONVERSION MAKES NO WARRANTIES, EXPRESSED OR IMPLIED, INCLUDING WARRANTIES OF MERCHANTABILITY AND FITNESS FOR A PARTICULAR PURPOSE.** Some states do not permit limitation or exclusion of implied warranties; therefore, the aforesaid limitation(s) or exclusion(s) may not apply to the purchaser.

**EXCEPT AS PROVIDED ABOVE, IN NO EVENT WILL APC BE LIABLE FOR DIRECT, INDIRECT, SPECIAL, INCIDENTAL, OR CONSEQUENTIAL DAMAGES ARISING OUT OF THE USE OF THIS PRODUCT, EVEN IF ADVISED OF THE POSSIBILITY OF SUCH DAMAGE.** Specifically, APC is not liable for any costs, such as lost profits or revenue, loss of equipment, loss of use of equipment, loss of software, loss of data, costs of substitutes, claims by third parties, or otherwise. This warranty gives you specific legal rights and you may have other rights that vary from state to state.

# Worldwide Customer Support

Customer support is available at no charge via e-mail or telephone. Contact information is available at [www.apc.com/support/contact](http://www.apc.com/support/contact).

© APC by Schneider Electric. APC and the APC logo are owned by Schneider Electric Industries S.A.S., American Power Conversion Corporation, or their affiliated companies. All other trademarks are property of their respective owners.